

Di Lusso

R6/R6 Slimline



Wood Burning Inset Stove Installation and Operating Instructions

CVSDL06-FP3BLK/CVSDL06-FP3PWTD/CVSDL06-FP4BLK/CVSDL06-FP4PWTD
CVSDS06-FP3BLK/CVSDS06-FP3PWTD/CVSDS06-FP4BLK/CVSDS06-FP4PWTD

JINDLU06/06S REV F 13092017

Di Lusso

CONTENTS INDEX:

WARRANTY.....	2
TECHNICAL SPECIFICATION.....	3
GENERAL GUIDANCE.....	4
SAFETY.....	4/5
INSTALLATION	
APPLIANCE DIMENSIONS.....	6
FLUE REQUIREMENTS.....	7
DI LUSSO R6/R6 SLIMLINE INSTALLATION.....	8 - 10
FITTING THE STOVE – BOTH.....	11
DI LUSSO R6/R6 SLIMLINE FLUE CONNECTION.....	11/12
DI LUSSO R6 ENCLOSURE INSTALLATION.....	12/13
RE-ASSEMBLING THE STOVE.....	14/15
OPERATING INSTRUCTIONS.....	15 - 18
MAINTENANCE.....	18/19
TROUBLESHOOTING.....	19
SPARES.....	20 - 22
INSTALLATION AND COMMISSIONING CHECK LIST.....	23
SERVICE RECORDS.....	24
FULL WARRANTY INFORMATION.....	25/26



HUNTER STOVES GROUP,
8 Emperor Way,
Exeter Business Park,
Exeter,
Devon. EX1 3QS

Email: info@hunterstoves.co.uk
Website: <http://www.hunterstoves.co.uk>

WARRANTY

HUNTER STOVES GROUP OFFER A STANDARD 2-YEAR WARRANTY IF PURCHASED THROUGH A RECOGNISED DEALER. 1-YEAR STATUTORY APPLIES IF PURCHASED THROUGH AN INTERNET COMPANY. WE ALSO OFFER AN EXTENDED 10-YEAR WARRANTY ON NON-CONSUMABLE PARTS. PLEASE SEE THE WARRANTY SECTION AT WWW.HUNTERSTOVES.CO.UK OR ON PAGES 25/26 OF THESE INSTRUCTIONS FOR FURTHER INFORMATION.

THE WARRANTY WILL ONLY BE VALID IF THE APPLIANCE IS INSTALLED BY AN APPROPRIATELY QUALIFIED ENGINEER IN ACCORDANCE WITH THE MANUFACTURER'S INSTRUCTIONS AND TO THE APPROPRIATE BUILDING REGULATIONS AND/OR LOCAL BY-LAWS AND SERVICED WITHIN 12 MONTHS OF INSTALLATION.

THIS APPLIANCE MUST BE REGULARLY SERVICED AND MAINTAINED, USING ONLY HUNTER STOVES GROUP APPROVED COMPONENTS FOR THE WARRANTY TO BE VALID.

Technical Specification

 hunterstoves GROUP Di LUSO CE		R6 Di Lusso	Slimline R6 Di Lusso	
Energy Efficiency Class		A	A	
Nominal Heat Output	Wood	4,9kW	4,9kW	
Energy Efficiency		101	101	
Efficiency	Wood	76%	76%	
Mean CO (@13% O ₂)	Wood	0.20%	0.20%	
Appliance Mass		116kg	116kg	
Recommended Fuels	Wood	Seasoned Wood (less than 20% moisture content)		
Log Length		330mm	330mm	
FLUES	Mean Flue Gas Temperature	Wood	269°C	269°C
	Flue Gas Mass Flow	Wood	5.8 g/s	5.8 g/s
	Flue Outlet Size (Top or Rear Option)		127mm	127mm
VENTILATION	- Where leakage is greater than 5m ³ /hour/m ² - Ventilation normally required = 550mm ² per kW output over 5kW		NONE	NONE
	- Where leakage is less than or equal to 5m ³ /hour/m ² - Ventilation normally required = 550mm ² per kW output		2695mm ²	2695mm ²
<u>Minimum Clearance to Combustible Material</u>				
At the sides of the stove		400mm (from outside of frame)	40mm (from outside of frame)	
In front of the stove (to furniture etc.)		1200mm	1200mm	

This appliance is not suitable for use in a shared flue

This appliance is suitable for intermittent burning

Smoke Control Areas

This appliance is only exempt for use in a smoke control area when fitted with a smoke control area kit (JDLU0501). Find out if you are in a Smoke Control Area by contacting your Local Authority

General Guidance

It is important that your stove is correctly installed and operated as Hunter Stoves Group cannot accept responsibility for any fault arising through incorrect installation, use, maintenance or servicing.

These instructions cover the basic principles to ensure satisfactory installation of the stove, although detail may need slight modification to suit local site conditions.

The installation must comply with current Building Regulations, National and European Standards, Local Authority Byelaws and other specifications or regulations as they affect the installation of the appliance.

The Building Regulations requirements may also be met by adopting the relevant recommendations in the current issues of British Standards BS 8303 and BS EN 15287-1.

Only use approved fuels on this appliance. Information about this can be found on Page 16.

This is a Domestic Appliance and must only be used in accordance with these instructions. Do not place articles that are affected by high temperatures on, or near, this appliance. Do not place furniture or other items within 1.2 metre of the front of this appliance. See the note on material clearances on pages 8/9.

Fitting a stove in a room which also contains an extractor fan and/or cooker hood should be avoided where possible. If this is unavoidable, the suitability of the space for fitting this appliance must be decided at the discretion of a qualified installer, and a flue draught interference test must be performed.

COMPETENT PERSONS SCHEME

Members of the following schemes may self-certify the installation of this stove. If the installer is not a member of one of these schemes, your local Building Control Department must approve the installation.

Scheme	Web address	Telephone
APHC (Association of Plumbing and Heating Contractors (Certification) Limited)	www.aphc.co.uk	02476 470 626
Building Engineering Services Competence Accreditation (BESCA Limited)	www.hvca.org.uk / www.besca.org.uk	0800 652 5533
HETAS Ltd (Heating Equipment Testing and Approval Scheme)	www.hetas.co.uk	01462 634721
NAPIT Registration Ltd	www.napit.org.uk	0870 444 1392
NICEIC Group Ltd	www.niceic.org.uk	0800 013 0900

HEALTH AND SAFETY PRECAUTIONS

Special care must be taken when installing the stove such that the requirements of the Health and Safety at Work Act are met.

PACKAGING

All packaging supplied with this stove can be re-used or recycled. Please contact your local authority for information on recycling schemes in your area.

HANDLING

Adequate facilities must be available for loading, unloading and site handling.

FIRE CEMENT

Some types of fire cement are caustic and should not be allowed to come into contact with the skin. In case of contact, wash immediately with plenty of water.

ASBESTOS

This stove contains no asbestos. If there is a possibility of disturbing any asbestos in the course of installation then please seek specialist guidance and use appropriate protective equipment.

METAL PARTS

When installing or servicing this stove, care should be taken to avoid the possibility of personal injury.

AIR SUPPLY

The room or space containing this appliance should have purpose provided ventilation (where necessary) in accordance with Building Regulations. Due consideration should be given to air requirements for any other appliance in the same room or space. Any air opening must be kept clear from blockage or obstruction.

MODIFICATION

No unauthorized modification of this appliance should be carried out.

SAFETY

WARNING – This appliance will be hot when in operation and due care should be taken. The supplied operating tool or gloves may be used to open the door and operate the air controls.

AEROSOLS – Do not use an aerosol spray on or near the stove when it is alight.

FIRES CAN BE DANGEROUS – Always use a fireguard in the presence of children, the elderly or the infirm. The fireguard should be manufactured in accordance with BS8423 – Fireguards for use with solid fuel appliances.

DO NOT OVER-FIRE – it is possible to fire the stove beyond its design capacity. This could damage the stove so watch for signs of over-firing. If any part of the stove starts to glow red, the stove is in an over-fire situation and the controls should be adjusted accordingly. Never leave the stove unattended for lengthy periods without first adjusting the controls to a safe setting. Careful air supply control should be exercised at all times.

FUME EMISSION – properly installed and operated, this appliance will not emit fumes. Occasional fumes from de-ashing and refueling may occur. Persistent fume emission must not be tolerated.

This appliance should not be operated with the door open.

If fume emission does persist then the following action should be taken immediately –

- Open Doors and windows to ventilate room.
- Let the fire out, or eject and safely dispose of fuel from the appliance.
- Check for flue/chimney blockage and clean if required.
- Do not attempt to relight the fire until the cause has been identified and corrected.
- If necessary seek professional advice.

ADVERSE WEATHER – In a small number of installations, occasional local weather conditions (e.g. wind from a particular direction) may cause downdraught in the flue and the stove to emit fumes. In these circumstances, the stove should not be used. A professional flue installer will be able to advise on solutions to this problem (e.g. anti-downdraught cowl).

IN THE EVENT OF A CHIMNEY FIRE -

- Raise the alarm
- Call the Fire Brigade
- Close appliance air controls
- Move furniture, ornaments etc. away
- Place a fireguard in front of stove
- Check the chimney breast for signs of excessive heat.

If the wall is becoming excessively hot, move furniture away. Ensure the Fire Brigade can gain access to your roof space in order to check for fire spread.

Installation

(N.B. All dimensions are in Millimetres)

APPLIANCE DIMENSIONS

DI LUSSO R6

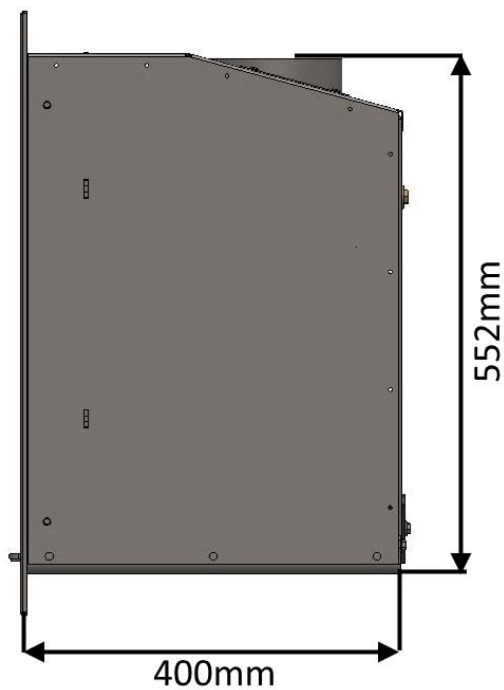
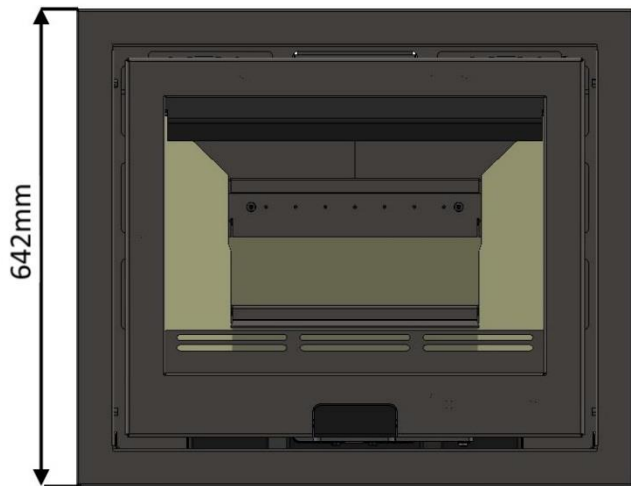
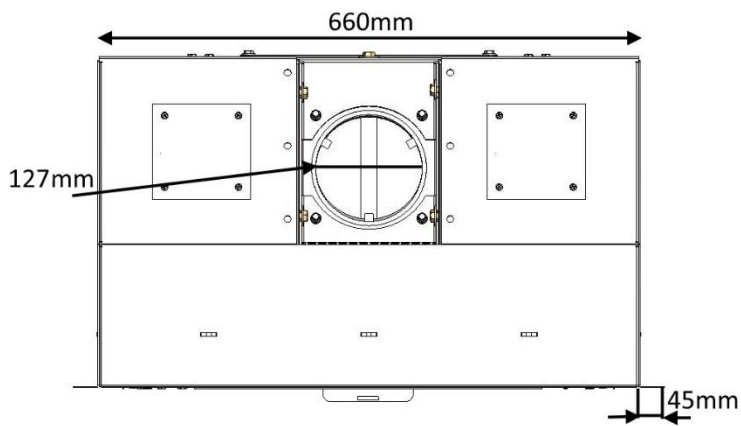

DI LUSSO R6 SLIMLINE

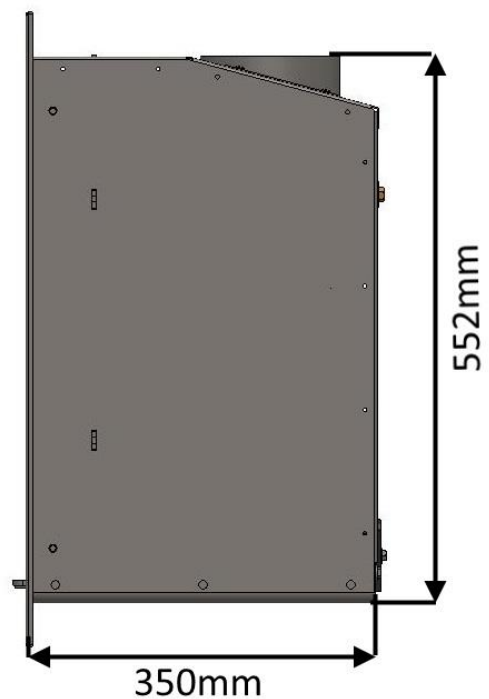
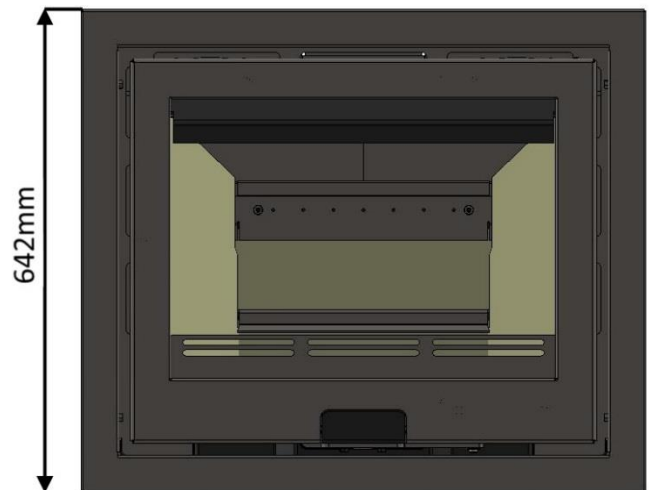
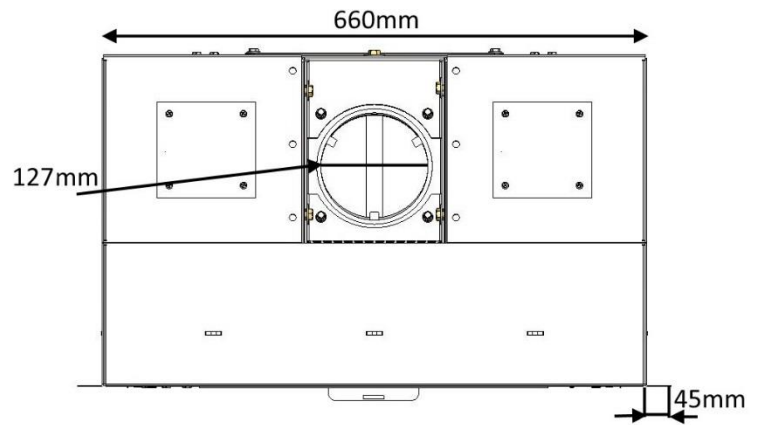

FLUE OUTLET POSITION

The flue outlet angle and position is determined by the orientation of the flue collar. The outlet can be either vertical or leant backwards by 30°. To change the angle, rotate the flue collar by 180°. The effective centre dimensions in millimeters are shown below.

DI LUSSO R6

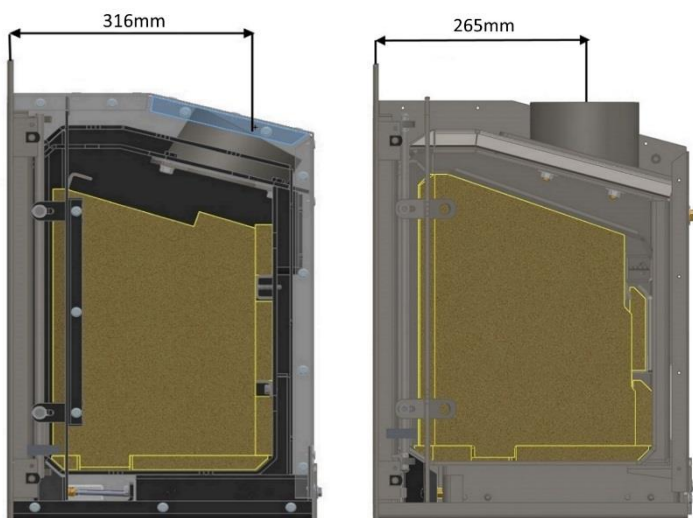

DI LUSSO R6 SLIMLINE

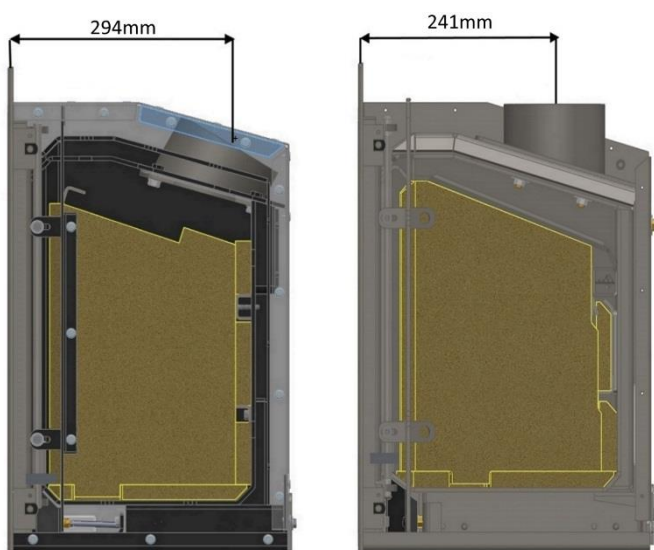

FLUE REQUIREMENTS

The flue serving this appliance must be dry, free from cracks and obstructions and be in accordance with the designations shown in **Table 1**.

The diameter of the flue should not be less than 127mm and not more than 200mm. If these requirements are not met the chimney should be lined by a suitable method.

If there is no existing chimney then either a prefabricated block chimney in accordance with Building Regulations Approved Document J or a twin-walled insulated stainless steel flue to BS EN 1856 can be used. These chimneys must be fitted in accordance with the manufacturer's instructions and Building Regulations.

<i>Flue Type</i>	<i>Minimum Designation</i>
Masonry or flue block flue with liner	T400 N2 D3 G (BS EN 1443:2003)
Clay Flue Blocks	FB1 N2 (BS EN 1806:2006)
Clay/Ceramic Liners	B1 N2 (BS EN 1457:2009)
Concrete Liners	B2 (BS EN 1857:2003)
Factory Made Metal Chimney	T400 N2 D3 G (BS EN 1856-1:2003)

Table 1 – Minimum Flue Designations

The chimney/flue should have a vertical height of at least 4.5 metres and should terminate in accordance with **Table 2**.

If the chimney is believed to have previously served an open fire installation, it is possible that the higher flue gas temperature from the stove may loosen deposits that were previously firmly adhered, with the consequent risk of flue blockage. It is therefore recommended that the chimney is swept a second time within a month of regular use after installation.

If you have any doubts about the suitability of your chimney, consult your local dealer/stockist.

Both the chimney and flue pipe must be accessible for cleaning and if ANY part of the chimney cannot be reached through the stove (with baffle removed), a soot door must be fitted in a suitable position.

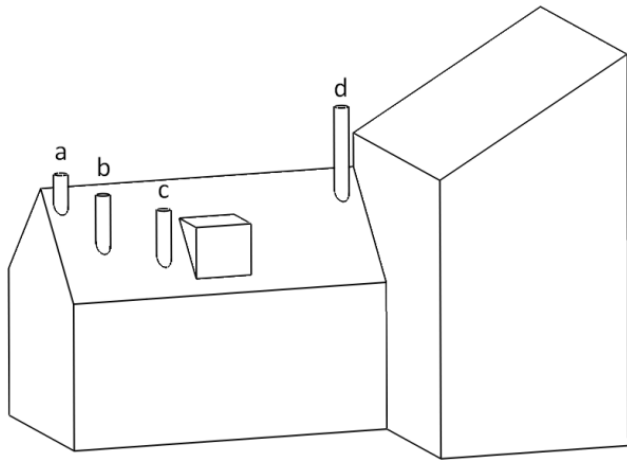

Terminal	Position	Clearances to Flue Outlet
a	At or within 600mm of the ridge	At least 600mm above the ridge
b	Elsewhere on a roof (whether pitched or flat)	At least 2300mm horizontally from the nearest point on the weather surface and: a) At least 1000mm above the highest point of intersection of the chimney and the weather surface or b) At least as high as the ridge
c	Below (on a pitched roof) or within 2300mm horizontally to an openable rooflight, dormer window or other opening.	At least 1000mm above the top of the opening.
d	Within 2300mm of an adjoining or adjacent building, whether or not beyond the boundary.	At least 600mm above any part of the adjacent building within 2300mm

Table 2 - Flue terminal positions

FLUE DRAUGHT

If the draught exceeds the recommended maximum, a draught stabiliser must be fitted so that the rate of burning can be controlled and to prevent over firing. If the reading is less than the recommended minimum then the performance of the appliance will be compromised. The flue draught should be checked under fire at high output.

Minimum Draught – 1.2mm Water Gauge

Maximum Draught – 2.5mm Water Gauge

DI LUSSO R6/R6 SLIMLINE

APPLIANCE OPENING

This stove must be fitted on a hearth or base with adequate load bearing capacity. The opening into which this stove is fitted should be constructed wholly from non-combustible materials. The dimensions of the opening should be **at least** those shown in the diagram. Ensure there is a sufficient overlap where the convection chamber flange meets the face of the opening. If not, either the opening should be made smaller, or a suitable fire surround should be fitted to reduce the opening dimensions.

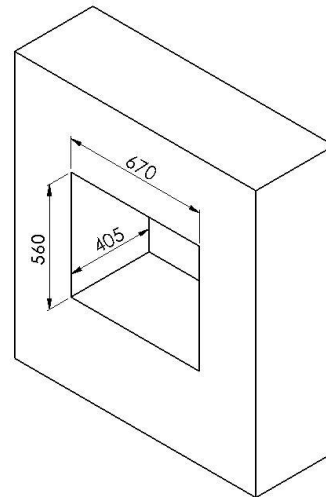

Any non-combustible walls within 50mm of this appliance should be at least 200mm thick and should extend at least 300mm above the top of the appliance and at least 1.2 metres above the hearth. Any walls more than 50mm from the appliance may be reduced to a thickness of 75mm. Ensure the inter-connecting flue pipe also has adequate clearances to combustible materials.

The wall above the stove will become hot and should therefore be finished in a heat resistant plaster. **IMPORTANT Do not hang pictures, electrical equipment or ornaments above the stove, as these could be damaged and could potentially create a fire hazard.**

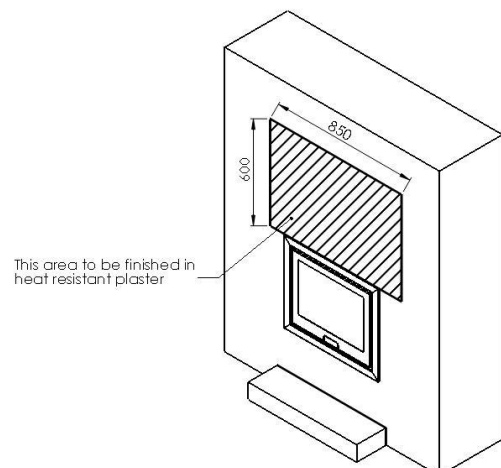

Please check the suitability of any fireplace/surround for closed solid fuel appliances before installation. Di Lusso cannot be held responsible for any fault arising through incorrect use or installation. Fire surround back panels suitable for solid fuel are usually in three sections and slatted. Many fire surrounds are suitable only for use with gas and electric fires and therefore not suitable for solid fuel.

DIRECT AIR ADAPTOR

If fitting the direct air adaptor kit the opening depth may need to be increased. Read the instructions supplied with the kit before proceeding.

HEARTH REQUIREMENTS

A constructional hearth with a minimum thickness of 125mm should be provided. The constructional hearth should be made of solid non-combustible material and can include any solid non-combustible floor. The boundary of the hearth must be clearly marked. This can be done by adding a super-imposed hearth on top of the constructional hearth – e.g. a slate slab on top of a solid concrete floor.

Appliances installed with the base plate lower than 560mm above the hearth should have a constructional hearth extending to at least 650mm in front of the stove and 150mm at the sides.

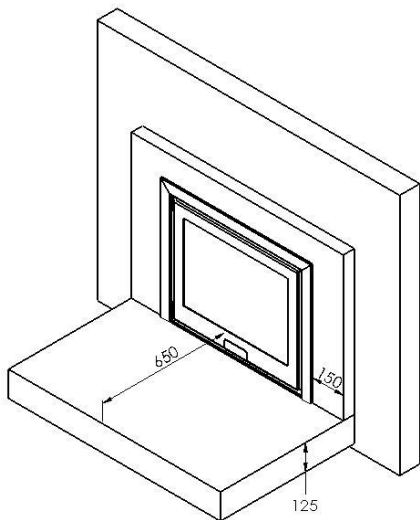

Appliances installed on a surface more than 560mm above the hearth require a constructional hearth with a depth of 225mm in front of the stove. The base on which the appliance is mounted should be an extension of the constructional hearth – ***i.e. all material between the stove base and the constructional hearth must be solid-noncombustible material.***

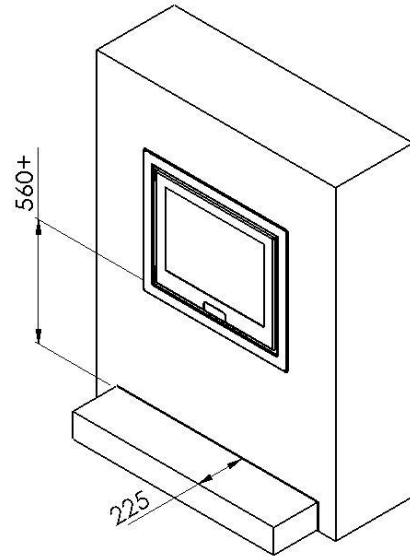

CLEARANCES TO COMBUSTIBLE MATERIALS

There should be no combustible materials for a distance of 400mm either side of the stove or 680mm above. No combustible furniture should be placed any closer than 1200mm from the front of the stove.

Allow sufficient clearance between the stove and pictures, electrical equipment or ornaments etc., as these could be damaged and could potentially create a fire hazard.

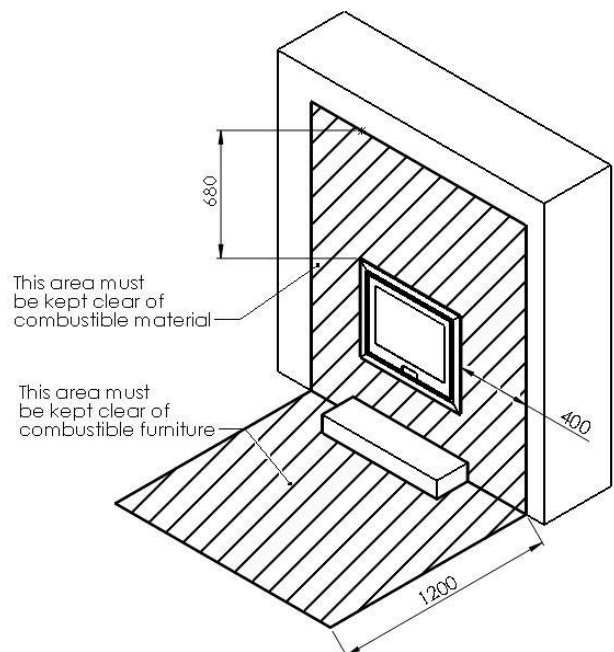

PREPARING THE STOVE FOR INSTALLATION

The firebox must be separated from the outer convection chamber prior to fitting the stove. This allows easier handling of the stove and protects the internal firebox from damage during the installation process. It is also recommended that the loose internal components (fire bricks and log retainer) within the firebox are removed.

1. To open the stove door, pull the door lever towards you to release from the magnet. Swing the handle out to the right until the mechanism engages and the door catch is released.

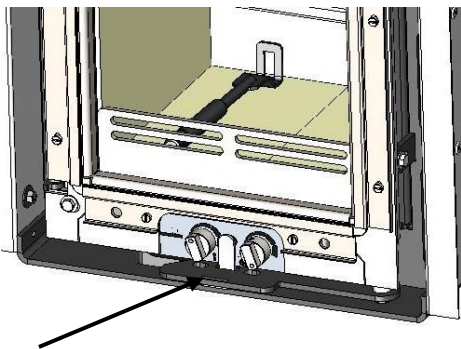

N.B. When closing the door keep the door handle out to the right until the door is closed.

2. Remove the nuts, washers and M8 x 25mm studs located at either side of the flue outlet.

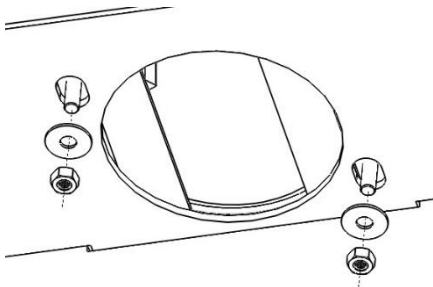

3. Remove the Air Valve Cassette by removing the two fixing screws holding it in place, turning both air controls fully clockwise and gently pulling on the fascia to slide the cassette out from under the firebox.

N.B DO NOT remove the Air Valve Cassette with the controls in the closed position as this will damage the valve gaskets.

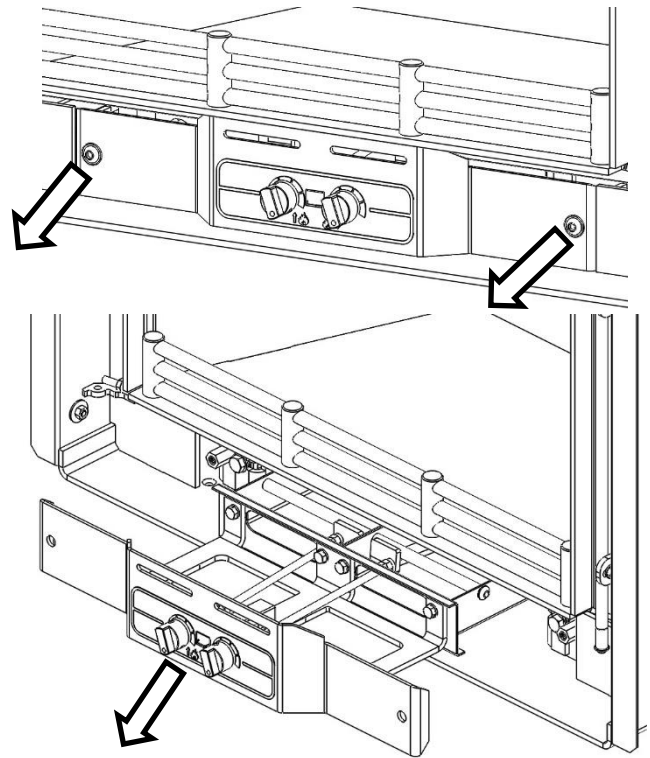

4. Remove the two fixing screws located on the firebox legs.

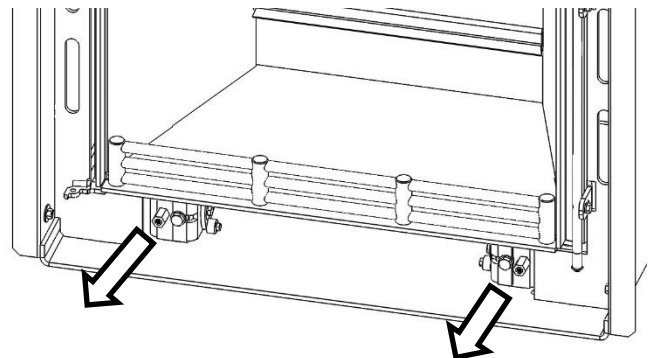

5. Carefully slide the firebox out from the convection chamber, remove any packaging and put the firebox and Air Valve Cassette in a safe place. These parts will not be needed again until the final stages of the installation.

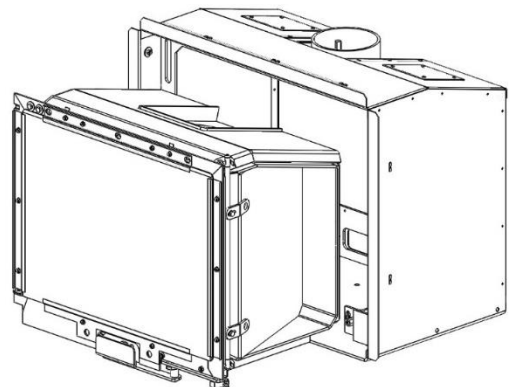

FITTING THE STOVE – BOTH

IMPORTANT – Read this section carefully and ensure that any required access holes, register plates or flue connections are in place before carrying out the installation.

If the installation is to be back filled with vermiculite concrete the convection chamber flange should be sealed to the fireplace using fire cement, heat proof silicone or similar. All seams in the convection chamber should also be sealed.

It is recommended that the convection chamber flange is sealed to the fireplace in all cases as this will reduce the chance of airflow into any voids reducing the stoves efficiency or the ingress of unpleasant smells into the room.

If fitting the Direct Air Adaptor Kit the instructions supplied with the kit should be read in conjunction with these instructions.

1. Offer the convection chamber into position in the recess pushing it back far enough so that the flanges on the edges are pushed up tightly against the front face of the chimney breast/fireplace.
2. Drill a 6mm hole into the hearth in the centre of the base plate fixing hole. Use the screw supplied to fix the stove in place.

Any voids around the stove must be In-filled with vermiculite concrete with a recommended mix of six parts vermiculite to one-part Ordinary Portland Cement. This may be carried out once the flue has been fitted provided a suitable access hole for backfilling is made in the chimney breast (see section on connecting to a masonry chimney). Sufficient water should be added so that when a handful of the mixture is squeezed no more than one or two drops of water are released.

FLUE CONNECTION

The flue connection is made to the convection chamber and not to the firebox. The connection between the flue and firebox is completed when the firebox is re-fitted to the convection chamber.

Dependent on the type of installation the flue collar may need to be connected to the convection chamber before or after installation of the flue/liner.

1. Determine the required orientation of the flue collar (vertical or leant backwards by 30°).
2. Offer the flue collar into position from inside the convection chamber and fix in place using the four M8 countersunk screws. **Ensure that**

the screw heads are not proud of the flue collar flange.

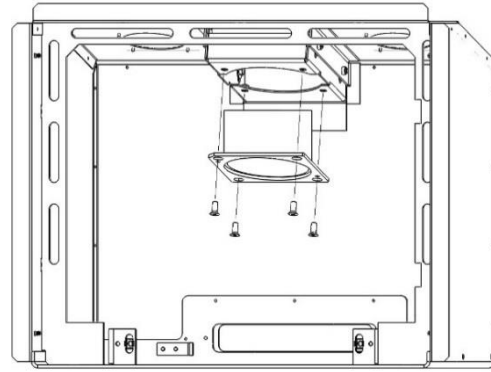

If connecting to a stainless-steel liner, the flue liner and single skin adaptor can be lowered down the chimney and the spigot end of the adaptor lowered into the firebox. The flue collar can then be connected to the adaptor.

The completed flue collar assembly can then be pushed up to the top plate of the stove and secured in position using the four M8 nuts and washers. Check the clearance of the flue liner adaptor through the top of the stove before deciding on this method.

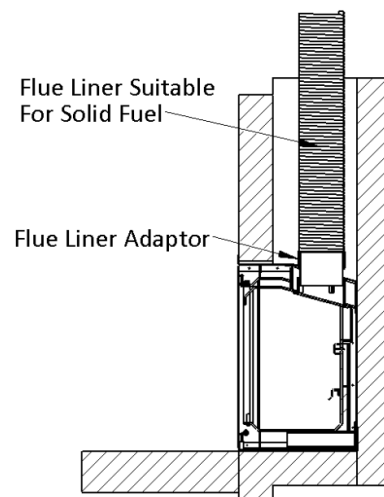

If connecting to an existing masonry chimney it is recommended that a flue forming pipe (short length of flue pipe) is used and the void between the flue forming pipe and the chimney filled with vermiculite concrete.

A suitable access hole will need to be made in the chimney breast to allow the back filling to be carried out and then filled and sealed once the installation is complete. Alternatively, a connection can be made using a register plate although it will be necessary to allow access for fitting the flue pipe to the register plate and sealing all joints.

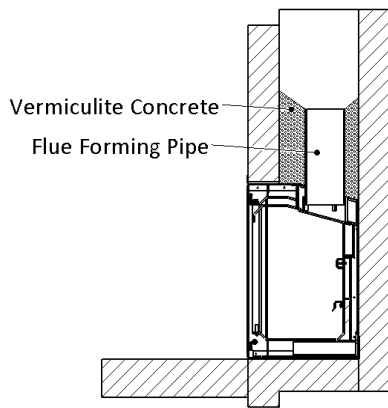

Alternatively, a connection can be made using a register plate although it will be necessary to allow access for fitting the flue pipe to the register plate and sealing all joints.

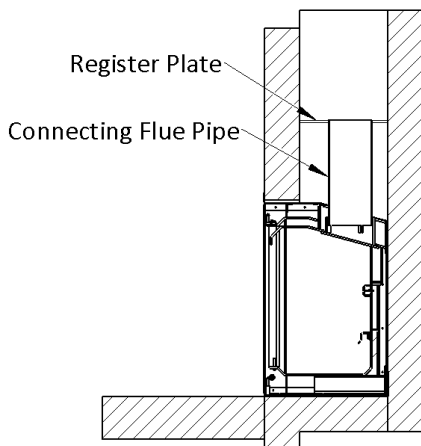

INSTALLATION INTO A NON-COMBUSTIBLE ENCLOSURE **BOTH**

The Di Lusso R6 and R6 Slimline has been designed, tested and approved to be installed either into solid non-combustible material or into an enclosure according to the following specification. It is the duty of the installer to ensure that the requirements of this specification and all relevant standards are met.

- *There must be no combustible material within the construction of the enclosure.*
- *The stove should be supported on the Di Lusso enclosure stand (part no. HMR05ARRT013).*
- *The enclosure must be produced from 30mm Skamol Super Isol board, held together with a non-combustible framework and finished in heat resistant plaster.*
- *Particular attention must be paid to the size and position of ventilation openings. These openings must be kept clear at all times.*
- *All flue pipe within the enclosure must be insulated twin-wall flue pipe suitable for*

solid fuel as specified in Table 1 on page 7 (factory made metal chimney)

- *If fitting the Direct Air Adaptor Kit, the adaptor box and ducting must be insulated with 30mm thick Rockwool Rocklap H&V Pipe Sections, having a nominal density not less than 120kg/m³.*
- *If fitting the Convection Duct Kit, the ducting within the enclosure must also be insulated with 30mm thick Rockwool H&V Pipe Sections, having a nominal density not less than 120kg/m³ as per the instructions supplied with the kit.*
- *The clearances to combustible material shown on page 9 must be met (N.B the side distance is for material proud of the front face of the wall).*
- *The enclosure should be stood wholly above a non-combustible hearth with a minimum thickness of 12mm. The hearth should extend at least 225mm in front of the stove and 150mm either side. The hearth may be super-imposed*

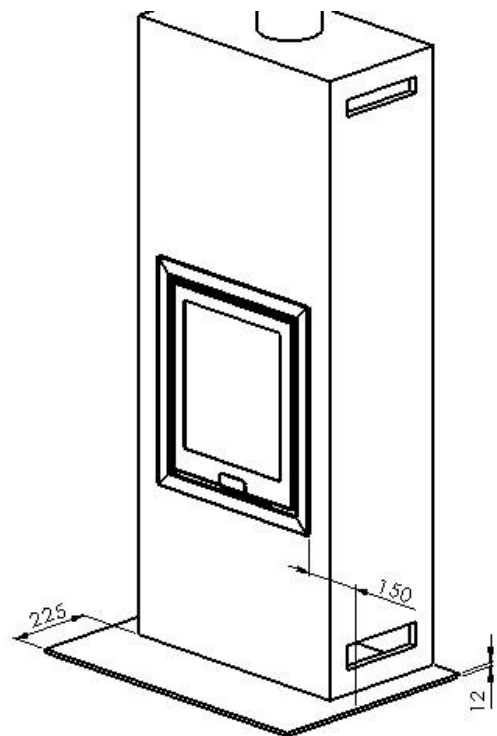

Di Lusso R6/R6 Slimline Enclosure Details (all dimensions in millimetres)

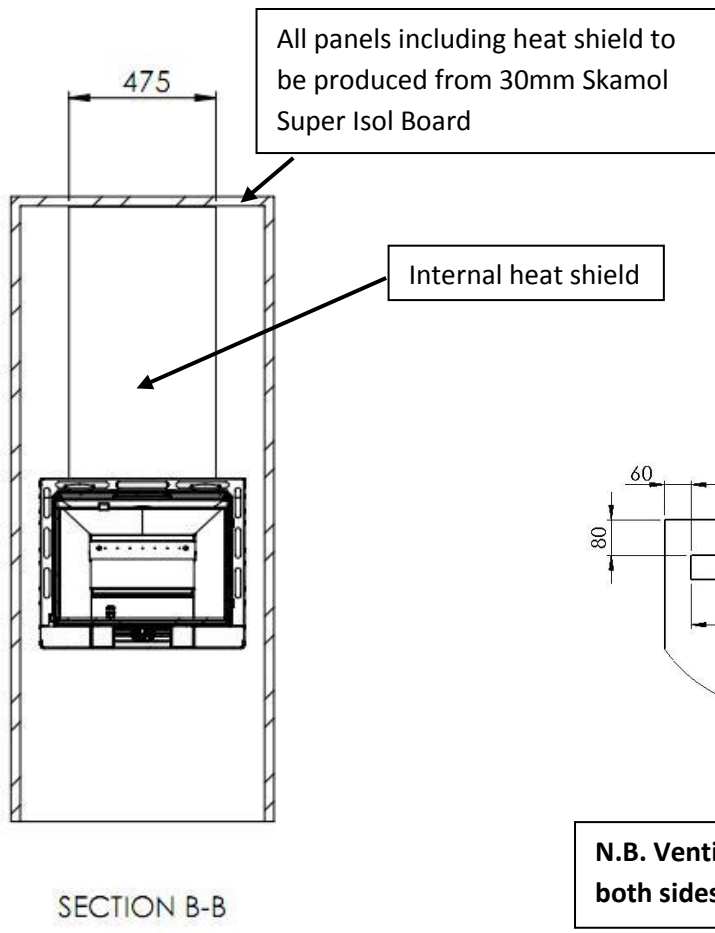
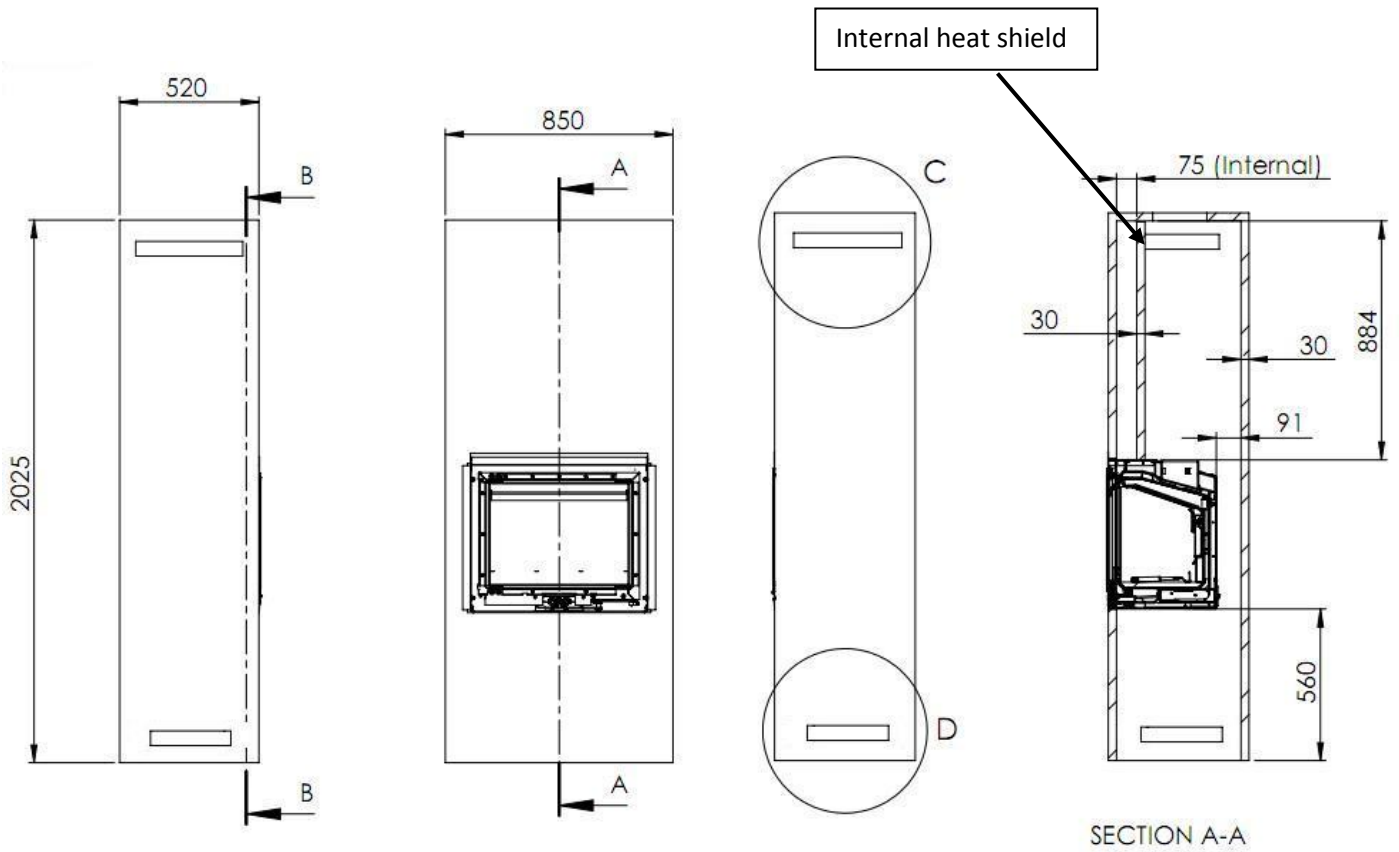

N.B. Ventilation openings are identical on both sides of the enclosure.

RE-ASSEMBLING THE STOVE

1. Smear a bead of fire cement around the flue hole on the outside of the firebox.

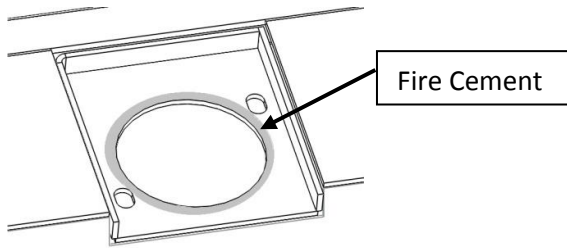

2. Offer the firebox into position and slide it back as far as possible.
3. Refit the fixing screws through the firebox legs. Tighten the screws equally to draw the firebox into place. **Do not over-tighten!**
4. Refit the two M8 x 25mm studs into the two fixing holes around the flue outlet. Fix in place with the washers and nuts.
5. Wipe off any excess fire cement around the inside of the flue which may have been squeezed out when fitting the firebox.

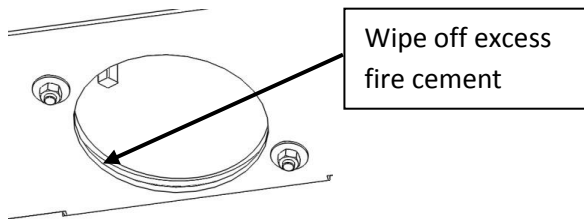

6. Refit the firebricks and log retainer.
7. Check that the valves are in the fully open position (fully clockwise) and refit the Air Valve Cassette.
8. Close the stove door.
9. Refit the two fixing screws through the holes in the Air Valve Cassette fascia.
10. Unpack the Flue Baffle and identify the two halves –

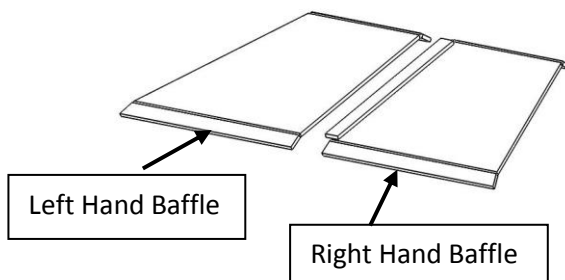

11. Stack the two baffle halves with the right-hand baffle sat on top of the left-hand baffle as shown –

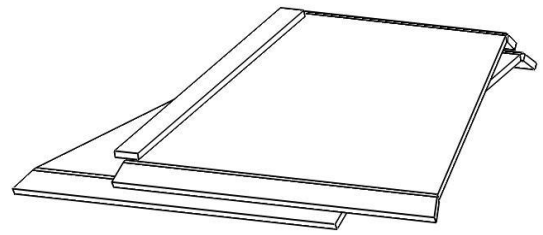

12. Lift the two baffles up together inside the firebox to the right-hand side of the baffle support bracket, slide the baffles to the left and rest them on the support bracket at the front of the stove and Tertiary Air Bar.

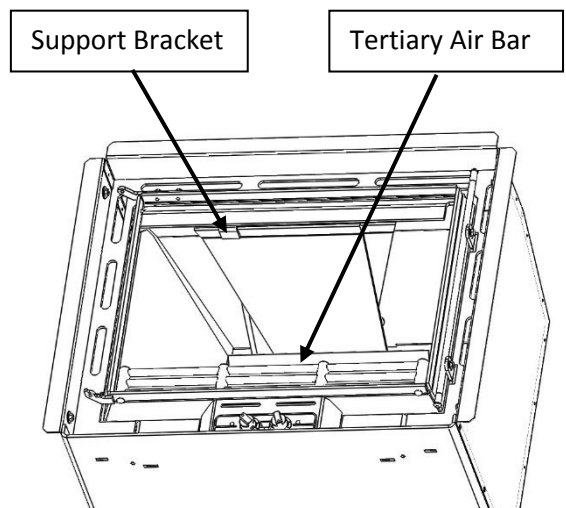
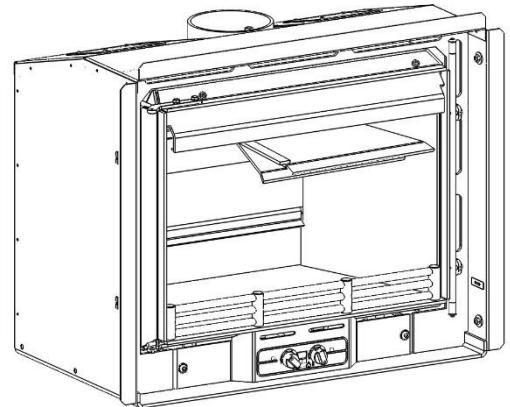

- Slide the Left hand baffle to the left and the right hand baffle to the right, push them towards the rear of the firebox so that the baffles drop down and sit tightly together as shown.

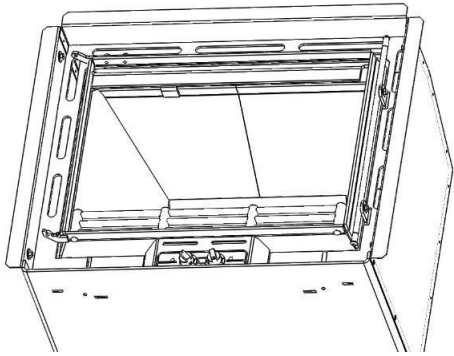

FITTING THE FRAME PACK

- Loosen the four M6 Nuts to the ends of the studs on the convection chamber sides.

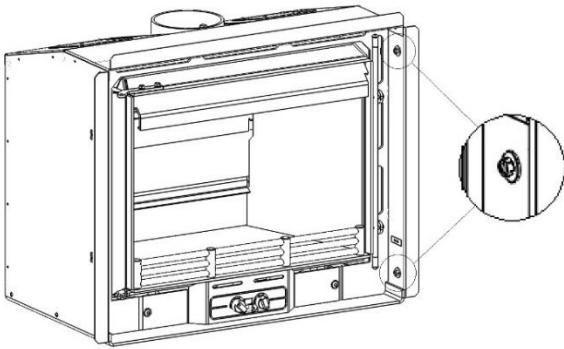

- Slide the frame into position, making sure that the lower inner edge of the frame is in line with the base of the stove, and tighten the nuts with a 10mm spanner.

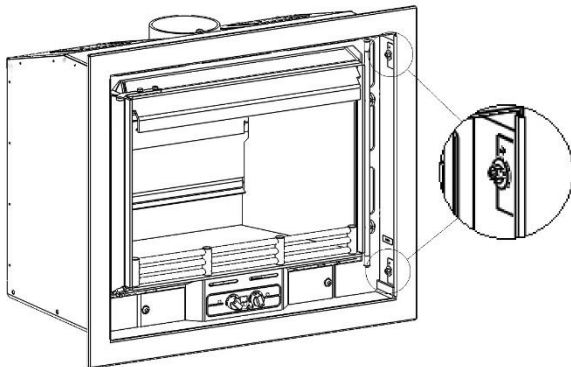

- Place a round spacer (supplied with the frame pack) over each of the fascia studs.

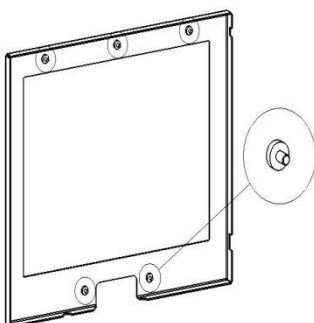

- Offer the door fascia into position, passing the three M6 studs through the holes. Ensure that the fascia is resting on the two clips at the top of the door and fix in position using the nuts and washers provided.

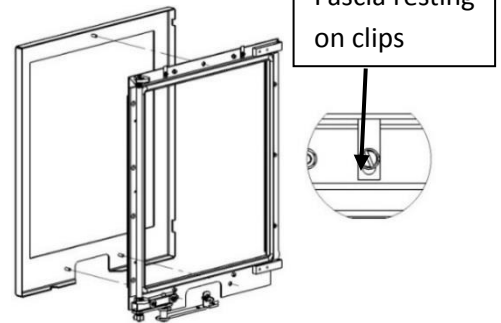

- Close the door and check that there is an even gap between the frame and door fascia on the left and right-hand sides (approximately 16mm). Adjust as Necessary.

COMMISSIONING

Upon completion of the installation, allow a suitable period of time for any fire cement and mortar to dry out. A small fire may then be lit and the installation checked to ensure the smoke and fumes are drawn up the flue and emitted safely to atmosphere. The stove should not be run at full output for at least 24 hours.

Read the Operating Instructions before lighting the stove for the first time.

Leave the instructions and operating tool(s) with the customer and advise them on -

- Correct use of the appliance
- The recommended fuel
- Action to be taken should smoke or fumes be emitted from the stove or installation.
- The use of a fireguard when the stove is used in the presence of children or the infirm.

Operating Instructions

Read the 'General Guidance' Section at the start of these instructions before operating your stove for the first time.

IMPORTANT! - Do not hang pictures, televisions or combustible ornaments above the stove, as these could be damaged and could potentially create a fire hazard (For more information read the 'Clearance Distances to Combustibles' section of the installation instructions).

WARNING! – This appliance will be hot when in operation and due care should be taken. The supplied operating tool or gloves may be used to open the door and operate the air controls.

THE CLEAN AIR ACT 1993 AND SMOKE CONTROL AREAS

Under the Clean Air Act local authorities may declare the whole or part of the district of the authority to be a smoke control area. It is an offence to emit smoke from a chimney of a building, from a furnace or from any fixed boiler if located in a designated smoke control area. It is also an offence to acquire an "unauthorised fuel" for use within a smoke control area unless it is used in an "exempt" appliance ("exempted" from the controls which generally apply in the smoke control area).

In England appliances are exempted by publication on a list by the Secretary of State in accordance with changes made to sections 20 and 21 of the Clean Air Act 1993 by section 15 of the Deregulation Act 2015. Similarly, in Scotland appliances are exempted by publication on a list by Scottish Ministers under section 50 of the Regulatory Reform (Scotland) Act 2014.

In Northern Ireland appliances are exempted by publication on a list by the Department of Agriculture, Environment and Rural Affairs under Section 16 of the Environmental Better regulation Act (Northern Ireland) 2016.

In Wales appliances are exempted by regulations made by Welsh Ministers.

Further information on the requirements of the Clean Air Act can be found here:

<https://www.gov.uk/smoke-control-area-rules>

Your local authority is responsible for implementing the Clean Air Act 1993 including designation and supervision of smoke control areas and you can contact them for details of Clean Air Act requirements.

The Di Lusso R6 and R6 Slimline have been recommended as suitable for use in smoke control areas when burning wood logs.

Refuelling on to a low fire bed

If there is insufficient burning material in the firebed to light a new fuel charge, excessive smoke emission can occur. Refuelling must be carried out onto a sufficient quantity of glowing embers and ash that the new fuel charge will ignite in a reasonable period. If

there are too few embers in the fire bed, add suitable kindling to prevent excessive smoke.

Fuel overloading

The maximum amount of fuel specified in this manual should not be exceeded, overloading can cause excess smoke.

Operation with door left open

Operation with the door open can cause excess smoke. The appliance must not be operated with the appliance door left open except as directed in the instructions.

Dampers left open

Operation with the air controls or appliance dampers open can cause excess smoke. The appliance must not be operated with air controls, appliance dampers or door left open except as directed in the instructions.

RECOMMENDED FUEL

IMPORTANT! – Use only recommended fuels

This appliance is designed and approved to burn wood logs with a moisture content not exceeding 20%. The maximum recommended log length is 250mm and the maximum recommended log diameter is 100mm.

Do not load fuel higher than the bottom of the compound tertiary cover!

Burn only dry, well-seasoned wood, which should have been cut, split and stacked for at least 12 months, with free air movement around the sides of the stack to enable it to dry out. Burning wet or unseasoned wood with a moisture content in excess of 20% will create tar deposits in the stove and chimney, increase harmful emissions and will not produce a satisfactory heat output. ***Do not burn waste, coal or petroleum coke fuels or treated or painted wood in this appliance (e.g. pallet wood) as this will invalidate your warranty.***

AIR CONTROLS

Installed and used correctly, this stove will burn cleanly and efficiently. Therefore, to avoid the disappointment of poor performance or dirty glass, please familiarize yourself with the controls and their recommended settings before use.

To prevent excess smoke emissions, the air controls of this appliance must only be operated as directed in the instructions.

To access the air controls, pull the door lever towards you to release it from the magnet and swing it to the right

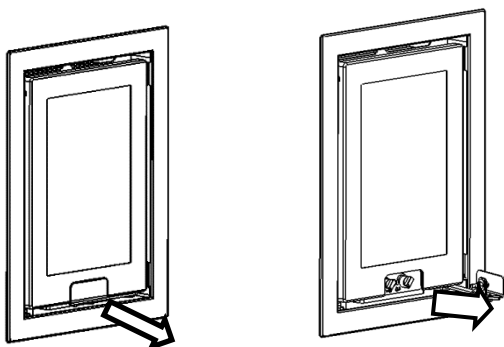

If the door handle is swung past the point where resistance is felt, the door will be unlatched and may swing open.

When the stove is hot the door, handle can be opened by using a glove or by putting the head of the operating tool into the slot in the door lever and pulling it towards you.

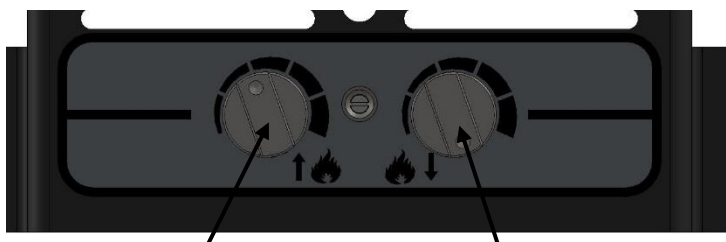

Ignition Air Control Combustion Air Control

Ignition Air control – regulates air flow directly into the firebed. This is used when lighting from cold or when reviving a fire that has nearly burnt out. Turn clockwise to open and anti-clockwise to close. **The Ignition Air Control must be closed once the fire is established.**

Combustion Air Control – regulates the flow of air downwards into the combustion chamber via the airwash (airflow over the inside of the glass) and air inlet holes in the back of the firebox. Turn clockwise to open and anti-clockwise to close. **This control is used to regulate the burn rate and therefore heat output of the stove.**

Tertiary Air – Tertiary Air enters the firebox through the series of holes in the rear wall. This air supply

helps to reduce emissions into the atmosphere. The tertiary air supply is fixed and cannot be adjusted.

N.B. When closing the door, keep the door handle out to the right until the door is closed.

LIGHTING

We recommend that you have two or three small fires before you operate your stove to its maximum heat output. This is to allow the paint to cure in steadily and to give a long service life to the paint finish. During this curing in process, you may notice an unpleasant smell. It is non-toxic, but for your comfort we would suggest that during this period you leave all doors and windows open.

Open both air controls fully and light one or two firelighters placed centrally on the bottom of the firebox, allowing the flames to become established before placing several pieces of small dry kindling in a crisscross fashion above the firelighters, taking care not to smother the fire. Close the stove door. Once the kindling is well alight, open the door and build the fire by gradually adding slightly larger pieces of wood, closing the door afterwards.

Once the fire is established, close the Ignition Air Control (anti-clockwise) and add more fuel as necessary. The Combustion Air control can now be used to regulate the burn rate of the stove (see Recommended Settings).

Should the fire fail to light correctly, open the door and use a poker to spread the fuel across the bottom of the firebox. Close the door and allow the fuel and stove to cool before attempting to relight the fire.

N.B. Leaving the air controls in the closed position, adding too much fuel or using wood that is wet or too large will prevent the fire from establishing correctly and may result in smoke emission from the stove.

When the stove is up to operating temperature, the operating tool or gloves should be used to operate the air controls.

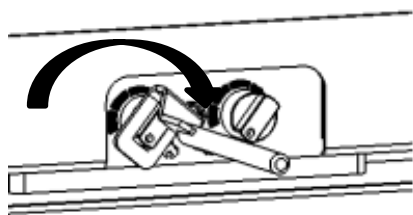

RECOMMENDED SETTINGS

Once the fire is established, the Ignition Air Control should be fully closed and the Combustion Air Control turned to a setting of approximately 40-50% open. This setting should allow the nominal output and efficiency to be achieved.

Avoid running the stove on very low air settings as this could result in a reduction in efficiency and increase emissions into the atmosphere.

REFUELLING

Avoid refueling on to a low firebed as this may cause excessive smoke emission. Ensure there are sufficient embers to ignite the new fuel load rapidly. Alternatively add some more kindling before adding larger pieces of firewood.

Do not add firewood above the level of the tertiary air inlet at the back of the stove. Exceeding this amount can result in the production of excessive smoke.

DE-ASHING

From time to time it will be necessary to remove excess ash from the firebox. This can be done by lifting up the log retainer to release it from its supports and removing the ash with a small shovel.

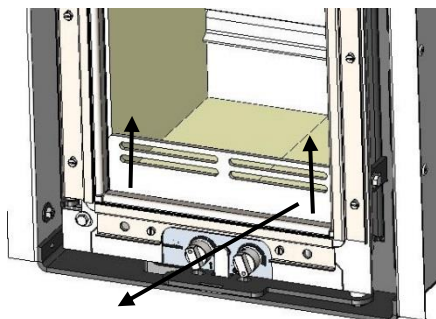

Maintenance

Important! –In order to ensure continued compliance with current Building Regulations, Local Authority Byelaws and the Clean Air Act (if applicable), this

appliance requires regular maintenance of the following –

N.B. Refer to the ‘Removing Internal Components’ section of the installation instructions for details on how to remove each component.

MONTHLY

Baffle Brick – this should be removed and cleaned at least once a month to prevent any buildup of soot or ash that could lead to blocked flue ways. With the baffle removed, the chimney can be swept through the appliance.

Firebricks- in normal use, these can last for many years. It is possible however, to damage them if care is not taken when refueling the stove. Check periodically for seriously cracked bricks, which would need to be replaced with new.

Air Valve Cassette- this should be removed and cleaned monthly to remove any ash that may be in the controls. ***N.B. Make sure that controls are in the maximum position (fully clockwise) before removing the Air Valve Cassette.***

Glass Panel- Printed glass should not be cleaned using cleaners high in alkaline or acidic content. Clean the glass panel when cool with a propriety glass cleaner by applying the cleaner to a cloth. Do not apply directly to the glass as this could cause run off, which could soak into the rope seals around the edge of the glass. Highly abrasive substances should be avoided as these can scratch the glass and make subsequent cleaning more difficult. Wet logs on heated glass, a badly aimed poker or heavy slamming of the doors could crack the glass panels. The glass will not fracture from heat.

Rope – if the rope around the door is becoming detached use, proprietary rope adhesive to re-attach it. If the rope is in poor condition, it will need replacing.

All spares can be ordered from our website www.hunterstoves.co.uk/spares or from your dealer.

ANNUALLY

Annual maintenance of the following should be carried out by a competent person –

Chimney and flue ways- it is important that the chimney, flue ways and any connecting pipe are swept regularly. This means at least twice a year for

Woodburning appliances. Only wire-centred sweeps' brushes fitted with a guide wheel should be used. If it is not possible to sweep all parts of the chimney through the appliance, ensure there is adequate access to cleaning doors.

If the stove is fitted in place of an open fire, the chimney should be swept one month after installation to clear any soot falls which may have occurred due to the difference in combustion between the stove and the open fire.

PERIODS OF PROLONGED NON-USE

If the stove is to be left unused for a prolonged period, then it should be given a thorough clean to remove ash and unburned fuel residues. To enable a good flow of air through the appliance to reduce condensation and subsequent damage, leave the air controls fully open.

If the appliance has been unused for a prolonged period, such as the spring and summer months, a competent person should check the chimney for potential obstructions before lighting the stove *i.e. get the chimney swept before the start of the heating season.*

AS NECESSARY

Stove body – The stove is finished with a heat resistant paint and this can be cleaned with a dry microfiber cloth or a dry soft brush only. Do not clean whilst the stove is hot. **At no point should any water based or other cleaning products be used on the stove.** The finish can be renovated with Hunter Stoves paint.

Door Catch – Over time, the rope seal in the door will become compressed. It may therefore be necessary to adjust the door catch to maintain the door seal. To adjust the catch, slacken the two set screws on the catch bar and adjust the position of it as necessary.

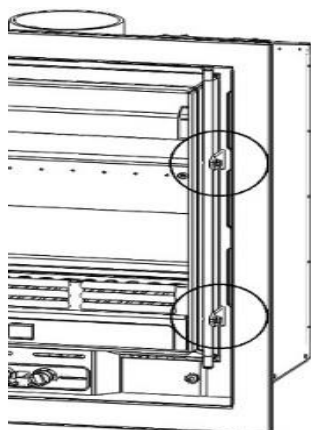

Air Valves - Over time, the sealing face of the air valves may wear. This will reduce the effectiveness of the controls. To replace a worn valve, remove the air valve cassette, lift off the worn valve and replace with new.

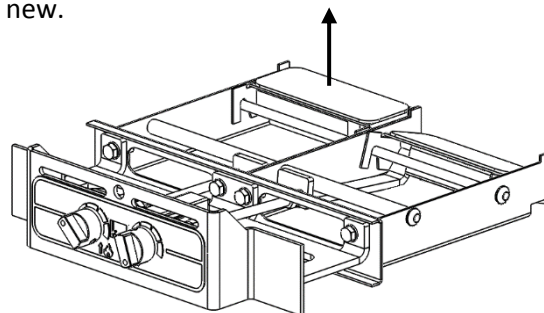

Trouble Shooting

FIRE WILL NOT BURN

Check that –

- The air inlet or slots in the front of the stove are not obstructed in any way.
- Chimneys and flue ways are clear.
- A suitable fuel is being used.
- There is an adequate air supply into the room.
- An extractor fan is not fitted in the same room as the stove.
- Flue draught is above minimum level (see installation instructions).

FIRE BLAZING OUT OF CONTROL

Check that –

- The door is tightly closed.
- The air controls are in the closed position.
- A suitable fuel is being used.
- The glass is not loose.
- The door rope seal is in good condition.
- The air valve sealing faces are not worn
- Flue draught is below maximum level (see installation instructions).

SPARES

DI LUSO R6 BODY SPARES

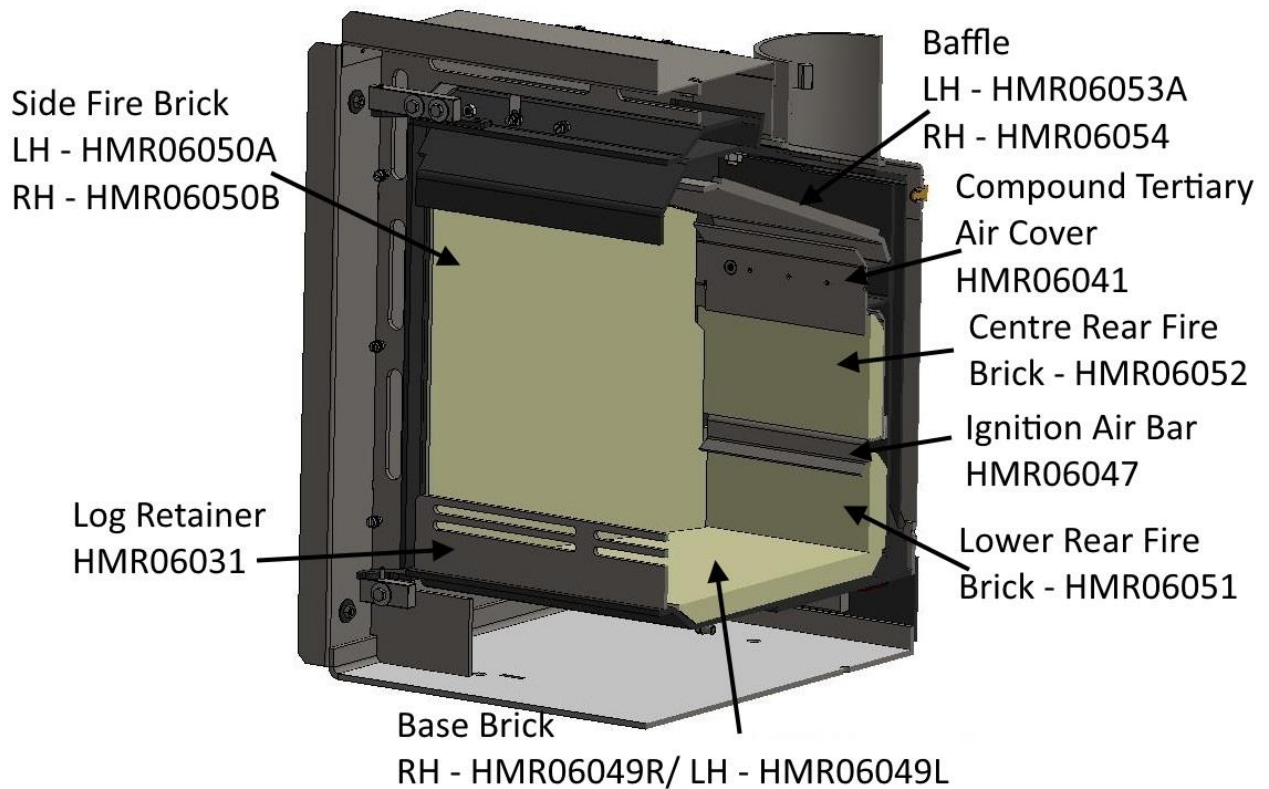

DI LUSO R6 SLIMLINE BODY SPARES

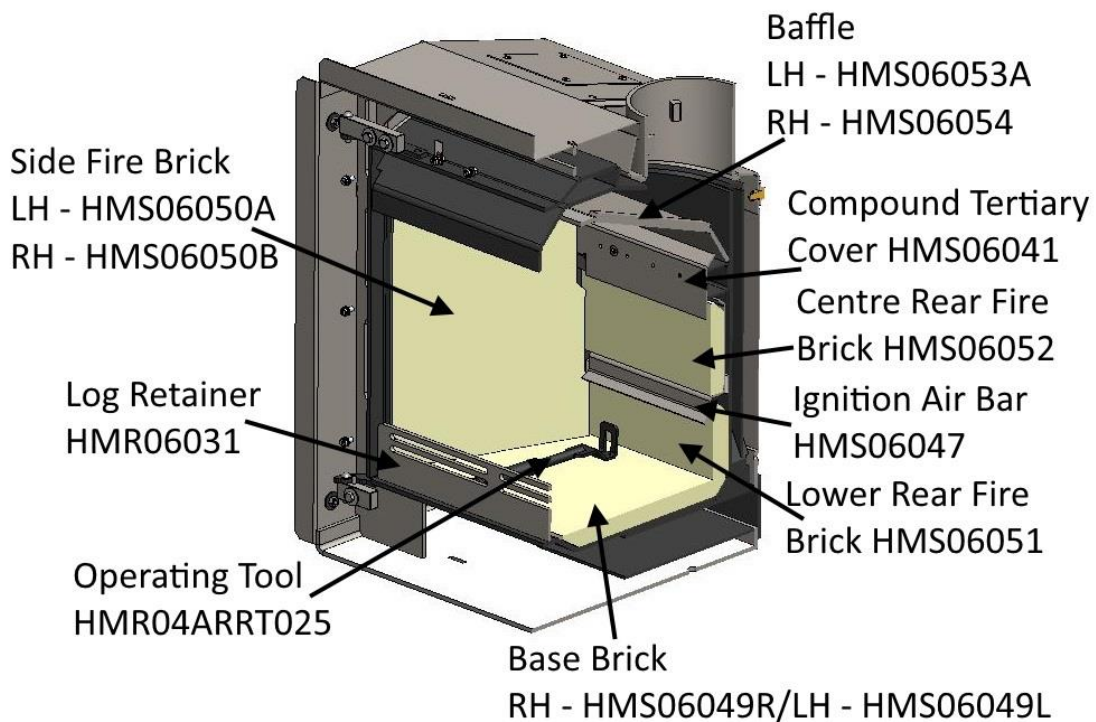

DOOR SPARES

DI LUSO R6 – COMPLETE DOOR CODE: HMR06ARRT005

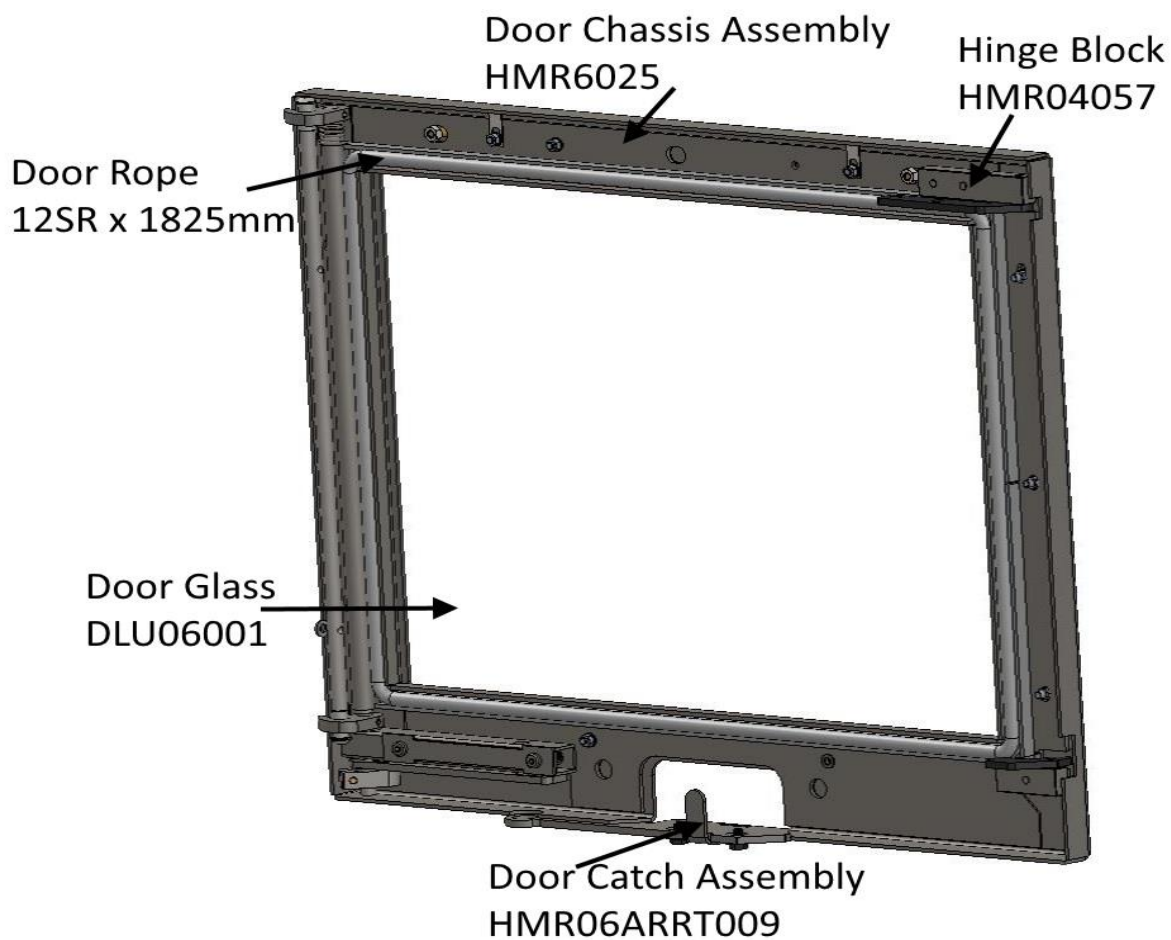
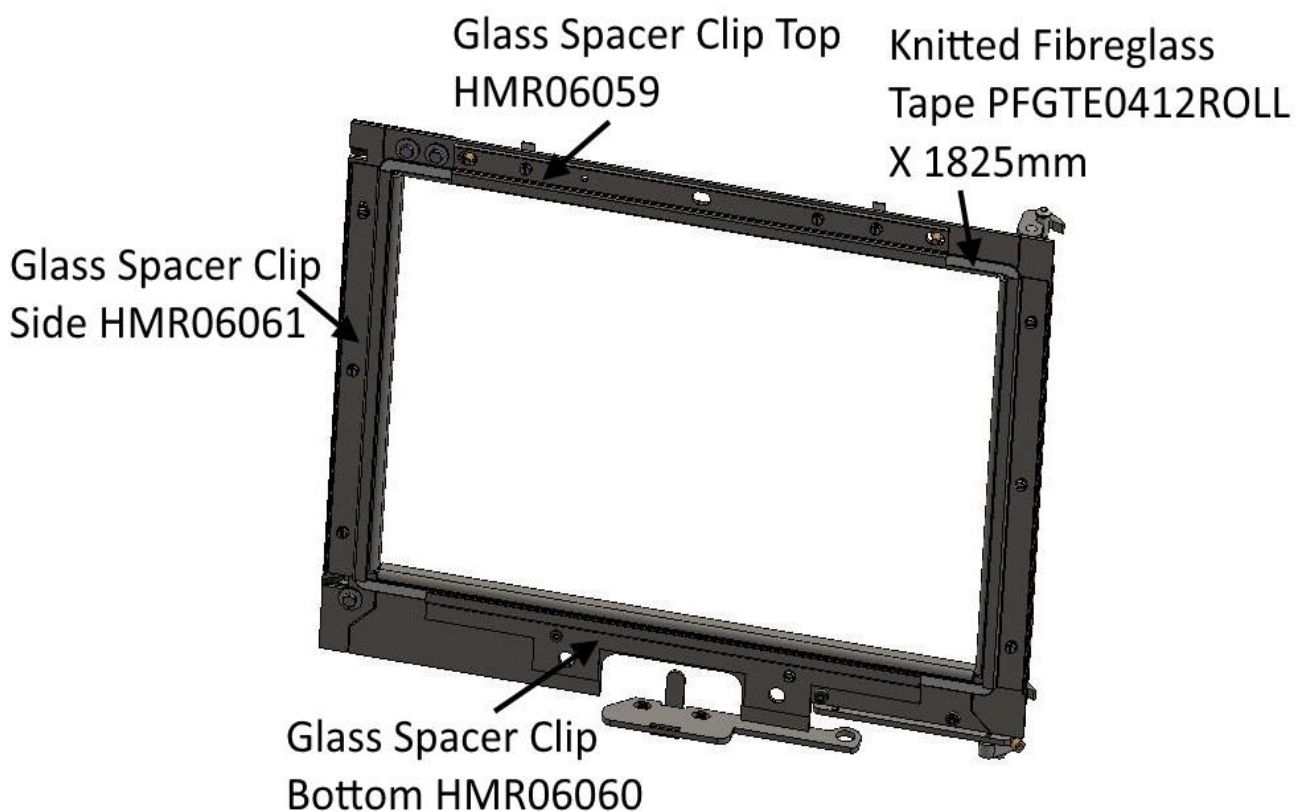

Stove Spares

Air Valve Cassette Spares

R6 – COMPLETE AIR VALVE CASSETTE: HMR06ARRT006

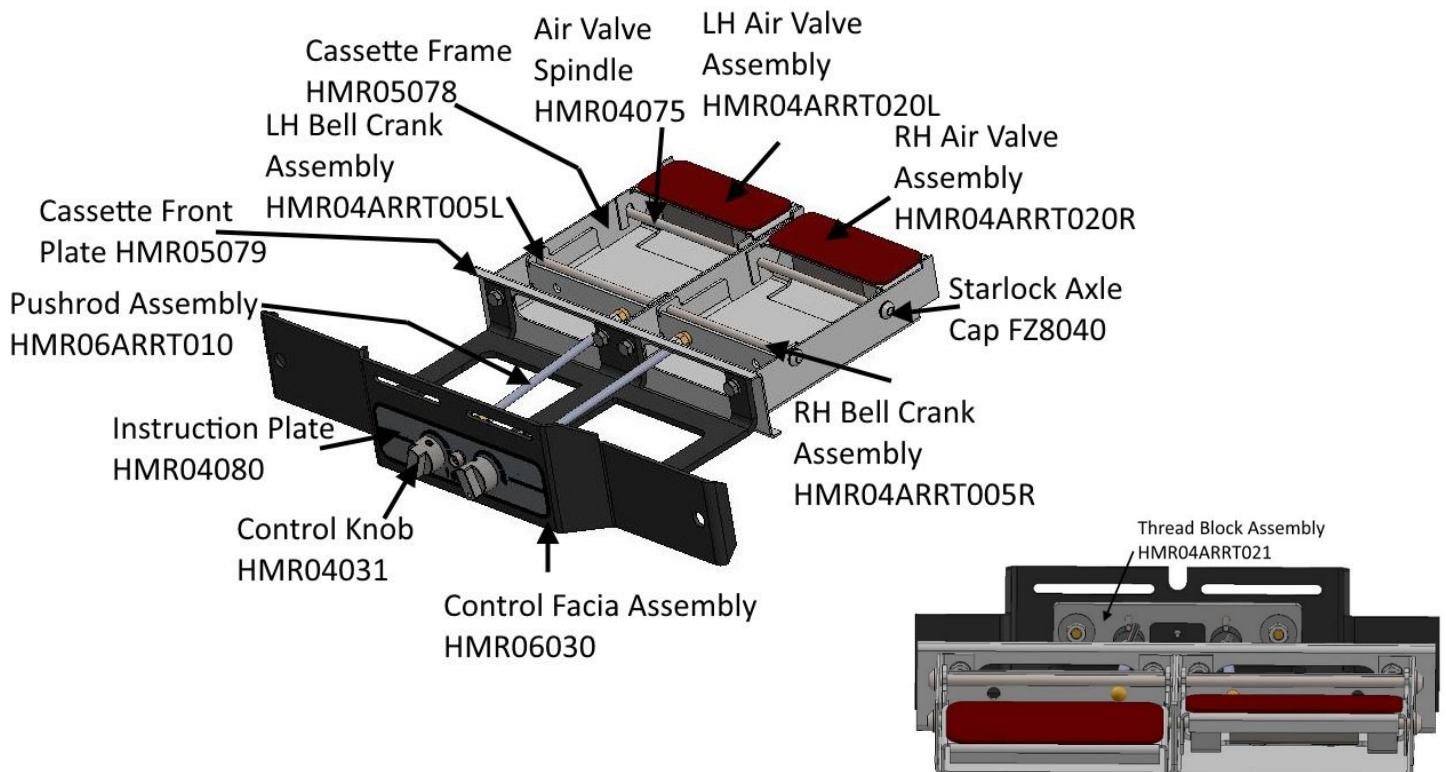

R6 SLIMLINE – COMPLETE AIR VALVE CASSETTE: HMR05ARRT006

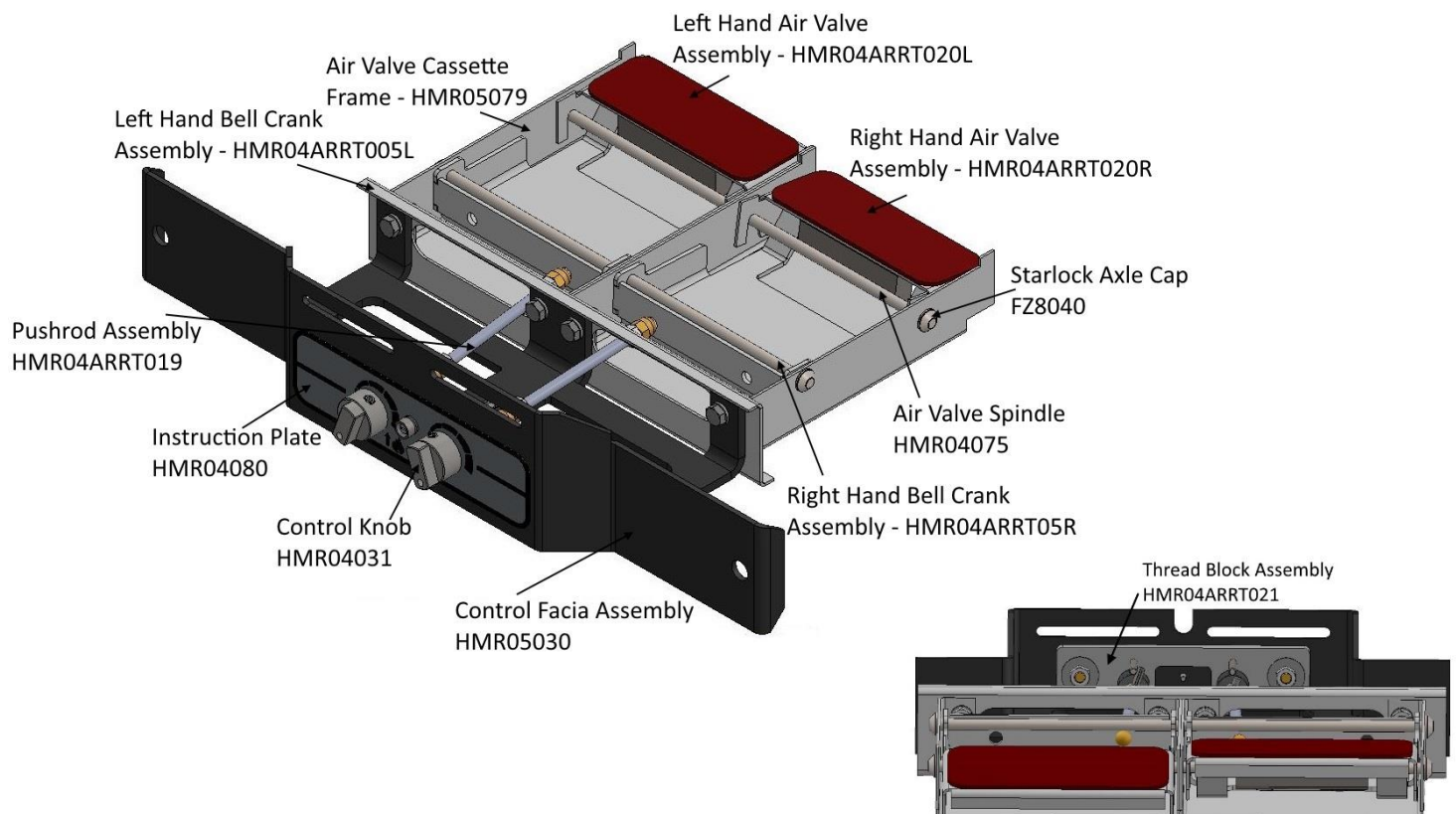

INSTALLATION & COMMISSIONING CHECKLIST

PURCHASE INFORMATION		
Dealer/Retailer Name		
Address		
Telephone Number		
Email		
Date Purchased		
INSTALLER INFORMATION		
Installer Name		
Address		
Telephone Number		
Email		
APPLIANCE INFORMATION		
Date Installed		
Appliance Stock Code		
Appliance Description		
Serial Number		
COMMISSIONING CHECK (Complete & Sign)		
	YES	NO
Does the chimney/flue system meet the appropriate standard?		
Has the chimney/flue system been swept and passed the soundness test?		
Has this appliance passed the flue draught test?		
Please write down the flue draught reading:		
Has this appliance passed the smoke test?		
Has this appliance passed the spillage test?		
Have you explained how to operate the appliance and explained the controls?		
Signature:	Print Name:	

SERVICE RECORDS

1st Service	
Date of Service	
Date of next Service	
Servicing Company/ Engineer	
Signature	

3rd Service	
Date of Service	
Date of next Service	
Servicing Company/ Engineer	
Signature	

5th Service	
Date of Service	
Date of next Service	
Servicing Company/ Engineer	
Signature	

7th Service	
Date of Service	
Date of next Service	
Servicing Company/ Engineer	
Signature	

9th Service	
Date of Service	
Date of next Service	
Servicing Company/ Engineer	
Signature	

2nd Service	
Date of Service	
Date of next Service	
Servicing Company/ Engineer	
Signature	

4th Service	
Date of Service	
Date of next Service	
Servicing Company/ Engineer	
Signature	

6th Service	
Date of Service	
Date of next Service	
Servicing Company/ Engineer	
Signature	

8th Service	
Date of Service	
Date of next Service	
Servicing Company/ Engineer	
Signature	

10th Service	
Date of Service	
Date of next Service	
Servicing Company/ Engineer	
Signature	

2-year standard warranty

Any appliance bought through the showroom of an authorised Hunter Stoves Group dealership will automatically be covered by our standard 2-year conditional guarantee.

However, this standard 2-year warranty can be extended to a **5 year** or **10-year** conditional warranty dependent on the model type (5 years- Boiler models, 10 years- Room heater and Gas models).

To qualify for this extended warranty option, you need to:

1. Register your purchase online at <https://hunterstovesuk.azurewebsites.net/ProductRegistration>
2. Retain your proof of purchase.

Warranty conditions

For the Standard 2 year or extended 5/10-year warranty to be valid and to remain in force throughout the warranty period the following must have been carried out:

1. The appliance must have been installed by an appropriately qualified engineer (HETAS or Gas-Safe in the UK) in accordance with the manufacturer's instructions and in compliance of any relevant national or local building regulations.
2. The appliance will need to be registered within two months of purchase and the commissioning and installation documentation completed (these need to be kept by the end user).
3. The appliance must be serviced within 12 months of the installation date for the second year of the standard warranty to be valid, and within every 12-month anniversary thereafter to maintain the validity and coverage of any extended warranty. For this purpose, the installation and user instructions, supplied with the appliance, makes a provision for receipts and annual services to be recorded. This is needed in the event of a claim during the warranty period.
4. Only genuine Hunter Stoves spare parts or consumables can be used in the servicing and maintenance of the appliance during any standard or extended warranty period. These can be sourced from your authorised supplier directly or through our website spares portal. www.hunterstoves.co.uk/spares.
5. Any problems or issues giving rise to any claim under the standard or extended warranty must be submitted to the authorised Hunter Stoves Group retailer from whom you originally purchased the appliance. Hunter Stoves Group will then offer appropriate support and help through your original authorised supplier to solve any issues.
6. The standard or extended warranty option is not transferable. It is solely for the benefit of the original purchaser of the appliance. For this purpose, please retain the proof of purchase.

Warranty exclusions

No warranty period is extended to naturally-wearing replaceable consumables and spare parts within the appliance. Such parts include, but are not limited to:

For Solid Fuel Stoves:

Glass and rope/ceramic seals
Door handle assembly
Fire bricks
Baffles/Throat plates
Log retainers, grate supports & catch bars
Grate parts
Ash-pans
Clip-in Boilers

For Gas Stoves:

Gas pilot assemblies
Thermocouples and Oxy pilots
Ceramic log & coal 'fuel -effects'

For both Solid Fuel and Gas Stoves:

The paint or surface covering of the appliance:

1. Damage to the paint surface caused by the appliance being stored in a damp and cold environment is not covered on the warranty.
2. In the course of the initial firings of the appliance the paint or enamel surface may change colour. This is considered to be normal and as such is therefore not covered by the warranty.
3. Damaged caused by over firing, resulting in cracking, bubbling or discolouration to the paint or enamelled surface finish is not covered by the warranty.

Warranty limitations

1. Damage to the appliance due to specific local conditions caused by draft or chimney defects.
2. Damage resulting from installation and use where installation is not in accordance with the manufacturer's instructions or local building and/or safety regulations.
3. Damage or premature wear caused by burning inappropriate fuels such as Bituminous coal, "Petro-Coke" or any other Petroleum based coals. Please visit the HETAS website, www.hetas.co.uk, for a full list of approved fuels which are covered by the warranty. Fuels outside of this list are not covered by the warranty.
4. Damage caused by burning material with high creosote content or any other painted/treated timber.
5. Consequential loss to associated non-Hunter Stoves Group products is not covered under the warranty.
6. Consequential loss relating to decorations, soft furnishings or other household assets is not covered under the warranty.
7. Cost associated with the removal and re-installation of an appliance subject to a warranty claim.

Hunter Stoves Group total liability will only extend to the total purchase price paid for the goods in any warranty claim. Hunter Stoves Group reserve the right to replace, repair or refund to value of goods purchased.

ANY HUNTERS STOVES GROUP PRODUCT PURCHASED VIA AN INTERNET SUPPLIER, OR THROUGH AN UNAUTHORISED STOCKIST WILL ONLY BE SUPPORTED BY THE STATUTORY, 12 MONTH GUARANTEE AND WILL NOT QUALIFY FOR ANY EXTENDED 5 OR 10 YEAR WARRANTY.

The Hunter Stoves Group extended warranty option does not affect your statutory rights.

This revised standard or extended 5 or 10-year warranty option comes into effect on **1st September 2015** and will apply to all appliances sold from that date.

This standard/extended warranty applies to purchases of Hunter Stoves within the United Kingdom and the Republic of Ireland. Purchases in all other countries are subject to the warranty conditions specified by the distributor in those markets.



hunterstoves
GROUP

Hunter Stoves Ltd, 8 Emperor Way, Exeter Business Park, Exeter, Devon, EX1 3QS
www.hunterstoves.co.uk Email: info@hunterstoves.co.uk