

Inset Sønderskoven 8

Multi-Fuel Inset Stove

Installation and Operating Instructions



Inset Sønderskoven 8

Cleanburn, Trevilla Park, Slaughterbridge, Camelford, PL32 9TT

DSEN13229 – Inset Wood Burning Stove

Appliance Mass	116.5kg
Efficiency	75%
Nominal Heat Output	6.0kW
Mean Co Emission (@13% O ₂)	0.18%
Mean Flue Gas Temperature	326°C
Flue Gas Mass Flow	6.1g/sec

Minimum Clearance to Combustible Material

At the sides of the stove	200mm
In front of the stove (to furniture etc)	700mm
Above the stove	275mm

This appliance is not for use in a shared flue

This appliance is suitable for intermittent burning

This stove has been designed and assembled so that it may be used to burn wood logs in a Smoke Control Area.

Find out if you are in a Smoke Control Area by contacting your Local Authority.

The Inset Sønderskoven 8 has been fitted with a permanent stop that prevents closure of the secondary air slider. Removal of this will lead to the appliance potentially causing smoke emissions. Without the permanent stop in place the appliance is not an exempt appliance and so may leave the householder liable for a fine up to £1000.

General Guidance

It is important that your stove is correctly installed as Cleanburn cannot accept responsibility for any fault arising through incorrect use or installation. These instructions cover the basic principles to ensure satisfactory installation of the stove, although detail may need slight modification to suit particular local site conditions.

The installation must comply with current Building Regulations, national and European standards, Local Authority byelaws and other specifications or regulations as they affect the installation of the stove. The Building Regulations requirements may also be met by adopting the relevant recommendations in the current issues of British Standards BS 8303 and BS EN 15287-1.

COMPETENT PERSONS SCHEME

Cleanburn recommend that this stove is installed by a member of an accredited competent persons scheme e.g. HETAS.

If the installer is not a member of a competent person's scheme, it is a legal requirement to notify your local building control body in advance of any work starting.

CO ALARMS

Building regulations require that whenever a new or replacement fixed solid fuel or wood/biomass appliance is installed in a dwelling, a carbon monoxide alarm must be fitted in the same room as the appliance.

Further guidance on the installation of the carbon monoxide alarm is available in BS EN 50292:2002 and from the alarm manufacturer's instructions.

Provision of an alarm must not be considered a substitute for either installing the appliance correctly or ensuring regular servicing and maintenance of the appliance and chimney system.

HEALTH AND SAFETY PRECAUTIONS

Special care must be taken when installing the stove such that the requirements of the Health and Safety at Work Act are met.

HANDLING

Adequate facilities must be available for loading, unloading and site handling.

FIRE CEMENT

Some types of fire cement are caustic and should not be allowed to come into contact with the skin. In case of contact, wash immediately with plenty of water.

ASBESTOS

This stove contains no asbestos. If there is a possibility of disturbing any asbestos in the course of installation then please seek specialist guidance and use appropriate protective equipment.

METAL PARTS

When installing or servicing this stove, care should be taken to avoid the possibility of personal injury.

MODIFICATION

No unauthorized modification of this appliance should be carried out.

Safety

WARNING – This appliance will be hot when in operation and due care should be taken. The supplied gloves may be used to open the door and operate the air controls.

AEROSOLS

Do not use an aerosol spray on or near the stove when it is alight.

FIREGUARDS

Always use a fireguard in the presence of children, the elderly or the infirm. The fireguard should be manufactured in accordance with BS8423 – Fireguards for use with solid fuel appliances.

DO NOT OVER-FIRE

It is possible to fire the stove beyond its design capacity. This could damage the stove so watch for signs of over-firing. If any part of the stove starts to glow red, the stove is in an over-fire situation and the controls should be adjusted accordingly. Never leave the stove unattended for long periods without first adjusting the controls to a safe setting. Careful air supply control should be exercised at all times.

FUME EMISSION

WARNING NOTE

Properly installed, operated and maintained, this appliance will not emit fumes into the dwelling. The appliance door(s) must be kept closed at all times, except for when de-ashing and refueling, during which occasional fumes may occur. However, Persistent fume emission is potentially dangerous and must not be tolerated.

If fume emission does persist, then the following immediate action should be taken: -

1. Open doors and windows to ventilate the room and then leave the premises.
2. Let the fire go out.
3. Check for flue or chimney blockage and clean if required.
4. Do not attempt to re-light the fire until the cause of the fume emission has been identified and corrected. If necessary, seek expert advice.

The most common cause of fume emission is flue way or chimney blockage. For your own safety these must be kept clean at all times.

Adverse weather – In a small number of installations, occasional local weather conditions (e.g. wind from a particular direction) may cause downdraught in the flue and cause the stove to emit fumes. In these circumstances, the stove should not be used. A professional flue installer will be able to advise on solutions to this problem (e.g. anti-downdraught cowl).

CO ALARM

Your installer should have fitted a CO alarm in the same room as the appliance. If the alarm sounds unexpectedly, follow the instructions given under “Warning Note” above.

DO NOT FIT AN EXTRACTOR FAN IN THE SAME ROOM AS THIS APPLIANCE.

IN THE EVENT OF A CHIMNEY FIRE -

- Raise the alarm
- Call the Fire Brigade
- Close appliance air controls
- Move furniture, ornaments etc away

- Place a fireguard in front of stove
- Check the chimney breast for signs of excessive heat.

If the wall is becoming excessively hot, move furniture away. Ensure the Fire Brigade can gain access to your roof space in order to check for fire spread.

Installation

APPLIANCE DIMENSIONS

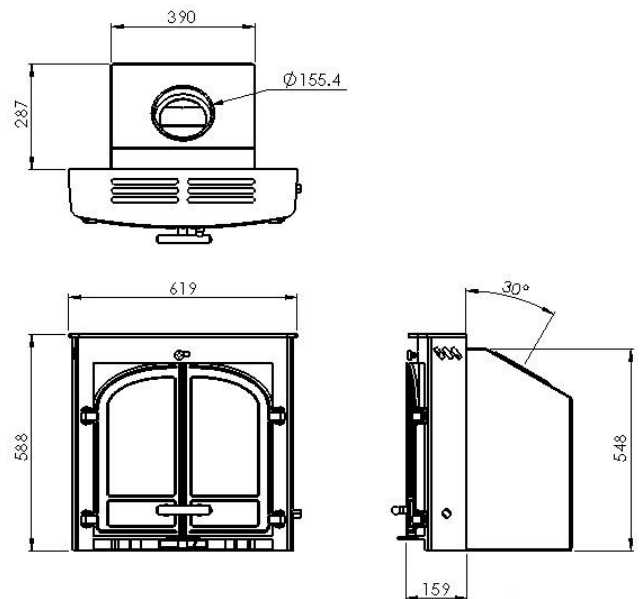

FLUE OUTLET POSITION

The flue outlet angle is 30° . The effective centre dimension is shown below.

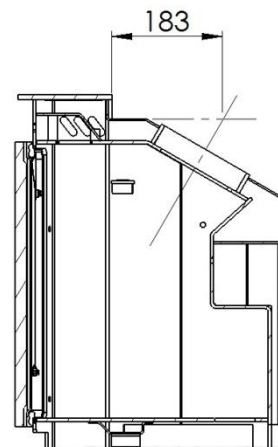

AIR SUPPLY

The room or space containing this appliance should have purpose provided ventilation (where necessary) in accordance with Building Regulations.

Due consideration should be given to air requirements for any other appliance in the same room or space.

Any air opening must be kept clear from blockage or obstruction.

APPLIANCE OPENING

FLUE CONNECTION - All inset installations must have a 'Throat Forming Lintel', if a 'Builders Opening Lintel' is present then this will have to be modified for these units to be fitted.

This stove must be fitted on a hearth or base with adequate load-bearing capacity. The opening into which this stove is fitted should be constructed wholly from non-combustible materials. The dimensions of the opening should be **at least** those shown in the diagram.

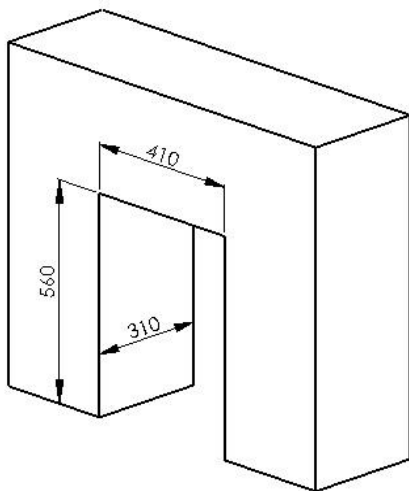

This appliance will fit into a standard 16" fireplace opening if the clay fire back is removed.

Any non-combustible walls within 50mm of this appliance should be at least 200mm thick and should extend at least 300mm above the top of the appliance and at least 1.2 metres above the hearth. Any walls more than 50mm from the appliance may be reduced to a thickness of 75mm. Ensure the inter-

connecting flue pipe also has adequate clearances to combustible materials.

The walls surrounding the stove will become hot and should therefore be finished in a heat resistant plaster.

Do not hang pictures, plasma screen televisions or ornaments above the stove, as these could be damaged and could potentially create a fire hazard.

Please check the suitability of any fireplace/surround for closed solid fuel appliances before installation. Cleanburn cannot be held responsible for any fault arising through incorrect use or installation. Fire surround back panels suitable for solid fuel are usually in three sections and slabbed. Many fire surrounds are suitable only for use with gas and electric fires and therefore not suitable for solid fuel.

HEARTH REQUIREMENTS

A constructional hearth with a minimum thickness of 125mm should be provided. This constructional hearth should extend to at least 300mm in front of the stove and 150mm at the sides.

The constructional hearth should be made of solid non-combustible material and can include any solid non-combustible floor. The boundary of the hearth must be clearly marked. This can be done by adding a super-imposed hearth on top of the constructional hearth – e.g. a slate slab on top of a solid concrete floor.

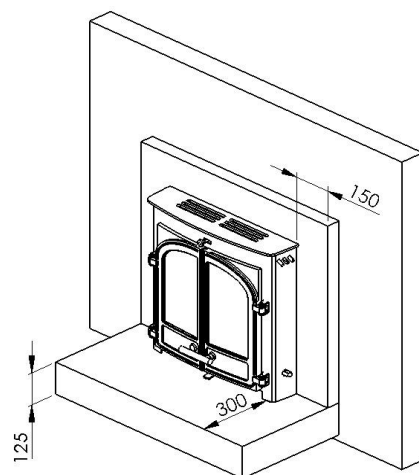

FLUE REQUIREMENTS

The flue serving this appliance must be dry, free from cracks and obstructions and be in

accordance with the designations shown in Table 1.

The diameter of the flue should not be less than 150mm and not more than 200mm.

If these requirements are not met the chimney should be lined by a suitable method.

If there is no existing chimney then either a prefabricated block chimney in accordance with Building Regulations Approved Document J or a twin-walled insulated stainless steel flue to BS EN 1856 can be used. These chimneys must be fitted in accordance with the manufacturer's instructions and Building Regulations.

<i>Flue Type</i>	<i>Minimum Designation</i>
Masonry or flue block flue with liner	T400 N2 D3 G (BS EN 1443:2003)
Clay Flue Blocks	FB1 N2 (BS EN 1806:2006)
Clay/Ceramic Liners	B1 N2 (BS EN 1457:2009)
Concrete Liners	B2 (BS EN 1857:2003)
Factory Made Metal Chimney	T400 N2 D3 G (BS EN 1856-1:2003)

Table 1 – Minimum Flue Designations

The chimney/flue should have a vertical height of at least 4.5 meters and should terminate in accordance with Table 2.

If the chimney is believed to have previously served an open fire installation, it is possible that the higher flue gas temperature from the stove may loosen deposits that were previously firmly adhered, with the consequent risk of flue blockage. It is therefore recommended that the chimney is swept a second time within a month of regular use after installation.

If you have any doubts about the suitability of your chimney, consult your local dealer/stockist.

Both the chimney and flue pipe must be accessible for cleaning and if ANY part of the

chimney cannot be reached through the stove (with baffle removed), a soot door must be fitted in a suitable position.

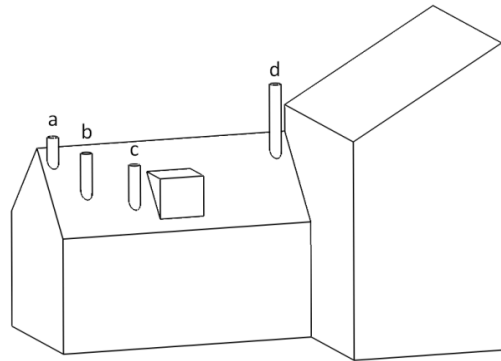

<i>Terminal</i>	<i>Position</i>	<i>Clearances to Flue Outlet</i>
a	At or within 600mm of the ridge	At least 600mm above the ridge
b	Elsewhere on a roof (whether pitched or flat)	At least 2300mm horizontally from the nearest point on the weather surface and: At least 1000mm above the highest point of intersection of the chimney and the weather surface or At least as high as the ridge
c	Below (on a pitched roof) or within 2300mm horizontally to an openable roof light, dormer window or other opening.	At least 1000mm above the top of the opening.
d	Within 2300mm of an adjoining or adjacent building, whether or not beyond the boundary.	At least 600mm above any part of the adjacent building within 2300mm

Table 2 – Flue Terminal Positions

FLUE DRAUGHT

If the draught exceeds the recommended maximum, a draught stabiliser must be fitted so that the rate of burning can be controlled and to prevent over firing.

If the reading is less than the recommended minimum then the performance of the appliance will be compromised.

The flue draught should be checked under fire at high output.

***Minimum Draught – 1.2mm Water Gauge
Maximum Draught – 2.5mm Water Gauge***

CLEARANCES TO COMBUSTIBLE MATERIALS

Excluding some fire surround installations (see below) there should be no combustible material within 200mm of either side of the stove or 275mm above.

No combustible furniture should be placed any closer than 700mm from the front of the stove.

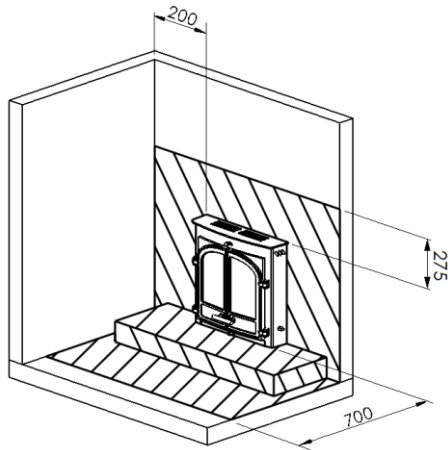

FIRE SURROUNDS

Please check the suitability of any fireplace/surround for closed solid fuel appliances before installation.

Cleanburn cannot be held responsible for any fault arising through incorrect use or installation.

Fire surround back panels suitable for solid fuel are usually in three sections and slabbed. Many fire surrounds are suitable only for use with gas and electric fires and therefore not suitable for solid fuel.

A combustible fire surround with a depth of up to 100mm requires a minimum clearance of 100mm from the side of the stove. For combustible fire surrounds with a depth in excess of 100mm this clearance must be increased to 200mm.

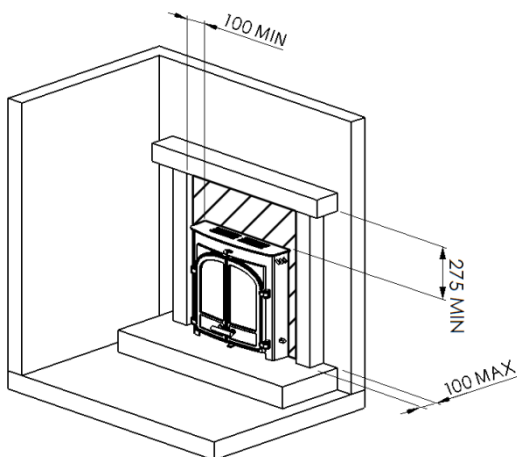

REMOVING INTERNAL COMPONENTS

All internal components must be removed prior to fitting the stove. This will make handling the stove easier; allow access to fixings and the flue outlet; as well as protect the internal components from damage during the installation process.

1. Open the door(s) and remove the ash pan.

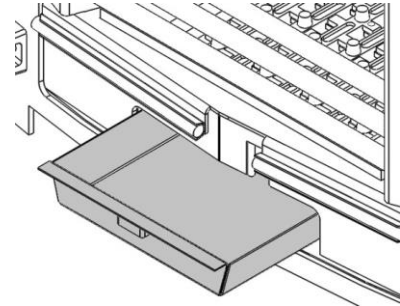

2. Remove the fuel retainers by turning them towards you until the pins at the ends of them align with the cut-outs in the fuel retainer supports and sliding them out.

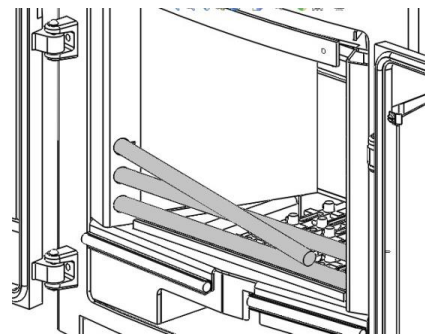

3. Remove the fuel retainer supports by lifting them free from the slots in the catch bar and swinging the bottom ends out of the stove.

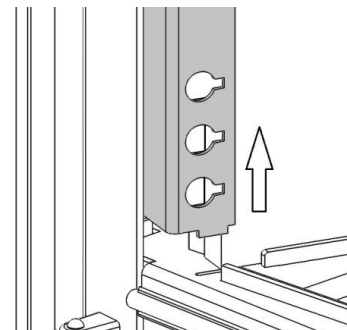

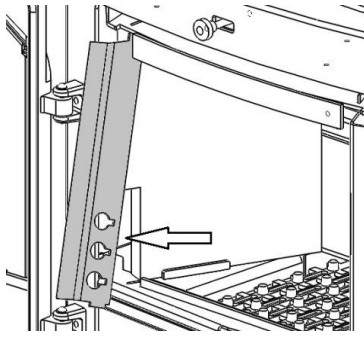

4. Slide the side bricks out.

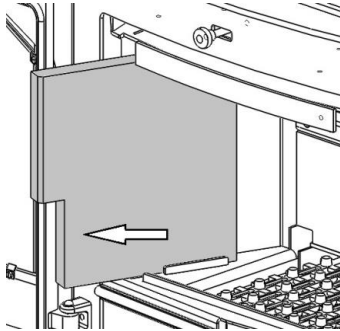

5. Remove the rear bricks.

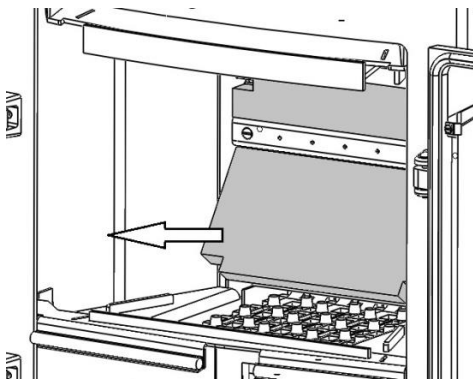

6. Remove the lower rear brick support using the finger hole provided to lift it from its slots.

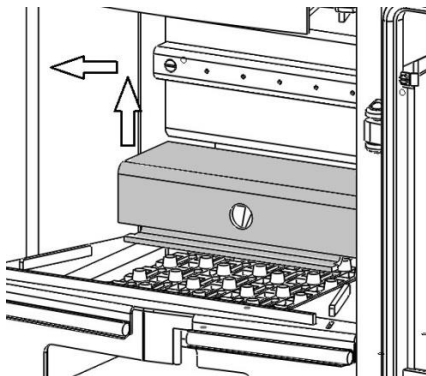

7. Cut the cable ties and remove the baffle by rolling it up over the baffle supports and out of the stove.

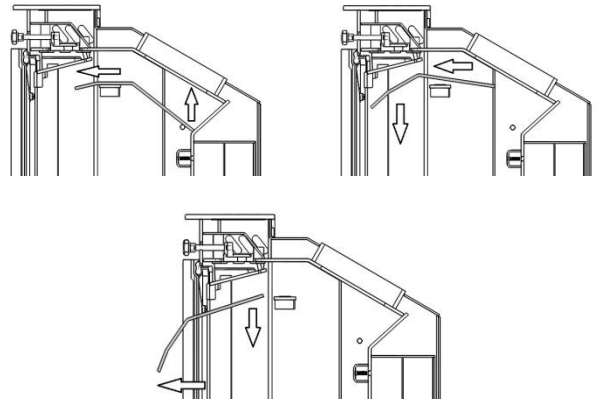

8. Remove the grate bars, starting with the high bars.

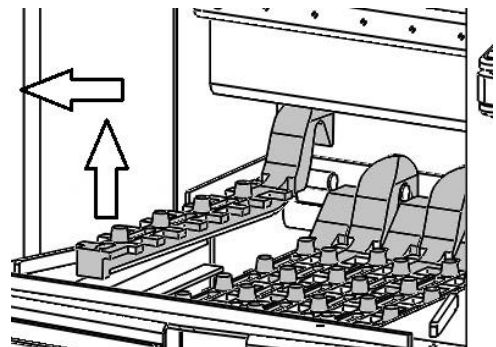
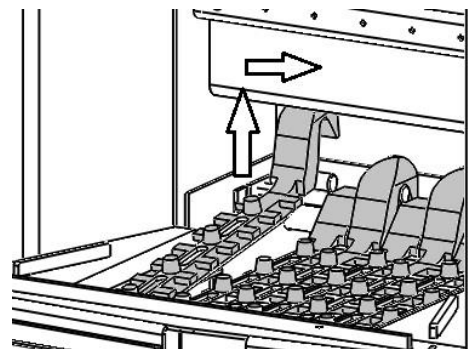

9. Remove the firebox side plates.

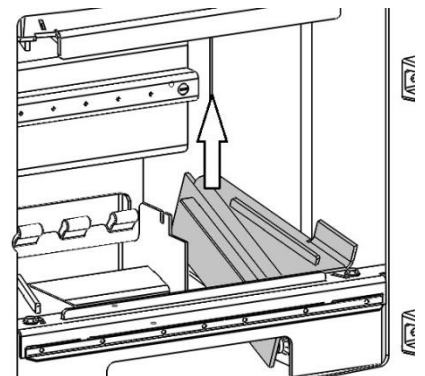

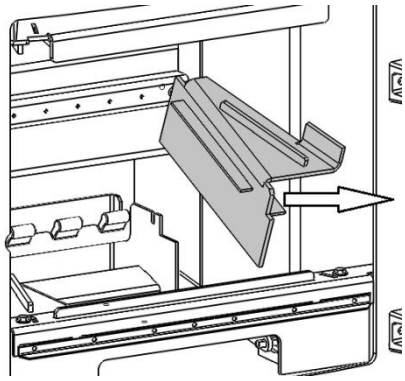

10. Remove the catch bar/front plate.

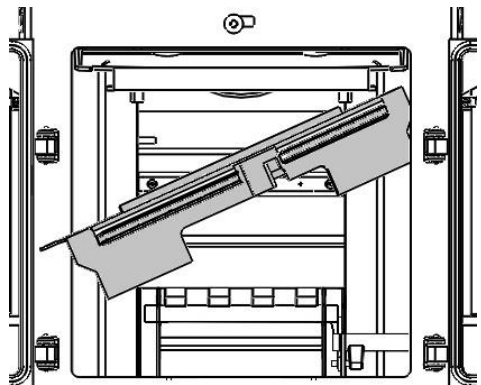
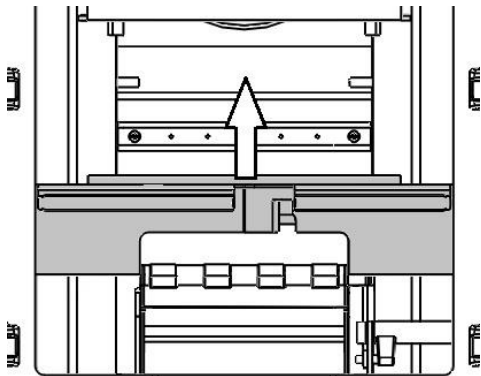

11. Detach the cam bar linkage arm from the front cam bar, rotate the cam bar and lift it out.

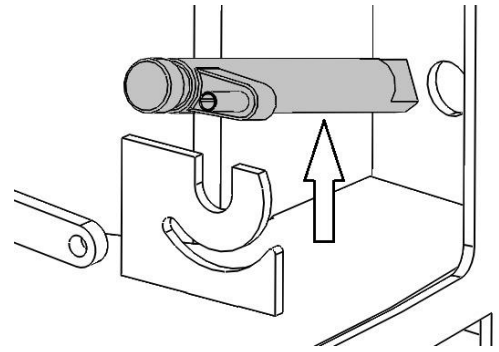
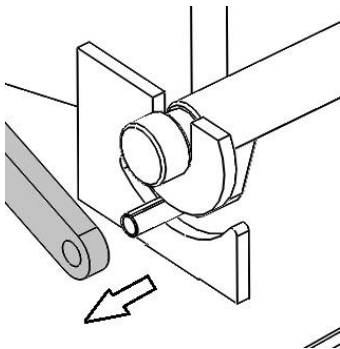

12. Lift out the rear cam bar along with the cam bar linkage arm.

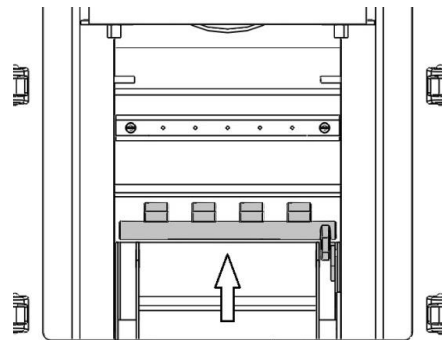

13. Lift out the primary air duct.

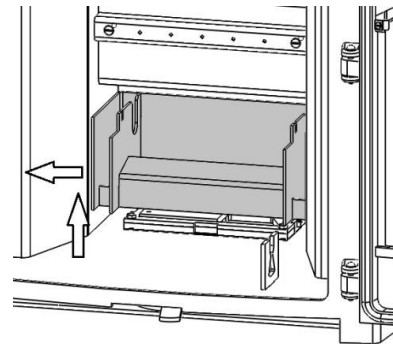

14. Lift out the primary air valve slider.

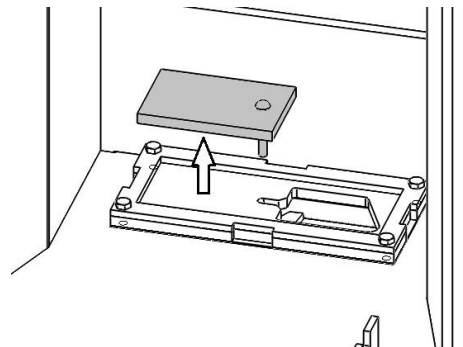

15. Undo the four M6 x 25mm screws and remove the primary air valve and gasket.

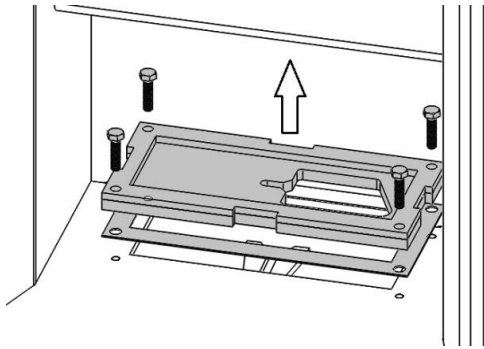

16. Slide the primary air valve control arm all the way to the left.

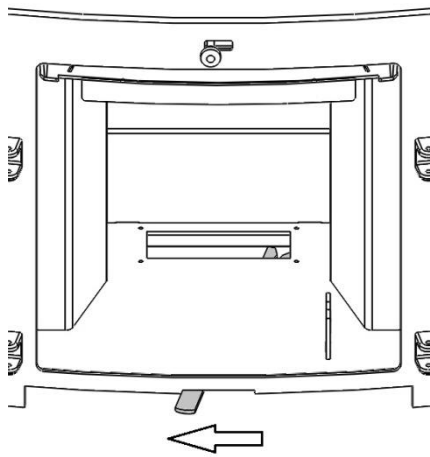

INSTALLATION INSTRUCTIONS

1. Using the diagram below, mark and drill a hole using a 6mm drill bit to a depth of 70mm.

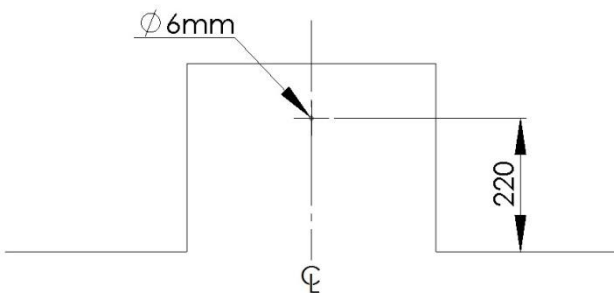

2. Slide the stove into position, ensuring that the sealing rope is compressed against the fireplace and fix using the supplied fixing screw (with washer).

Any voids around the stove must be In-filled with vermiculite concrete with a recommended mix of six parts vermiculite to one part Ordinary Portland Cement. This may be carried out once the flue has been fitted provided a suitable access hole for backfilling

is made in the chimney breast (see section on connecting to a masonry chimney). Sufficient water should be added so that when a handful of the mixture is squeezed no more than one or two drops of water are released.

FLUE CONNECTION

If connecting to a stainless steel liner, a liner clamp (HHN07/ARRT/003) will need to be used.

The clamp should be connected to the liner by a proprietary flexible liner to single wall flue adaptor using the three fixing holes in the clamp socket and those provided in the flue adaptor.

The clamp can be attached to the bottom of the liner without the appliance fitted. Apply fire cement to the inside of the stove's flue collar. The stove can then be set back in the recess and the liner clamped onto the stove by passing the clamp fixing bolts through the flue outlet and securing in place using the clamping flange and nuts and washers provided. Make sure all joints are sealed with fire cement.

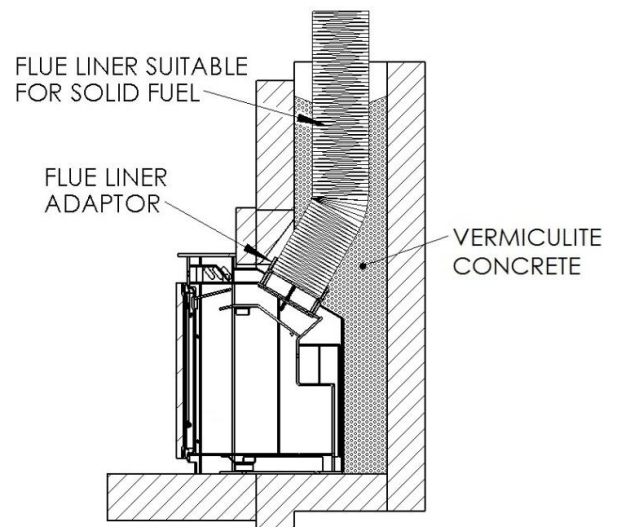

If connecting to an existing masonry chimney it is recommended that a flue forming pipe (short length of flue pipe) is used and the void between the flue forming pipe and the chimney is filled with vermiculite concrete.

A suitable access hole will need to be made in the chimney breast to allow the back filling to be carried out and then filled and sealed once the installation is complete.

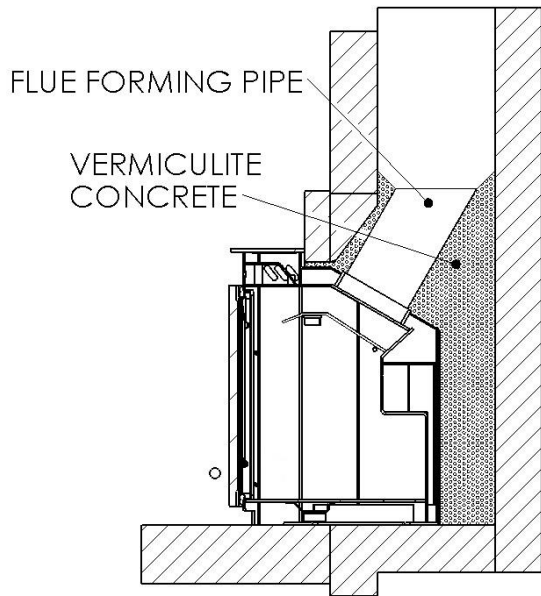

Alternatively a connection can be made using a register plate although it will be necessary to allow access for fitting the flue pipe to the register plate, infilling with vermiculite concrete and sealing all joints.

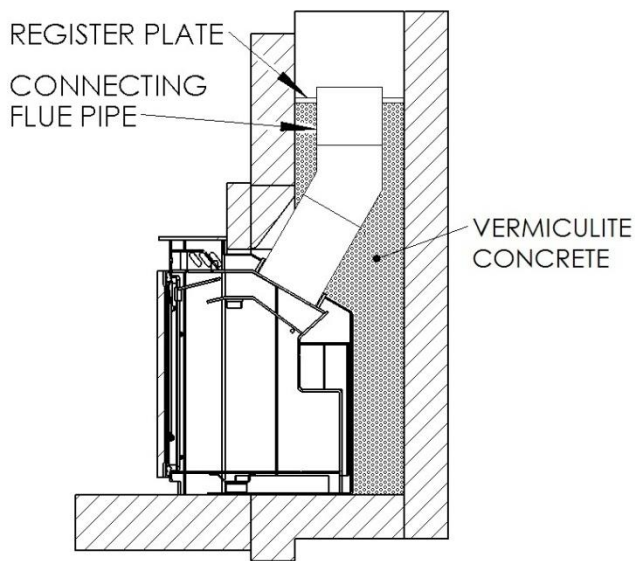

RE-ASSEMBLING THE STOVE

Refit all the internal parts by following the 'removing internal components' instructions in reverse order.

Ensure that the firebox side plates are refitted using the following procedure.

Insert the side plate so that the front end of it locates under the front plate/catch bar as shown.

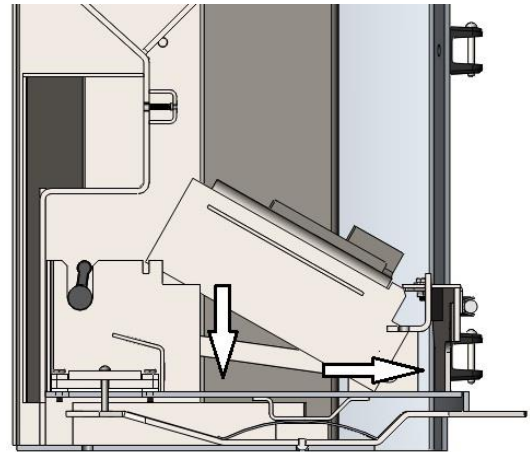

Ensure that the back end of the side plate is outside the rear grate support as shown.

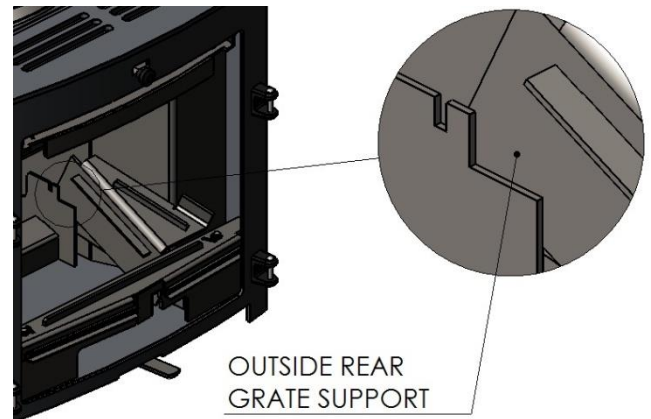

Lower the side plate into position so that the top surface of it is flush with that of the front plate/catch bar as shown.

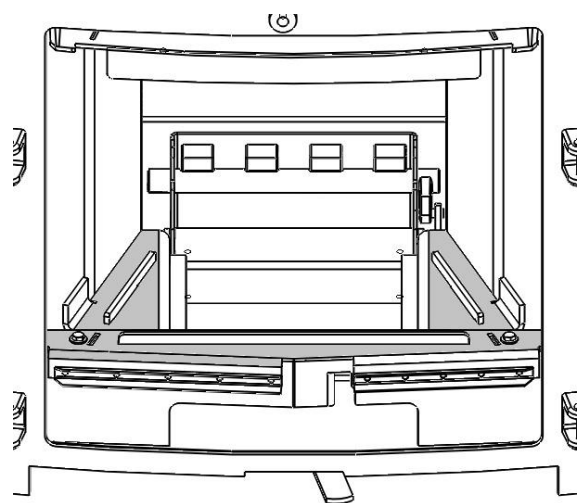

COMMISSIONING & HANDOVER

Upon completion of the installation allow a suitable period of time for any fire cement and mortar to dry out. A small fire may then be lit and the installation checked to ensure the smoke and fumes are drawn up the flue and emitted safely to atmosphere. The stove should not be run at full output for at least 24 hours.

Read the Operating Instructions before lighting the stove for the first time.

Leave the instructions and operating tool(s) with the customer and advise them on -

- Correct use of the appliance
- The recommended fuel
- Action to be taken should smoke or fumes be emitted from the stove or installation.
- The use of a fireguard when the stove is used in the presence of children or the infirm.

Operating Instructions

Read the 'General Guidance' Section at the start of these instructions before operating your stove for the first time.

Allow sufficient clearance between the stove and pictures, plasma screen televisions or ornaments etc, as these could be damaged and could potentially create a fire hazard (For more information read the 'Clearance Distances to Combustibles' section of the installation instructions).

WARNING – This appliance will be hot when in operation and due care should be taken. The supplied operating tool or gloves may be used to open the door and operate the air controls.

Operation with the door(s) open can cause excess smoke. This appliance must **not** be operated with the door(s) open.

AEROSOLS

Do not use an aerosol spray on or near the stove when it is alight.

AIR CONTROLS

Installed, operated and maintained correctly, this stove will burn cleanly and efficiently. Therefore, to avoid the disappointment of poor performance,

please familiarize yourself with the controls and their recommended settings before use.

PRIMARY AIR

The slider at the bottom of the stove controls the primary air. This provides a conventional air draught to the bed of the fire. The control is open when the slider is fully to the right.

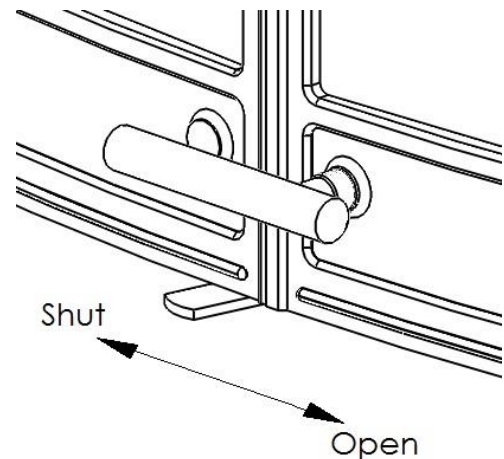

SECONDARY & TERTIARY AIR

Secondary air is controlled via the slider above the door(s) (slide right to open), it is this "Airwash" that keeps a clean and uninterrupted view of the fire.

Tertiary air is fixed and enters the stove through the holes at the back of the firebox. It aids in good secondary combustion and reduces emissions into the chimney and environment.

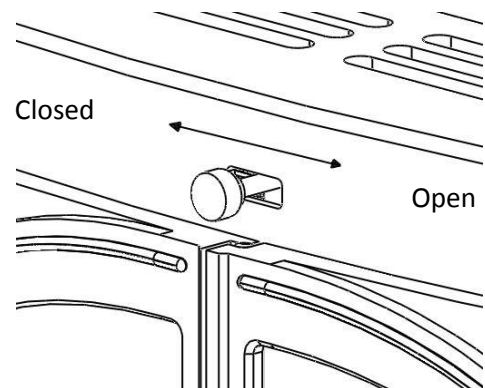

Warning! - This Appliance will be hot when in operation and due care should be taken.

We advise that suitable gloves are used when operating the Primary and Secondary air controls, and when opening the door.

RIDDLING GRATE

Your Cleanburn stove is fitted with a locomotive type grate. So that de-ashing can be carried out cleanly and easily, it is riddled from the outside of the stove with the doors closed.

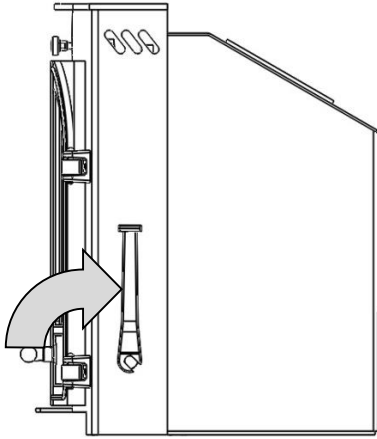

NOTES ON WOOD BURNING

Wood can be stacked in the stove, but care must be taken that logs do not touch the baffle. Overloading the stove can cause excess smoke to be emitted.

Pull the operating tool down and towards you. When left in this position, air is restricted through the bed of the fire providing a solid base to build up a bed of ash.

If there is insufficient burning material in the fire bed to light a new fuel charge, excessive smoke emission can occur.

Refuelling must be carried out with a sufficient quantity of glowing embers and ash, so that the new fuel charge will ignite quickly. If there are too few embers, add some kindling to prevent excessive smoke.

LIGHTING

We recommend that you have two or three small fires before you operate your stove to its maximum heat output.

This is to allow the paint to cure in steadily and to give a long service life of the paint finish.

During this curing in process you may notice an unpleasant smell. It is non-toxic, but for your comfort we would suggest that during this period you leave all doors and windows open.

To light the stove open the primary and secondary air controls by pushing both levers fully to the right. Light one or two firelighters placed centrally on the grate, allowing the flames to become established before placing several pieces of small dry kindling in a criss-cross fashion above the firelighters, taking care not to smother the fire. Close the stove door. Once the kindling is well alight open the door and build the fire by gradually adding slightly larger pieces of wood, closing the door afterwards.

Once you have a good fire established across the grate bed, further fuel can be added as required and the air controls set to the correct position (see 'Notes on Wood burning').

Should the fire fail to light correctly open the door and use a poker to spread the fuel across the grate. Close the door and allow the fuel and stove to cool before attempting to relight the fire.

N.B. Leaving the air controls in the closed position, adding too much fuel or using wood that is wet or too large will prevent the fire from establishing correctly and may result in smoke emission from the stove.

REFUELLING

With a 2.4kg load of wood, the stove will need to be refuelled approximately once every 1.1 hours.

The maximum recommended log length is 200mm (8") and the maximum recommended log diameter is 100mm (4").

REDUCED COMBUSTION

In order to shut down the stove, reduce the primary and secondary air by sliding both controls to the left.

If the controls are left in this position, the fire will be starved of air and will die down.

If you want to revive the fire it is recommended that the primary air control is opened first, and then the secondary air control.

Warning! - The stove will remain **hot** for a considerable time after the fire has been extinguished.

THE CLEAN AIR ACT 1993 AND SMOKE CONTROL AREAS

Under the Clean Air Act 1993 local authorities may declare the whole or part of the district of the authority to be a smoke control area. It is an offence to emit smoke from a chimney of a building, from a furnace or from any fixed boiler if located in a designated smoke control area. It is also an offence to acquire an "unauthorised fuel" for use within a smoke control area unless it is used in an "exempt" appliance ("exempted" from the controls which generally apply in the smoke control area).

The Secretary of State for Environment, Food and Rural Affairs has powers under the Act to authorise smokeless fuels or exempt appliances for use in smoke control areas in England. In Scotland and Wales this power rests with Ministers in the devolved administrations for those countries. Separate legislation, the Clean Air (Northern Ireland) Order 1981, applies in Northern Ireland. Therefore it is a requirement that fuels burnt or obtained for use in smoke control areas have been "authorised" in Regulations and that appliances used to burn solid fuel in those areas (other than "authorised" fuels) have been exempted by an Order made and signed by the Secretary of State or Minister in the devolved administrations.

Further information on the requirements of the Clean Air Act can be found here:

<http://smokecontrol.defra.gov.uk/>

Your local authority is responsible for implementing the Clean Air Act 1993 including designation and supervision of smoke control areas and you can contact them for details of Clean Air Act requirements

The Inset Sønderskoven 8 has been recommended as suitable for use in Smoke Control Areas when burning wood logs.

RECOMMENDED FUELS

Cleanburn recommend that wood logs are burnt in this appliance.

The maximum recommended log length is 200mm (8") and the maximum recommended log diameter is 100mm (4").

Burn only dry, well-seasoned wood, which should have been cut, split and stacked for at least 12 months, with free air movement around the sides of the stack to enable it to dry out.

Burning wet or unseasoned wood will create excess smoke emissions, tar deposits in the stove and chimney and will not produce a satisfactory heat output.

Only authorised smokeless fuels may be used in smoke control areas.

Warning! - Petroleum coke fuels or household waste must not be burnt on this appliance.

This appliance should not be used as an incinerator. No liquid fuels should be burnt on this appliance.

Should any difficulties arise over fuel quality or suitability, consult your local approved coal merchant or:

HETAS Ltd – Telephone 01242 673257 –
www.hetas.co.uk

Solid Fuel Association – Telephone 0800 600 000 –
www.solidfuel.co.uk

General Maintenance

Important! –In order to ensure continued compliance with current Building Regulations and Local Authority Byelaws, this appliance requires regular maintenance of the following – N.B. Refer to the 'Removing Internal Components' section of the installation instructions for details on how to remove each component.

AS NECESSARY

Baffle- This should be removed and cleaned at least once a month to prevent any build up of soot or fly ash that could lead to blocked flue ways and dangerous fume emission.

If the baffle is removed the chimney/flue way can be swept through the appliance.

Stove body – the stove is finished with a heat resistant paint and this can be cleaned with a soft brush. Do not clean the stove whilst it is hot; wait until it has cooled down. The finish can be renovated with proprietary stove paint.

Glass Panel(s) - Clean the glass panel when cool with proprietary glass cleaner.

Highly abrasive substances should be avoided as these can scratch the glass and make subsequent cleaning more difficult.

Wet logs on heated glass, a badly aimed poker or heavy slamming of the door could crack the glass panel.

The glass will not fracture from heat.

Firebricks- In normal use, these can last for many years. It is possible however, to crack them if logs are continually jammed against them or if they are frequently struck with a poker.

Check periodically for seriously cracked bricks, which can be replaced with new, available from your dealer.

Door Catch- The door catch may require adjustment to maintain the door seal. To adjust the catch, follow the appropriate procedure below;

- Loosen the M6 grub screw.
- Rotate the catch shaft one complete turn to achieve the correct door operation.
- Tighten the grub screw.

Rope- Check the rope around the door. If rope is becoming detached, use Cleanburn rope glue to reattach it. If the rope is in a poor condition, a replacement rope kit may be ordered from the Cleanburn stoves spares range.

Chimney & Flue Ways- It is important that the chimney, flue ways and any connecting flue pipe are swept regularly. This means at least once a year for smokeless fuels and at least twice a year for wood and other fuels.

The baffle will need to be removed from its supports in order to sweep the chimney (see 'Removing internal components' instructions).

Only wire-centred sweeps' brushes fitted with a guide wheel should be used.

If it is not possible to sweep all parts of the chimney through the appliance, ensure there is adequate access to cleaning doors.

Periods of Prolonged Non-Use - If the stove is to be left unused for a prolonged period of time then it should be given a thorough clean to remove ash and unburned fuel residues. To enable a good flow of air through the appliance to reduce condensation and subsequent damage, leave the air controls fully open.

If the appliance has been unused for a long period of time, such as during the spring and summer months, a competent person should check the chimney for potential obstructions before lighting the stove.

Gaskets- all gaskets used on this appliance are produced from a heat resistant material called Manniglas. The glass gasket will have to be replaced when a new piece of glass is fitted as the gaskets become brittle after firing the stove. Over time you may find that the gasket changes colour. This is due to reduction in the pigment used in the manufacture of the product and no cause for concern.

Trouble Shooting

FIRE WILL NOT BURN

Check that –

- Chimneys and flue ways are clear.
- A suitable fuel is being used.
- There is an adequate air supply into the room.
- An extractor fan is not fitted in the same room as the stove.
- Flue draught is above minimum level (see installation instructions).

FIRE BLAZING OUT OF CONTROL

Check that –

- The door is tightly closed.
- The air controls are in the closed position.
- A suitable fuel is being used.
- The glass is not loose.
- The door rope seal is in good condition.
- Flue draught is below maximum level (see installation instructions)

Spares Information

Single Door Spares

Door Glass
(HCE09/102)

Glass Gasket
(HCE09/101)

Door Handle Assembly
(HCE09/ARRT/043S)

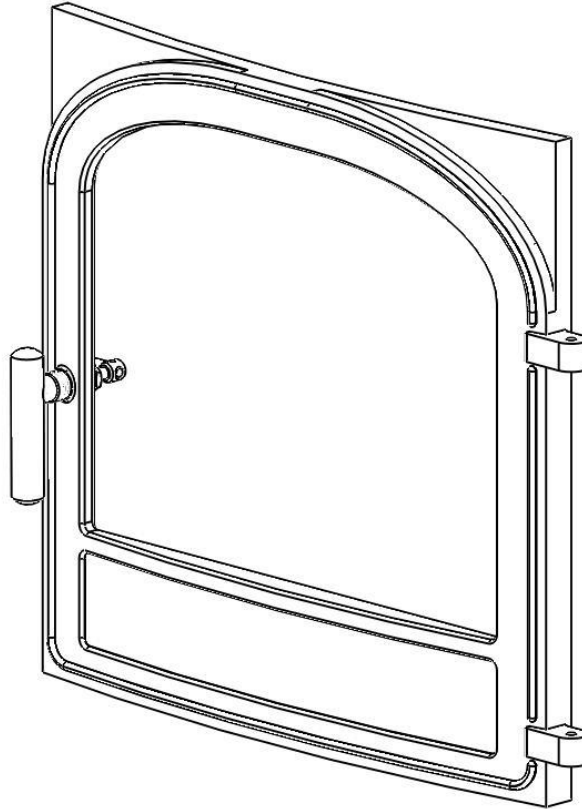

Single Door
(HCN09/008)

Glass Clip
(HHR08/046)

Glass Clip Screw
(FSJM05008SS)

Rope Sealing Kit
(SCPCB900SDRSK-REVC)

Double Door Spares

Left Hand Door
(HCN09/010)

Door Glass
(HCN09/031)

Glass Gasket
(HCN09/030)

Glass Clip
(HHR08/046)

Glass Clip Screw
(FSJM05008SS)

Rope Sealing Kit
(SCPCB900DDRSK)

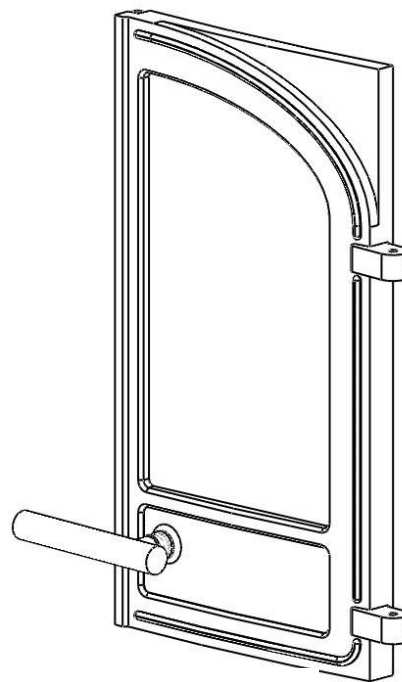
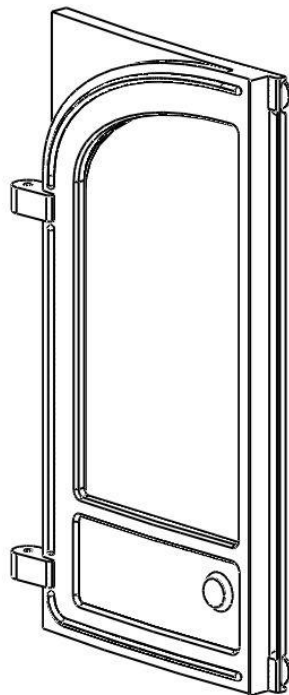

Right Hand Door
(HCN09/009)

Door Glass
(HCN09/031)

Glass Gasket
(HCN09/030)

Glass Clip
(HHR08/046)

Glass Clip Screw
(FSJM05008SS)

Door Handle Assembly
(HCE09/ARRT/042S)

Spares Information

Single Door Body Spares

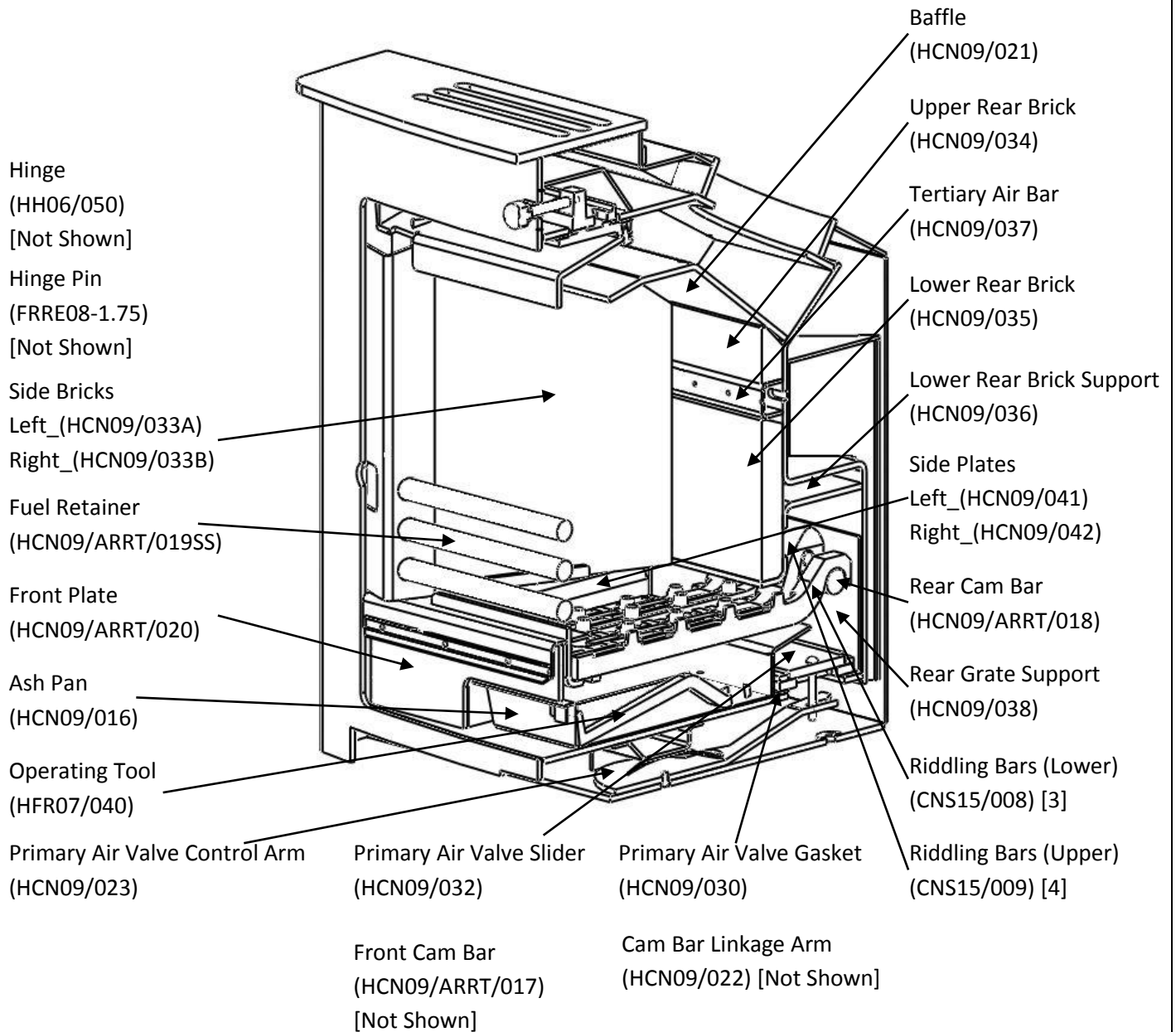

Spares Information

Double Door Body Spares

