



DERWENT  
CONSORT 4  
CONSORT 5  
COMPACT 5  
5 SLIMLINE  
CONSORT 7  
9 SLIMLINE  
CONSORT 9  
CONSORT 15  
MULTIFUEL AND WOOD CE VII MODELS

Instructions for:  
Installation/Operating/Maintenance/Serviceing  
JINCNSDA REV B 06/06/2019

## STOVE MODELS



**DERWENT**  
CVSDR05FM



**CONSORT 4**  
CVCN04FM/CVCN04FW



**CONSORT 5**  
CVSCS05FM/CVSCS05FW



**CONSORT 5 COMPACT**  
CVSCNC05FM/CVSCNC05FW



**CONSORT 5 SLIMLINE**  
CVCNS05FM/CVSCNS05FM  
CVCNS05FW/CVSCNS05FW



**CONSORT 7**  
CVCN07FM/CVSCN07FM  
CVCN07FW/CVSCN07FW



**CONSORT 9 SLIMLINE**  
CVCNS09FM/CVSCNS09FM  
CVCNS09FW/CVSCNS09FW



**CONSORT 9**  
CVCN09FM/CVSCN09FM  
CVCN09FW/CVSCN09FW



**CONSORT 15**  
CVCN15FM/CVSCN15FM  
CVCN15FW/CVSCN15FW





Welcome to the Hunter Stoves family and thank you for purchasing a Parkray Consort stove. This stove was designed and built to be a high-performance heating appliance, and we hope it will bring you great enjoyment. The natural environment is important to us, so our stoves are manufactured to provide you with a clean and efficient burn that will keep you warm through cold winter nights.

CONTENTS INDEX:

STOVE MODELS.....	2
TECHNICAL SPECIFICATION.....	4/5
IMPORTANT INFORMATION.....	6/7
SAFETY.....	7
REMOVE INTERNAL COMPONENTS.....	8/9
APPLIANCE DIMENSIONS.....	10-12
PRE INSTALLATION REQUIRMENTS.....	13
LEGAL REQUIREMENTS.....	14
CLEARANCES.....	15/16
COMMISSIONING AND HANDOVER.....	16/17
OPERATING INSTRUCTIONS.....	17-21
MAINTENANCE & SERVICING.....	21/22
TROUBLESHOOTING.....	23/24
SPARES.....	25-36
INSTALLATION & COMMISSIONING CHECK LIST.....	37
SERVICE RECORDS.....	38
FULL WARRANTY INFORMATION.....	39/40



# Technical Specification

GENERAL	 		DERWENT	CONSORT 4	CONSORT 5 COPMACT	CONSORT 5	CONSORT 5 SLIMLINE
	Energy Efficiency Class		A	A	A	A	A
	Nominal Heat Output	Wood	4.8kW	4.7kW	4.7kW	4.0kW	4.4kW
		Smokeless Fuel	NA	3.0kW	NA	NA	NA
	Energy Efficiency		102	97	101	104	98
	Efficiency	Wood	76.8%	72.8%	76.0%	78.0%	74.1%
	Efficiency	Smokeless Fuel	NA	66.7%	NA	NA	NA
	Mean CO (@13% O <sub>2</sub> )	Wood	0.43%	0.27%	0.30%	0.44%	0.32%
	Mean CO (@13% O <sub>2</sub> )	Smokeless Fuel	NA	0.54%	NA	NA	NA
	Appliance Mass		62kg	64kg	95kg	88kg	88kg
	Recommended Fuels	Wood	Seasoned Wood (less than 20% moisture content)				
	Smokeless Fuel	Anthracite or a manufactured briquette smokeless fuel which is suitable for closed door appliances.					
Log Length		258mm	280mm	330mm	280mm	400mm	
FLUES	Mean Flue Gas Temperature	Wood	271°C	270°C	269°C	246°C	268°C
	Mean Flue Gas Temperature	Smokeless Fuel	NA	332°C	NA	NA	NA
	Flue Gas Mass Flow	Wood	4.3 g/s	5.7 g/s	4.7 g/s	3.8 g/s	5.0 g/s
	Flue Gas Mass Flow	Smokeless Fuel	NA	7.9 g/s	NA	NA	NA
	Flue Outlet Size (Top or Rear Option)		125mm	125mm	125mm	125mm	125mm
VENTILATION	<ul style="list-style-type: none"> <li>- Where leakage is greater than 5m<sup>3</sup>/hour/m<sup>2</sup></li> <li>- Ventilation normally required = 550mm<sup>2</sup> per kW output over 5kW</li> </ul>		<b>NONE</b>	<b>NONE</b>	<b>NONE</b>	<b>NONE</b>	<b>NONE</b>
	<ul style="list-style-type: none"> <li>- Where leakage is less than or equal to 5m<sup>3</sup>/hour/m<sup>2</sup></li> <li>- Ventilation normally required = 550mm<sup>2</sup> per kW output</li> </ul>		2640mm <sup>2</sup>	2255mm <sup>2</sup>	2585mm <sup>2</sup>	2200mm <sup>2</sup>	2420mm <sup>2</sup>

For further information on ventilation please refer to Building Regulations Document J or your installer. This stove has been designed and assembled so that it may be used to burn wood logs in a Smoke Control Area. Find out if you are in a Smoke Control Area by contacting your Local Authority.

The Derwent, Consort 4, Consort 5 and Compact 5 and Consort 5 Slimline have been fitted with a permanent stop that prevents closure of the secondary air slider. Removal of this will lead to the appliance potentially causing smoke emissions. Without the permanent stop in place the appliance is not an exempt appliance and so may leave the householder liable for a fine up to £1000.

# Technical Specification

 		CONSORT 7	CONSORT 9 SLIMLINE	CONSORT 9	CONSORT 15	
<b>GENERAL</b>	Energy Efficiency Class		A	A	A	A
	Nominal Heat Output	Wood	5.4kW	4.9kW	9.1kW	11.9kW
		Smokeless Fuel	6.5kW	NA	7.8kW	9.0kW
	Energy Efficiency		101	96	105	105
	Efficiency	Wood	75.9%	72.4%	78.9%	78.6%
	Efficiency	Smokeless Fuel	67.3%	NA	68.5%	79.4%
	Mean CO (@13% O <sub>2</sub> )	Wood	0.27%	0.25%	0.38%	0.57%
	Mean CO (@13% O <sub>2</sub> )	Smokeless Fuel	0.22%	NA	0.35%	0.18%
	Appliance Mass		111kg	108kg	120kg	163kg
	Recommended Fuels	Wood	Seasoned Wood (less than 20% moisture content)			
		Smokeless Fuel	Anthracite or a manufactured briquette smokeless fuel which is suitable for closed door appliances.			
Log Length		380mm	400mm	500mm	500mm	
<b>FLUES</b>	Mean Flue Gas Temperature	Wood	265°C	271°C	293°C	339°C
	Mean Flue Gas Temperature	Smokeless Fuel	332	NA	304°C	275°C
	Flue Gas Mass Flow	Wood	5.7 g/s	6.2 g/s	6.4 g/s	6.4 g/s
	Flue Gas Mass Flow	Smokeless Fuel	NA	NA	8.5 g/s	7.2 g/s
	Flue Outlet Size (Top or Rear Option)		150mm	125mm	150mm	150mm
<b>VENTILATION</b>	<ul style="list-style-type: none"> <li>- Where leakage is greater than 5m<sup>3</sup>/hour/m<sup>2</sup></li> <li>- Ventilation normally required = 550mm<sup>2</sup> per kW output over 5kW</li> </ul>		825mm <sup>2</sup>	<b>NONE</b>	2255mm <sup>2</sup>	3795mm <sup>2</sup>
	<ul style="list-style-type: none"> <li>- Where leakage is less than or equal to 5m<sup>3</sup>/hour/m<sup>2</sup></li> <li>- Ventilation normally required = 550mm<sup>2</sup> per kW output</li> </ul>		2970mm <sup>2</sup>	2750mm <sup>2</sup>	5005mm <sup>2</sup>	6545mm <sup>2</sup>

For further information on ventilation please refer to Building Regulations Document J or your installer.

This stove has been designed and assembled so that it may be used to burn wood logs in a Smoke Control Area.

Find out if you are in a Smoke Control Area by contacting your Local Authority.

The Consort 7 and Consort 9 Slimline have been fitted with a permanent stop that prevents closure of the secondary air slider. Removal of this will lead to the appliance potentially causing smoke emissions. Without the permanent stop in place the appliance is not an exempt appliance and so may leave the householder liable for a fine up to £1000.

## IMPORTANT INFORMATION

**PLEASE READ THESE INSTRUCTIONS PRIOR TO INSTALLATION AND OPERATION. KEEP THESE INSTRUCTIONS IN A SAFE PLACE FOR FUTURE REFERENCE AND SERVICING.**

**THIS APPLIANCE WILL BECOME VERY HOT WHEN USED IN ACCORDANCE WITH THESE INSTRUCTIONS, HUNTER STOVES RECOMMEND THAT AN APPROVED GUARD IS USED TO PROTECT THE YOUNG, ELDERLY OR INFIRM FROM HARM.**

**THE INSTALLER COMMISSIONING SHEET CAN BE FOUND ON THE BACK COVER. PLEASE ENSURE THAT IT IS COMPLETED PRIOR TO USE.**

## General Guidance

It is important that your stove is correctly installed and operated as Hunter Stoves Group cannot accept responsibility for any fault arising through incorrect installation, use, maintenance or servicing.

These instructions cover the basic principles to ensure satisfactory installation of the stove, although detail may need slight modification to suit particular local site conditions.

The installation must comply with current Building Regulations, National and European Standards, Local Authority Byelaws and other specifications or regulations as they affect the installation of the appliance.

The Building Regulations requirements may also be met by adopting the relevant recommendations in the current issues of British Standards BS 8303 and BS EN 15287-1.

Only use approved fuels on this appliance. Information about this can be found on Page 20.

This is a Domestic Appliance and must only be used in accordance with these instructions. Do not place articles that are affected by high temperatures on, or near, this appliance. Do not place furniture or other items within 1 metre of the front of this appliance. See the note on material clearances on pages 15/16.

Fitting a stove in a room which also contains an extractor fan and/or cooker hood should be avoided where possible. If this is unavoidable, the suitability of the space for fitting this appliance must be decided at the discretion of a qualified installer, and a flue draught interference test must be performed.

Do not obstruct the ventilation required for the safe use of this appliance.

### **Competent Persons Scheme**

Hunter Stoves Group recommend that this stove is installed by a member of an accredited competent persons scheme e.g. HETAS.

If the installer is not a member of a competent person's scheme, it is a legal requirement, in the UK, to notify your Local Building Control Officer in advance of any installation work starting.

### **Health and Safety Precautions**

Special care must be taken when installing the stove such that the requirements of the Health and Safety at Work Act are met.

### **Handling**

This appliance is very heavy. Adequate facilities must be available for loading, unloading and site handling.

### **Fire Cement**

Some types of fire cement are caustic and should not be allowed to come into contact with the skin. In case of contact, wash immediately with plenty of water.

### **Asbestos**

This stove contains no asbestos. If there is a possibility of disturbing any asbestos in the course of installation, then please seek specialist guidance and use appropriate protective equipment.

## **Metal Parts**

When installing or servicing this stove, care should be taken to avoid the possibility of personal injury.

## **Modification**

No unauthorised modification of this appliance should be carried out.

# **Safety**

**WARNING** – This appliance will be hot when in operation and due care should be taken. The supplied operating tool or glove may be used to open the door and operate the air controls.

## **Aerosols**

Do not use an aerosol spray on or near the stove when it is alight.

## **Fireguards**

Always use a fireguard in the presence of children, the elderly or the infirm. The fireguard should be manufactured in accordance with BS8423 – Fireguards for use with solid fuel appliances.

## **Do not Over-Fire**

It is possible to fire the stove beyond its design capacity. This could damage the stove so watch for signs of over-firing. If any part of the stove starts to glow red, the stove is in an over-fire situation and the controls should be adjusted accordingly. Never leave the stove unattended for long periods without first adjusting the controls to a safe setting. Careful air supply control should be exercised at all times.

## **Fume Emission**

Properly installed, operated, this appliance will not emit fumes. Occasional fumes from de-ashing and refuelling may occur. Persistent fume emission must not be tolerated.

***This appliance should not be operated with the door open.***

If fume emission persists, then the following immediate action should be taken: -

- Open doors and windows to ventilate the room.
- Let the fire go out or eject and safely dispose of fuel from the appliance.
- Check for flue/chimney blockage and clean if required.
- Do not attempt to re-light the fire until the cause of the fume emission has been identified and corrected.

If necessary, seek expert advice.

## **Adverse Weather**

In a small number of installations, occasional local weather conditions (e.g. wind from a particular direction) may cause downdraught in the flue and cause the stove to emit fumes. In these circumstances, the stove should not be used. A professional flue installer will be able to advise on solutions to this problem (e.g. anti-downdraught cowl).

## **Carbon Monoxide Detector**

Hunter Stoves recommend a Carbon Monoxide Detector that conforms to the latest issue of BS EN 50292 is placed in the same room as the appliance. The installation of such an alarm is not considered as a substitute for regular maintenance or servicing of the appliance and Flue system.

## **IN THE EVENT OF A CHIMNEY FIRE:**

- Raise the alarm
- Call the Fire Brigade
- Close appliance air controls
- Move furniture, ornaments etc. away
- Place a fireguard in front of stove
- Check the chimney breast for signs of excessive heat.

If the wall is becoming excessively hot, move furniture away.

Ensure the Fire Brigade can gain access to your roof space in order to check for fire spread.

# Removing Internal Components

All internal components must be removed prior to fitting the stove. This will make handling the stove easier; allow access to fixings and the flue outlet; as well as protect the internal components from damage during the installation process.

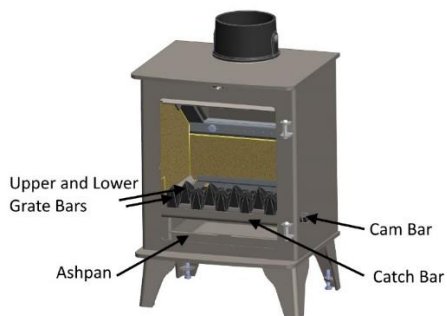

1. Open the door and remove the ashpan.
2. Remove the grate bars by lifting the front up off the cam bar and sliding forward off the rear grate support and lift out of the firebox.
3. Remove the cam bar by lifting the left-hand end of it upwards until it clears the side casting. Pull the left-hand end towards the front of the stove and then slide all the way out. Take care not to lose the cam hole plate.
4. Remove the catch bar by lifting upwards and pulling forwards out of the stove body.

## Side Plates

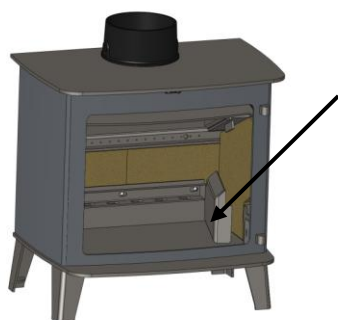

Slide out both Side Plates

## Side Bricks

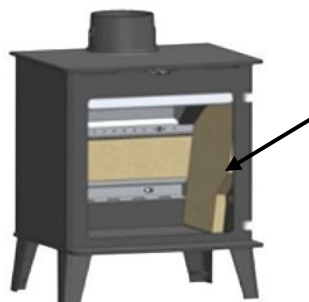

Slide the base of the Side Brick towards the centre of the stove and remove.

## Rear Brick

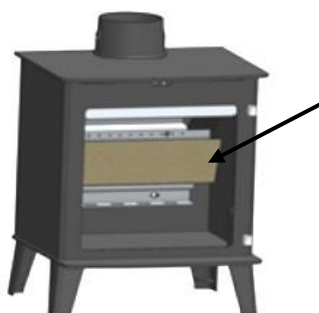

Pull the top edge of the Rear Brick forward and lift the brick out of the Stove.



## Baffle/Throat Plate



Lift the Baffle and slide to the left. When the right side of the Baffle clears the Baffle Support, lower the Baffle into the Fire Box and remove.

## Stove Assembly

### Flue Collar

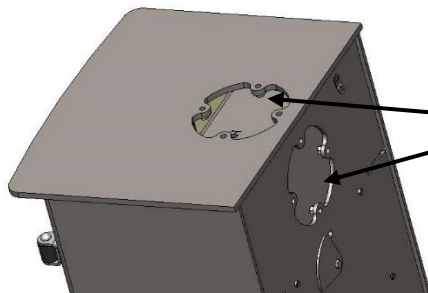

Top or rear outlet

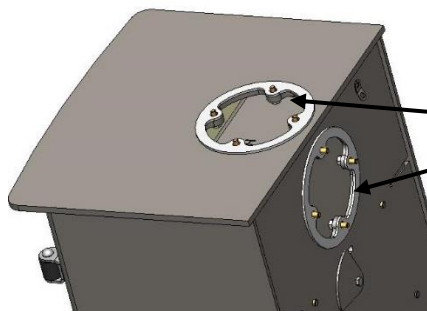

Place the flue collar gasket on the outlet to be used.

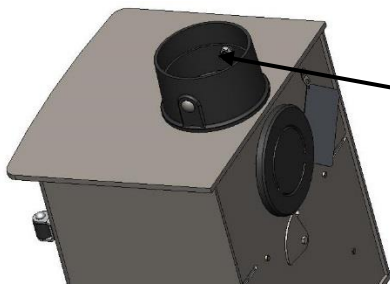

Place the bolts downwards through the fixing holes (head side upwards). Then tighten by using supplied nuts from inside stove.



Place the gasket on the outlet and put blanking plate on top of this. Screw the bolts from the inside of the stove into the blanking plate.

## Re-Assembling The Stove

Refit all the internal parts by following the 'removing internal component' instructions in reverse order.

### APPLIANCE DIMENSIONS

#### DERWENT

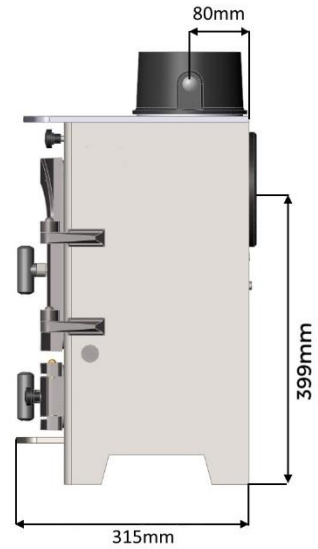
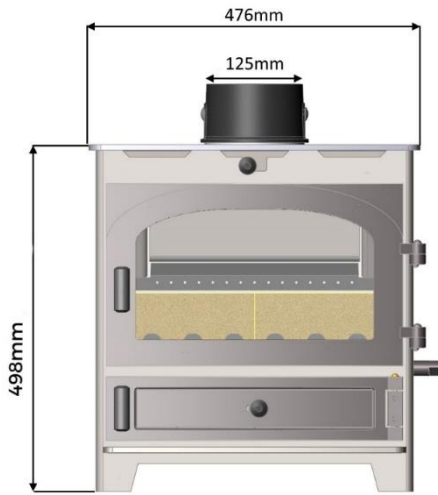

#### CONSORT 4

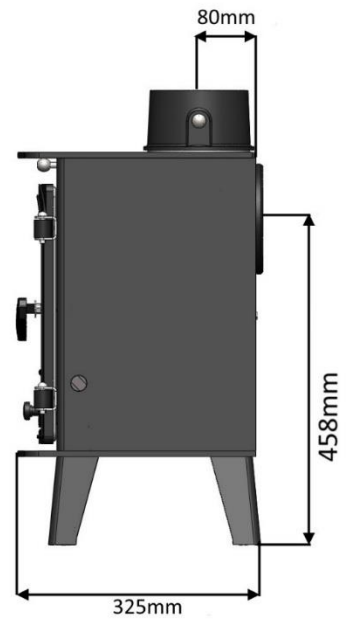
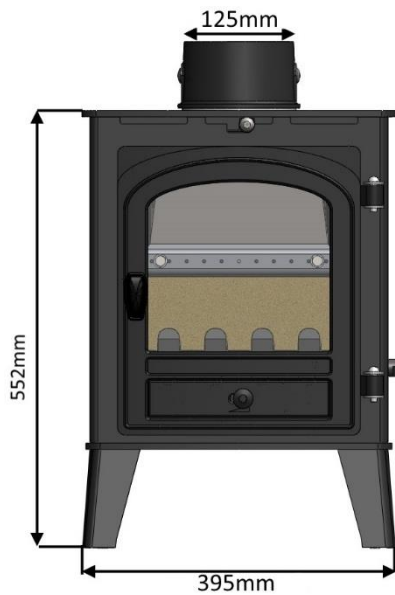

#### CONSORT 5

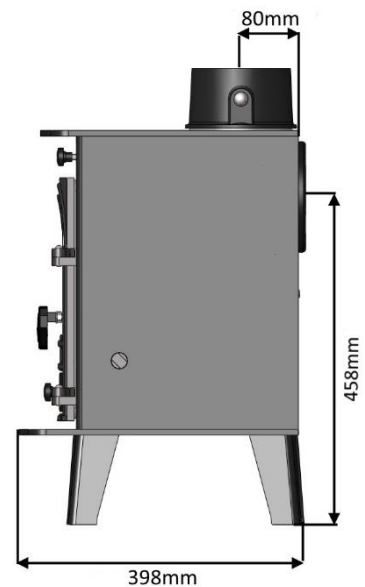
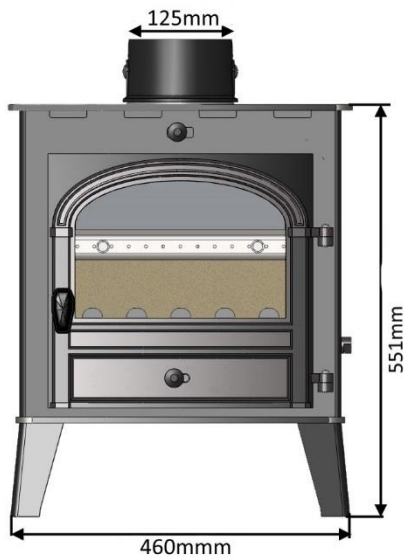

## **COMPACT 5**

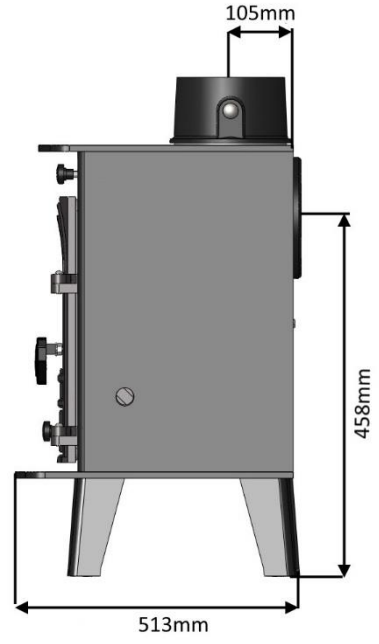
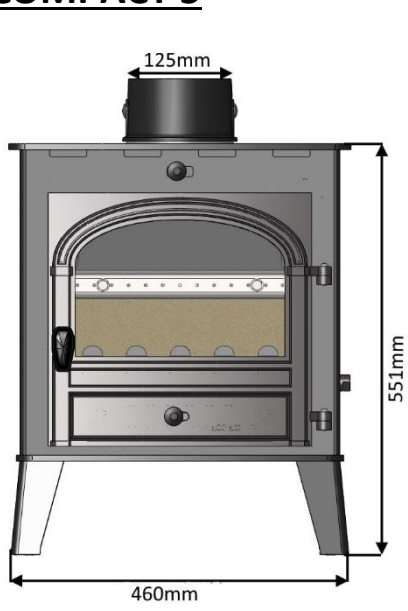

## **CONSORT 5 SLIMLINE**

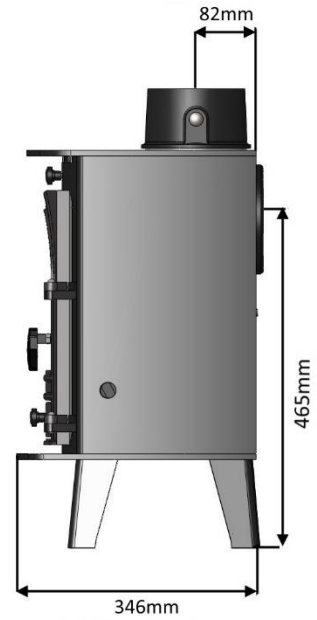
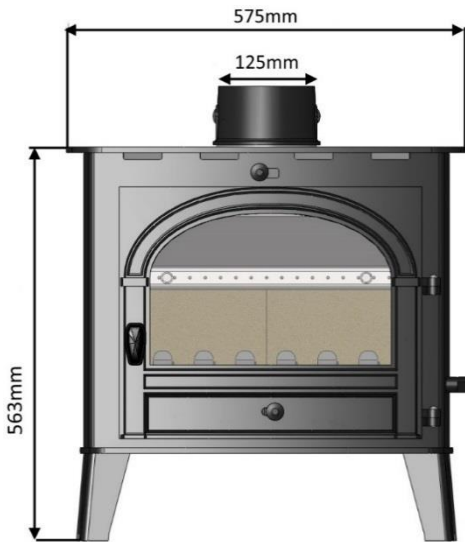

## **CONSORT 7**

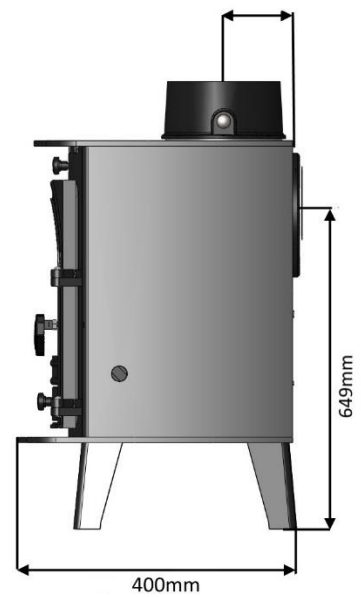

## CONSORT 9 SLIMLINE

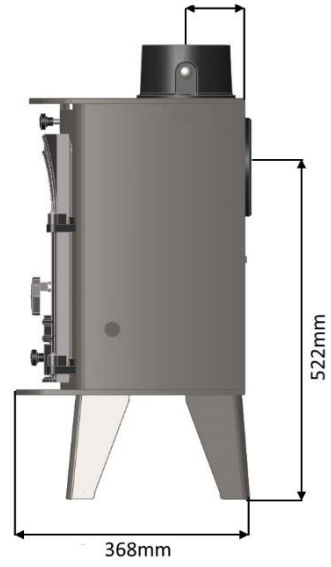
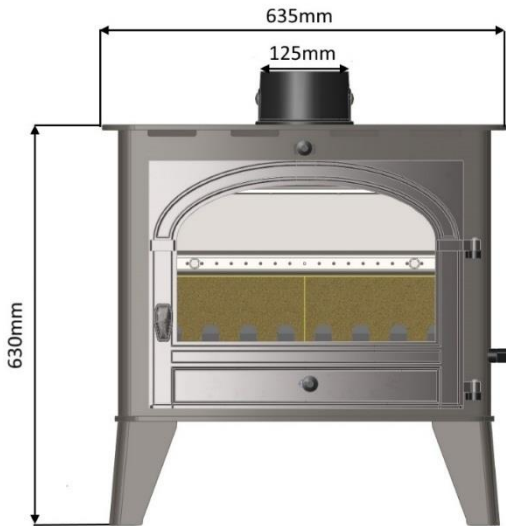

## CONSORT 9

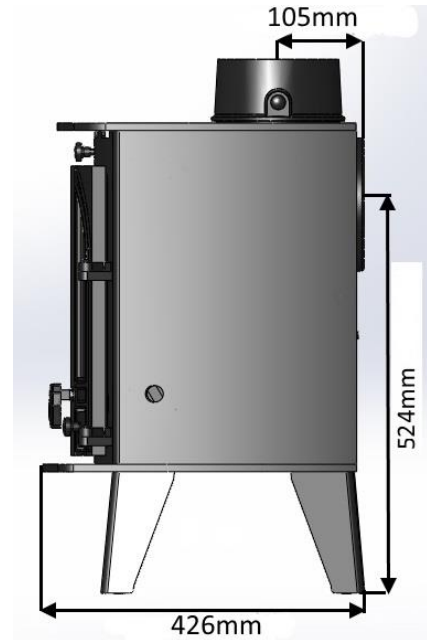

## CONSORT 15

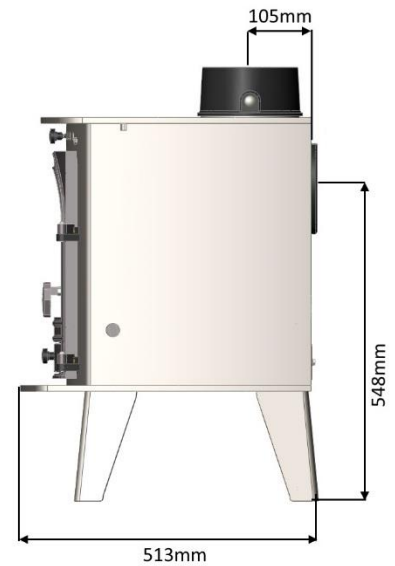
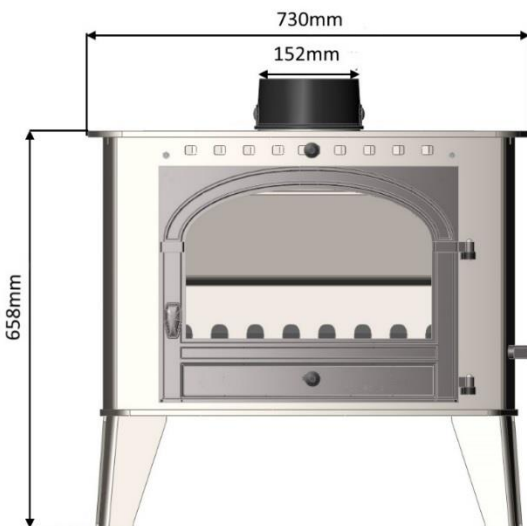

## Pre-Installation Requirements

### PLEASE CHECK THE FOLLOWING:

Any existing chimney/flue system must be confirmed as suitable for this appliance as defined in Building Regulations Document J. It must be swept and inspected, by a competent person (see notes), to confirm that is structurally sound and free from cracks and obstructions.

The diameter of the Flue should not be less than  $\varnothing 125\text{mm}$  and not more than  $\varnothing 200\text{mm}$  – Derwent/Consort 4/Consort 5 and 5 Compact/5 Slimline/9 Slimline. For the Consort 7/Consort 9 and Consort 15 the Flue should not be less than  $\varnothing 150$  and note more than  $\varnothing 230\text{mm}$ . Do not connect to systems that have large voids or spaces. If any of these requirements are not met, the chimney should be lined by a suitable method.

If the chimney is suspected of previously serving an open fire it must be swept again, within a month of regular use, to clear any soot that may have been dislodged due to the variation in combustion levels and higher flue gas temperature levels. The chimney/flue system exit must comply with Building Regulations Document J. The minimum height and should terminate in accordance with Table 1.

### Connection to the Chimney

An existing fireplace opening can be bricked up or sealed with a register plate. A short length of flue pipe of minimum 125mm (Derwent, Consort 4, Consort 5, Compact 5, 5 Slimline, 9 Slimline) internal diameter may then be used to connect the stove to the chimney. This increases to 152mm for Consort 7, Consort 9 and Consort 15. This flue pipe should be made of 316 grade stainless steel or vitreous enamelled steel, nominal thickness 1.2mm. Ensure that the pipe end is no closer than 76mm to the chimney walls. The length of any horizontal run of flue pipe must not exceed 125mm (Derwent, Consort 4, Consort 5, Compact 5, 5 Slimline and 9 Slimline) and 152mm (Consort 7, Consort 9, Consort 15). It is essential that all connections between the stove and chimney-flue are sealed and made airtight.

Make provision to access the chimney/flue system for cleaning and the removal of debris. If there is no existing chimney then either a prefabricated block chimney in accordance with Building Regulations Approved Document J, or a twin-walled insulated stainless-steel flue to BS4543 can be used. These chimneys must be fitted in accordance with the manufacturer's instructions and Building Regulations. New masonry and flue block chimneys must meet the requirements of Building Regulations Document J. Any connecting flue pipe systems must also meet these regulations.

Please check the suitability of the fireplace and/or surround for use with this appliance before installing it. If you have any doubts about the suitability of your chimney, consult your local Dealer/Stockist or Installation Engineer. Both the chimney and flue pipe must be accessible for cleaning and if ANY part of the chimney cannot be reached through the stove (with baffle removed), a soot door must be fitted in a suitable position.

### FLUE OUTLET POSITIONS (DOCUMENT J):

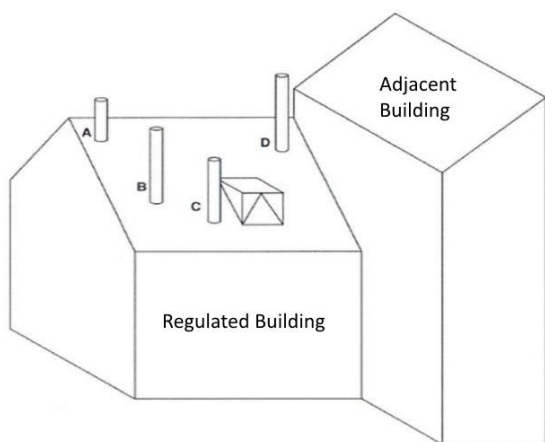

	Position on Roof	Clearances to flue exit
A	At or within 600mm of the ridge	At least 600mm above the ridge
B	Elsewhere on a roof (Pitched or Flat)	At least 2.3 M horizontally from the nearest point on the weather surface and: a) At least 1.0 M above the highest point of intersection between the chimney and weather surface; or b) at least as high as the ridge
C	Below (on a pitched roof) or within 2.3 M horizontally to an opening window or dormer	At least 1.0 M above the top of the opening
D	Within 2.3 M of an adjoining or adjacent building, whether or not beyond the boundary	At least 600mm above any part of the adjacent building within 2.3 M

A full copy of Document J can be found here:  
[http://www.planningportal.gov.uk/uploads/br/BR\\_PDF\\_ADJ\\_2010.pdf](http://www.planningportal.gov.uk/uploads/br/BR_PDF_ADJ_2010.pdf)

Table 1

## **Legal Requirements**

Hunter Stoves Group requests that before installation and/or use of this appliance that you read these instructions carefully to ensure that all the relevant requirements are fully understood.

These instructions cover the basic principles to ensure satisfactory installation of the stove, although detail may need slight modification to suit particular local site conditions. In all cases the installation must comply with current Building Regulations, Local Authority Byelaws, European and National Standards and other specifications or regulations as they affect the installation of the stove.

It should be noted that the Building Regulations requirements may be met by adopting the relevant recommendations given in British Standards BS 8303, BS 6461 and BS 7566 as an alternative means to achieve an equivalent level of performance to that obtained following the guidance given in Approved Document J.

Your local Building Control Officer can advise you regarding the interpretation of the Regulations should there be any questions.

This appliance must be installed by a Registered Installer (see Competent Persons Scheme) or approved by your local Building Control Officer.

All works undertaken must be carried out with due care and attention to meet the requirements of the Health & Safety code of practice and any other legislation that may have been introduced since the publication of these instructions.

### **Competent Persons Scheme**

Members of the following schemes may self-certify the installation of this stove. If the installer is not a member of one of these schemes, your local Building Control Department must approve the installation.

<b>Scheme</b>	<b>Web address</b>	<b>Telephone</b>
APHC (Association of Plumbing and Heating Contractors (Certification) Limited)	<a href="http://www.aphc.co.uk">www.aphc.co.uk</a>	02476 470 626
Building Engineering Services Competence Accreditation (BESCA Limited)	<a href="http://www.hvca.org.uk">www.hvca.org.uk</a> / <a href="http://www.besca.org.uk">www.besca.org.uk</a>	0800 652 5533
HETAS Ltd (Heating Equipment Testing and Approval Scheme)	<a href="http://www.hetas.co.uk">www.hetas.co.uk</a>	01462 634721
NAPIT Registration Ltd	<a href="http://www.napit.org.uk">www.napit.org.uk</a>	0870 444 1392
NICEIC Group Ltd	<a href="http://www.niceic.org.uk">www.niceic.org.uk</a>	0800 013 0900

### **Air Supply**

The room or space containing this appliance does not need a permanent, unobstructed air opening – Derwent, Consort 4, Consort 5, Compact 5, 5 Slimline, 9 Slimline.

The following require a permanent, unobstructed air opening of: -

Consort 7 – 220mm<sup>2</sup>

Consort 9 – 225mm<sup>2</sup>

Consort 15 – 3795mm<sup>2</sup>

(see Technical Specification sheet for confirmation)

If a draught stabiliser is fitted, the air opening should be at least: -

Derwent - 1440mm<sup>2</sup>.

Consort 4 – 1350mm<sup>2</sup>

Consort 5 – 1230mm<sup>2</sup>

Consort 5 Compact – 1230mm<sup>2</sup>

Consort 5 Slimline – 1230mm<sup>2</sup>

Consort 9 Slimline – 1500mm<sup>2</sup>

Consort 7 – 1275mm<sup>2</sup>

Consort 9 – 4985mm<sup>2</sup>

Consort 15 – 5865mm<sup>2</sup>

Due consideration should be given to air requirements for any other appliance in the same room or space. Any air opening must be kept clear from blockage or obstruction.

## Clearances

Hearth constructions must comply with the current building regulations.

Your stove must be installed on a floor with adequate load-bearing capacity, otherwise suitable measures should be taken.

If the existing construction does not meet this pre-requisite, suitable measures (e.g. load distributing plate).

Care should be taken to level the stove using the adjusting screws in the feet.

### Material Clearances

Minimum Distances to Combustible Material	Derwent	Consort 4	Compact 5	Consort 5	Slimline 5	Consort 7	Slimline 9	Consort 9	Consort 15
Behind the stove	750mm	650mm	750mm	650mm	650mm	650mm	750mm	1110mm	1100mm
At the side of the stove	400mm	400mm	350mm	400mm	400mm	400mm	450mm	700mm	650mm
In front of the stove	900mm	900mm	900mm	900mm	900mm	900mm	900mm	900mm	900mm

Note: combustible material refers to any material that will degrade when subjected to heat e.g. plaster.

No combustible material must be stored underneath the stove.

### Fireplace Recess (ALL)

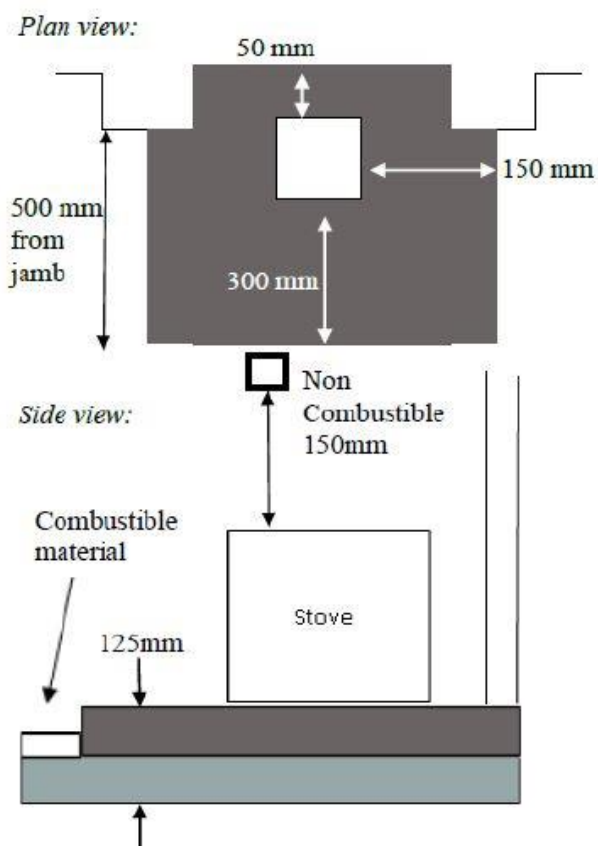

The stove can be recessed in a suitable sized fireplace but a permanent free air gap of at least 150mm on top and 50mm at the sides (although we recommend 150mm for the sides and 50mm at the back of the stove to obtain maximum heat output and for access to the rear of the stove.)

The hearth should extend at least 300 mm from the front of the stove. The stove should stand wholly above a solid, non-combustible hearth, at least 125 mm thick (this may include the thickness of a solid floor and a non-combustible decorative hearth).

## Free-Standing (Not Consort 9 Or 15)

Plan view:

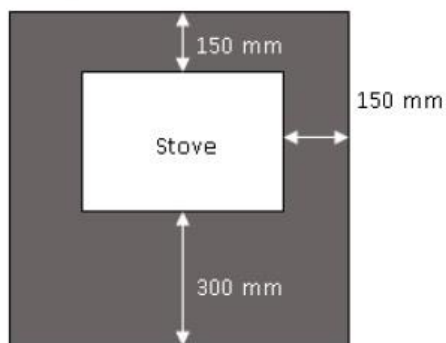

Side view:

Change in level to mark safe perimeter

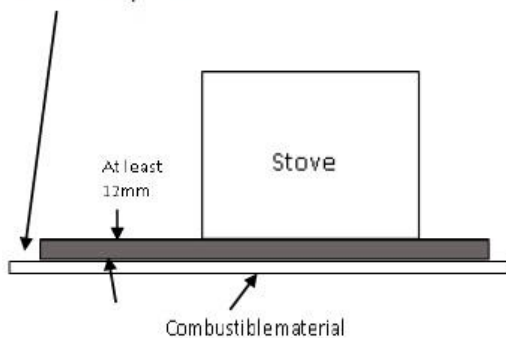

If the stove is not to stand in a recess, it may stand wholly above a hearth made of non-combustible board / sheet material or tiles, at least 12mm thick. The hearth should extend at least 150 mm from the sides and rear of the stove, and at least 300 mm from the front of the stove.

All walls shown in the above diagrams are non-combustible unless otherwise indicated. All non-combustible walls closer than 300mm to the stove should be at least 75mm thick.

## Commissioning & Handover

### Appliance Check

Please check that all components are correctly assembled and working correctly.

Ensure the Air Controls are working correctly.

Hunter Stoves Group recommend that you carry out a smoke draw test to check the soundness of the chimney/flue system and seals:

Place a Smoke Pellet in the centre of the Grate, ensure that all of the Air Controls are fully open and close the Door. The smoke should now be drawn up the chimney and you should be able to see it exit from the chimney/flue terminal. We recommend that you do this test with all of the windows and doors, to the room where the appliance is fitted, closed.

If there any adjoining room(s) that have an Extractor Fan fitted, open the adjoining door to ensure that the chimney/flue system is not compromised when the fan is operating. If there is a ceiling fan fitted in the room please operate it and ensure that it does not affect the operation of the chimney/flue system.

**If any of these tests fail, please re-check the suitability of the chimney/flue system together with the ventilation.**

A small fire can now be lit and allow the appliance to heat up slowly ensuring that no products of combustion enter into the room. Carry out a spillage test using a smoke match around the door opening. If there is excessive spillage, please allow the appliance to cool and then re-check the chimney/flue system and ventilation.

Do not run the stove at full output for at least 24 hours.

On completion of the commissioning:

Upon completion, allow a suitable period of time for any fire cement and mortar to dry out. Please instruct the user on the safe operation of this appliance, how the controls work and basic maintenance requirements.

Ensure that the operating instructions and appliance tools are left with the customer and the check lists have been filled out correctly. Please advise the customer on the correct use of the appliance with the fuels likely to be used



on the stove and warn them to use only the recommended fuels for the stove. Advise the user on what to do should smoke or fumes be emitted from the stove.

The user should be warned to use a fireguard to BS8423 in the presence of children, aged and/or infirm persons. Hunter Stoves Group also recommend that a CO alarm is fitted into the room where the appliance is located.

### **Flue Draught**

If the draught exceeds the recommended maximum, a draught stabiliser must be fitted so that the rate of burning can be controlled and to prevent over firing.

If the reading is less than the recommended minimum, then the performance of the appliance will be compromised. The flue draught should be checked under fire at high output with windows and doors closed. To take the reading remove one of the coach bolts in the flue collar and put the probe in the hole.

**Minimum Draught – 1.2mm Water Gauge**

**Maximum Draught – 2.5mm Water Gauge**

### **THE CLEAN AIR ACT 1993 AND SMOKE CONTROL AREAS**

Under the Clean Air Act local authorities may declare the whole or part of the district of the authority to be a smoke control area. It is an offence to emit smoke from a chimney of a building, from a furnace or from any fixed boiler if located in a designated smoke control area. It is also an offence to acquire an "unauthorised fuel" for use within a smoke control area unless it is used in an "exempt" appliance ("exempted" from the controls which generally apply in the smoke control area).

In England appliances are exempted by publication on a list by the Secretary of State in accordance with changes made to sections 20 and 21 of the Clean Air Act 1993 by section 15 of the Deregulation Act 2015. In Scotland appliances are exempted by publication on a list by Scottish Ministers under section 50 of the Regulatory Reform (Scotland) Act 2014. Similarly, In Northern Ireland appliances are exempted by publication on a list by the Department of Agriculture, Environment and Rural Affairs under Section 16 of the Environmental Better regulation Act (Northern Ireland) 2016.

In Wales appliances are exempted by regulations made by Welsh Ministers.

Further information on the requirements of the Clean Air Act can be found here: <https://www.gov.uk/smoke-control-area-rules>

Your local authority is responsible for implementing the Clean Air Act 1993 including designation and supervision of smoke control areas and you can contact them for details of Clean Air Act requirements.

The Aspect wood burning stoves have been recommended as suitable for use in smoke control areas. Suitable Authorised fuels can also be used in the appliances in Smoke Control Areas (see Authorised fuel list <https://smokecontrol.defra.gov.uk/fuels.php> )

### **Refuelling on to a low fire bed**

If there is insufficient burning material in the firebed to light a new fuel charge, excessive smoke emission can occur. Refuelling must be carried out onto a sufficient quantity of glowing embers and ash that the new fuel charge will ignite in a reasonable period. If there are too few embers in the fire bed, add suitable kindling to prevent excessive smoke.

### **Fuel overloading**

The maximum amount of fuel specified in this manual should not be exceeded, overloading can cause excess smoke.

### **Operation with door left open**

Operation with the door open can cause excess smoke. The appliance must not be operated with the appliance door left open except as directed in the instructions.

### **Dampers left open**

Operation with the air controls or appliance dampers open can cause excess smoke. The appliance must not be operated with air controls, appliance dampers or door left open except as directed in the instructions.

## **Operating Instructions**

***Read the 'General Guidance' Section at the start of these instructions before operating your stove for the first time.***

***Allow sufficient clearance between the stove and pictures, plasma screen televisions or ornaments etc., as these could be damaged and could potentially create a fire hazard (For more information read the 'Material Clearance' section of these installation instructions).***

***WARNING – This appliance will be hot when in operation and due care should be taken. The supplied operating tool or gloves may be used to open the door and operate the air controls.***

## **Please Note**

Your Building Insurance Company may require you to inform them of this new installation and that the work has been carried out correctly. Please check your policy to ensure that it is still valid when this installation is complete.

## **Using The Appliance For The First Time**

### **SAFETY ADVICE**

During the first operation it is highly likely that fumes and smells may be produced as part of the normal heat resistant paint curing process, much like a domestic oven. Therefore, good ventilation during this process is of utmost importance. We recommend that pregnant women, allergic persons and small children as well as domestic animals, especially birds, should not unnecessarily stay in subjected areas.

When being heated up for the first time, smells and fumes are often produced. This is a normal chemical process that allows the specialist heat resistant paint to cure and harden.

Please arrange for good ventilation of the room. Open windows and doors and if necessary, use a ventilator for fast interchange of air. Heat up to operation temperature for at least one hour. If maximum temperature is not achieved after heating up, release of odour may appear later.

## **Aerosols**

**Do not use an aerosol spray on or near the stove when it is alight.**

## **Air Control**

This stove has been designed to burn far more efficiently than a traditional stove if used correctly, with the obvious notable feature of CLEAN GLASS. It is essential that the stove has an adequate air supply for combustion and ventilation. The primary and secondary air inlets must be kept clear from obstruction and blockage.

### **Primary Air**

This provides a conventional air draught to the bed of the fire.

Primary air is controlled via the slider(s) in the door(s).

To increase air, move the slider to the right. This provides a conventional air draught to the bed of the fire.

### **Secondary Air**

Secondary air is controlled via the slider above the door(s); it is this "Airwash" that keeps a clean and uninterrupted view of the fire. The amount of air can be increased by moving the slider to the right.

### **Tertiary Air/Data Plate**

Tertiary air aids in good secondary combustion of the fuel and reducing emissions into the chimney and environment.

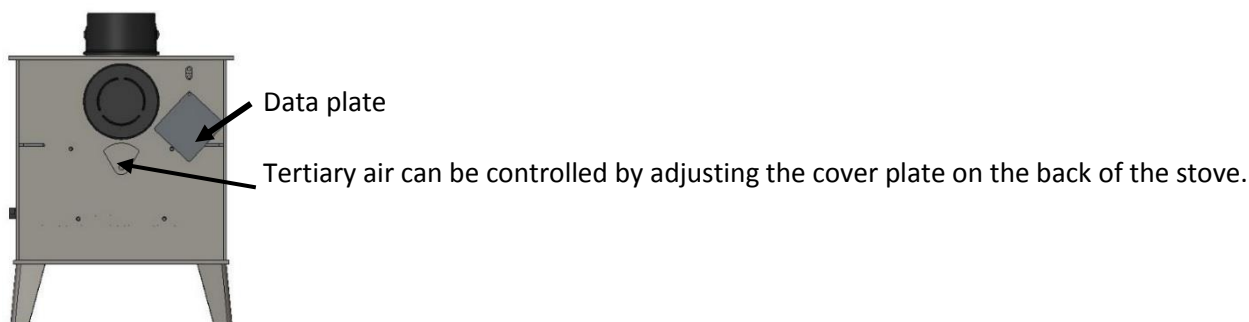

**Warning!** – This Appliance will be hot when in operation and due care should be taken. We advise that suitable gloves are used when operating the air control, and when opening the door.

## **Lighting the Stove**

To light the stove, open the primary and secondary air controls fully.

Light one or two firelighters placed centrally on the grate, allowing the flames to become established before placing several pieces of small dry kindling in a criss-cross fashion above the firelighters, taking care not to smother the fire.

Close the stove door. Once the kindling is well alight open the door and build the fire by gradually adding slightly larger pieces of wood, closing the door afterwards.

Once you have a good fire established across the grate bed, further fuel can be added as required and the air controls set to the correct position. Should the fire fail to light correctly open the door and use a poker to spread the fuel across the grate. Close the door and allow the fuel and stove to cool before attempting to relight the fire.

N.B. Leaving the air controls in the closed position, adding too much fuel or using wood that is wet or too large will prevent the fire from establishing correctly and may result in smoke emission from the stove.

## **Locomotive Grate**

### **Grate Operation & Burning Wood**

Your Consort is fitted with a locomotive type grate. So that de-ashing can be carried out cleanly and easily, it is riddled from the outside of the stove with the doors closed.

To burn wood, push the operating tool up and away from you.

When left in this position, air is restricted through the bed of the fire providing a solid base to build up a bed of ash.

Surplus ash can be removed either by gentle riddling or with a shovel.

It might prove beneficial when burning more reactive fuels to leave the grate in a “neutral” position, thus directing some under fire air and some over fire air to the fire bed.

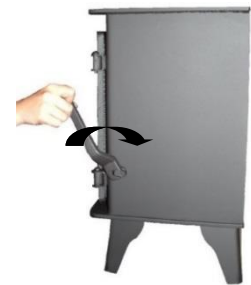

### **Grate Operation & Burning Solid Mineral Fuels**

**To burn solid mineral fuels**, place the operating tool over the riddling spigot and pull it towards you. When left in that position, air is directed under and up through the slots in the firebed, giving the optimum conditions for burning solid fuels.

It is important that the riddling tool is used to remove the ash to ensure airflow through the fire bed and allow the fire to burn over the entire area of the grate. The ashpan should be emptied at least daily and ash should never be allowed to build up over a period of time as this will result in damage to the fire bars. The flat end of the riddling tool can be used to carry the ashpan.

### **Loading The Appliance (Solid Mineral Fuel)**

Solid mineral fuel should be placed in the stove so that there is no more than a 30° incline of the fuel bed from front to back. It should **not** be stacked above the level of the rear firebrick as this may result in damage to the stove. With a full load of fuel, the stove will need to be refuelled approximately once every 2 hours.

### **Air Controls (Solid Mineral Fuel)**

Solid mineral fuel burns most efficiently with the secondary air control in the closed position. The primary valve lever can then be used to control the burn rate of the stove. Always de-ash before refuelling and do not let the ash build up to the underside of the grate bars. Solid mineral fuel produces ash, which if allowed to build up will stifle the airflow through the Primary air valve cavity and grate. This will eventually cause the fire to die. With some solid mineral fuels, a residue of burnt fuel or clinker will accumulate on the grate, allow the fire to go out periodically to remove this.

### **IMPORTANT!**

We cannot stress firmly enough how important it is to empty the ashpan regularly. Air passing through the fire bed cools the grate bars. Distortion or burning out the grate bars is nearly always caused by ash being allowed to build up to the underside of the grate.

## **Extended Burning (Solid Mineral Fuel)**

The stove can be banked up for extended burning. When burning solid fuel, empty the ashpan. Open air controls and let the fire burn brightly for a short period. Refuel and close both air controls, the exact setting required will depend on the fuel used and the chimney draw so some practice may be necessary.

To revive the fire, open the air controls until the fire is burning brightly de-ash if necessary and refuel. Set air controls as required.

**Never leave the stove unattended until you are certain that the flames are fully established.**

**Should the fire fail to light correctly** open the door and use a poker to spread the fuel across the bottom of the firebox. Close the door and allow the fuel and stove to cool before attempting to relight the fire.

## **Notes on Woodburning**

With a full load of wood, the stove will need to be refuelled approximately once every hour. Wood can be stacked in the stove, but care must be taken that logs do not touch the baffle. Overloading the stove can cause excess smoke to be emitted. Wood burns most efficiently with the secondary air valve lever in the open position and the primary control closed. Moving the secondary control will control the burn rate of the stove.

Note - primary and secondary air is needed to light the stove, see section entitled 'Lighting the Stove'

Wood burns most efficiently on a bed of ash and it is therefore only necessary to remove surplus ash from the stove occasionally.

If there is insufficient burning material in the fire bed to light a new fuel charge, excessive smoke emission can occur.

Refuelling must be carried out with a sufficient quantity of glowing embers and ash, so that the new fuel charge will ignite quickly. If there are too few embers, add some kindling to prevent excessive smoke.

Maximum Log Length:  
See Technical Specification

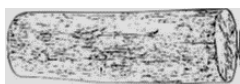

**Ensure your logs are well seasoned with a moisture content of less than 20%**

## **Reduced Combustion**

In order to shut down the stove, close the primary control, then close the secondary air slider by moving the handle all the way to the left. If the controls are left in this position, the fire will be starved of air and will die down.

If you want to revive the fire it is recommended that the primary air control is open first, and then open the secondary air slider. **Warning!** - The stove will remain **hot** for a considerable time after the fire has been extinguished.

## **Refuelling**

Refuelling must be carried out with a sufficient quantity of glowing embers and ash, so that the new fuel charge will ignite quickly. If there are too few embers, add some kindling to prevent excessive fuel. The air controls should not need adjusting while refuelling. (When refuelling it is important to have a damper in the open position if you have one.)

## **Recommended Fuels**

Hunter Stoves Group recommend that only wood logs with a moisture content of less than 20% and anthracite or a manufactured briquette smokeless fuel which is suitable for closed door appliances are used on this appliance.

Burning wet or unseasoned wood will create excess smoke emissions, tar deposits in the stove and chimney and will not produce a satisfactory heat output.

Only authorised fuels may be used in UK smoke control areas.

A list of authorised fuels can be found at - <http://uksmokecontrolareas.co.uk/fuels.php>

**WARNING - DO NOT BURN BITUMINOUS COAL, PETRO-COKE, OTHER PETROLEUM BASED FUELS OR TREATED WOOD SUCH AS PALLETS AS THIS WILL INVALIDATE THE PRODUCT WARRANTY. HOUSEHOLD WASTE MUST NOT BE BURNT ON THIS APPLIANCE.**

A list of approved fuels can be found at: - HETAS Ltd – Telephone 01242 673257 – [http://hetas.co.uk/public/hetas\\_guide.html](http://hetas.co.uk/public/hetas_guide.html)

Solid Fuel Association – Telephone 0800 600 000 – [www.solidfuel.co.uk](http://www.solidfuel.co.uk)

# Maintenance And Servicing

## WARNING!

NO unauthorised modification of this appliance should be carried out.

## IMPORTANT!

In order to ensure continued compliance with current Building Regulations and Local Authority Byelaws, this appliance requires regular maintenance by a competent person. N.B. Refer to the 'Removing Internal Components' section of the installation instructions for details on how to remove each component.

## Periods Of Prolonged Non-Use

If the stove is to be left unused for a prolonged period, then it should be given a thorough clean to remove ash and unburned fuel residues. To enable a good flow of air through the appliance to reduce condensation and subsequent damage, leave the air controls fully open. If the appliance has been unused for a long period, such as during the spring and summer months, a competent person should check the chimney for potential obstructions before lighting the stove *i.e. get the chimney swept before the start of the heating season?*

## Baffle

This should be removed and cleaned at least once a month to prevent any build-up of soot or fly ash that could lead to blocked flue ways and dangerous fume emission. If the baffle is removed the chimney/flue way can be swept through the appliance.

## Stove Body

**Painted Finish** - The stove is finished with a heat resistant paint and this can be cleaned with a dry soft brush or dry microfibre cloth. Do not clean whilst the stove is hot. **At no point should any water or other cleaning products be used on the stove.** The finish can be renovated with Hunter Stoves paint.

## Glass Panel

Clean the glass panel when cool with a propriety glass cleaner. Highly abrasive substances should be avoided as these can scratch the glass and make subsequent cleaning more difficult. Wet logs on heated glass, a badly aimed poker or heavy slamming of the doors could crack the glass panels. The glass will not fracture from heat. Should you need to replace a glass panel please ensure you purchase a new Gasket at the same time. Please check periodically that the glass clips and screws have not become loose. They should only be finger tight to allow for the expansion and contraction of the glass.

## Gaskets

All gasket used on this appliance are produced from a heat resistant material called Manniglas. The glass gasket will have to be replaced when a new piece of glass is fitted as the gaskets become brittle after firing the stove.

Over time you may also find that the gasket changes colour. This is due to a reduction in the pigment used in the manufacture of the product and no cause for concern.

## Firebricks

In normal use, these can last for many years. It is possible however, to crack them if logs are continually jammed against them or if they are frequently struck with a poker. Check periodically for seriously cracked bricks, which can be replaced with new, available from your dealer or our spares website [www.hunterstoves.co.uk](http://www.hunterstoves.co.uk).

## Door Catch

The door catch may require adjustment to maintain the door seal. By slackening the internal locking nut and turning the catch bolt one turn towards the door you will achieve a tighter lock when the door is closed.

## Rope

Check the 10mm or 12mm rope around the door. If rope is becoming detached, use rope glue to reattach it. If the rope is in a poor condition, a replacement rope kit may be ordered from the Hunter Stoves Group spares range.

## **Chimney and Flue ways**

It is important that the chimney, flue ways and any connecting flue pipe are swept regularly. This means at least once a year for smokeless fuels and at least twice a year for wood and other fuels. The baffle will need to be removed from its supports in order to sweep the chimney (see assembly instructions). Only wire-centred sweeps' brushes fitted with a guide wheel should be used. If it is not possible to sweep all parts of the chimney through the appliance, ensure there is adequate access to cleaning doors. If the stove is fitted in place of an open fire, then the chimney should be swept one month after installation to clear any soot falls which may have occurred due to the difference in combustion between the stove and the open fire.

## **Annual Service**

Hunter Stoves Group recommend that this appliance is serviced annually, preferably prior to the start of the heating season, thus avoiding any delay in receiving replacement components, should you need them. If you feel unable to undertake this task, Hunter Stoves recommend that you contact the installation engineer for advice.

Remove all the internal components: Riddling Bars, Cam Bar, Catch Bar, Ashpan, Side Plates and Baffle. Clean them carefully with a wire brush and inspect them for damage.

Sweep the chimney/flue system if necessary.

Clean down the internal surfaces of the appliance carefully using a scraper or wire brush.

Inspect these surfaces for damage/corrosion. If corrosion or damage is found, we advise that you consult with your installer about rectification/repair. Brush out or vacuum the inside of the appliance and re-fit the internal components.

Inspect the Glass and Gasket. Clean the Glass with a non-abrasive cleaner if required. If the Gasket is torn or damaged, we recommend that it is replaced to ensure that no products of combustion enter the room when the appliance is used.

**Painted Finish** - Brush down the outer surface with a soft brush or dry microfiber cloth only and touch up the paint if necessary.

Burn the appliance at a low rate, after maintenance, to allow any new seals, paint or glue cure properly.

The appliance may emit unpleasant odours during this process, please ensure the room is well ventilated.

The paint can be ordered through our website [www.hunterstoves.co.uk](http://www.hunterstoves.co.uk).

## TROUBLESHOOTING

	<b>ISSUE</b>	<b>CAUSE</b>	<b>RESOLUTION</b>
<b>OPERATION</b>	Problem starting the fire and keeping it burning	Low flue draught	Speak to your installer
		Wood with moisture content over 20%	Ensure use of dry seasoned wood with less than 20% moisture content
	Unable to control fire	High flue draught	Speak to your installer
	Short burn time	Wood with moisture content over 20%. Insufficient amount of fuel – refer to page 15 (Notes on Woodburning)	Ensure use of dry seasoned wood with less than 20% moisture content
	Over firing	High flue draught	Speak to your installer
		Air controls left fully open	Close air control to reduce output
	Low heat output	Low flue draught	Speak to your installer with advice on a suitable flue system.
		Wet wood (over 20% moisture content)	Ensure use of dry seasoned wood with less than 20% moisture content
Excessive fuel consumption	High flue draught	Speak to your installer	
	Over dry wood	Do not use constructional timber of pallet wood	
<b>SMOKE PROBLEMS</b>	Smoke and small flames	Wood with moisture content over 20%	Ensure use of dry seasoned wood with less than 20% moisture content
	Excessive smoke into room when appliance door is opened	Low flue draught	Speak to your installer
		Incorrect additional ventilation air in to the building	Speak to your installer
Continuous smoke spillage into the room when stove is in use	Blocked flue	Open all doors and windows to ventilate the room. Allow the fire to go out. Check flue for blockage. Do not re-use until the problem has been identified. If in doubt speak to your installer.	
<b>ADVERSE WEATHER</b>	Windy days causing spillage into the room	Down draught in flue caused by air turbulence due to nearby buildings or trees.	Weather conditions combined with the flue terminal position can have an effect on the stoves performance. Speak to your installer.
	Calm days causing spillage into the room	Over size flue giving poor flue draught	Weather conditions combined with the flue terminal position can have an effect on the stoves performance. Speak to your installer.
	Damp/Rainy days lighting and burning problems	Flue temperature low or rain water inside flue.	Use good quality wood to start and maintain the fire, speak to your installer to fit a rain cowl.
	Wind noise	High flue draught	Speak to your installer.

	ISSUE	CAUSE	RESOLUTION
<b>THE APPLIANCE</b>	Creosote build-up in chimney	Wood with moisture content over 20%	Use dry seasoned wood (less than 20% moisture content). Operate at a high temperature for short periods each time the appliance is used to avoid large build-ups of tars and creosotes.
	Tar coming from flue joints	Appliance operated at continuous low temperatures	Operate at a high temperature for short periods each time the appliance is used to avoid large build-ups of tars and creosotes. See user instructions for correct use of air control
		Using poor quality wood	Use dry seasoned wood (less than 20% moisture content).
	Dirty firebricks/glass	Wood with moisture content over 20%	Use dry seasoned wood (less than 20% moisture content).
	Glass blackening	Using poor quality wood	Use dry seasoned wood (less than 20% moisture content).
		Low flue draught	Speak to your installer.
		Incorrect use of air control	See user instructions for correct use of air control
		Appliance operated at low temperatures continuously	Operate at high output for short periods. See instructions for correct use of air control.

<b>FLUES</b>	<p>Flue systems have two main functions:</p> <ol style="list-style-type: none"> <li>1) To remove the smoke, fumes and combustion gasses from the building safely and efficiently</li> <li>2) To provide a sufficient amount of flue draught (suction) in the appliance to ensure the fire keeps burning correctly.</li> </ol> <p>The flue draught is caused by rising hot gases when the appliance is burning.</p> <p><b>If any flue issues persist then speak to your installer before continuing to use the stove.</b></p>
--------------	--



## OPTIONAL EXTRAS

These can be purchased through our website [www.hunterstoves.co.uk](http://www.hunterstoves.co.uk).

PRODUCT	CODE
Glass Cleaner (150mm Aerosol)	SCPGC
Fire Cement (500gm)	SCPFC500
Rope Glue (25ml)	SCPGLUE25ML
Gauntlet Gloves (Pair)	GGLOVE-HSG
Touch up Paint with Brush (236ml)	SCPPB
Spray Paint (400ml)	40.011400HSG
Flue Damper 5"	HHR99992
6"	HHR99988
<b>MULTIFUEL FRONT EXTENSION</b>	
Consort 4	CNS04019
Consort 5/5C	CND05015
Consort 7/5S	CNS07017
Consort 9S	CNS09035
Consort 9	CNS09035
Consort 15	CNS15030
<b>ROPE SEAL KIT</b>	
Derwent	SCPKRSK
Consort 4	SCPC4RSK
Consort 5/5C	SCPC5RSK
Consort 7/5S	SCPC57RSK (DOUBLE DOOR) SCPSC57RSK (SINGLE DOOR)
Consort 9S/9/15	SCPC915RSK (DOUBLE DOOR) SCPC915SDRSK (SINGLE DOOR)

## Spares Information

### Derwent – Single Door only

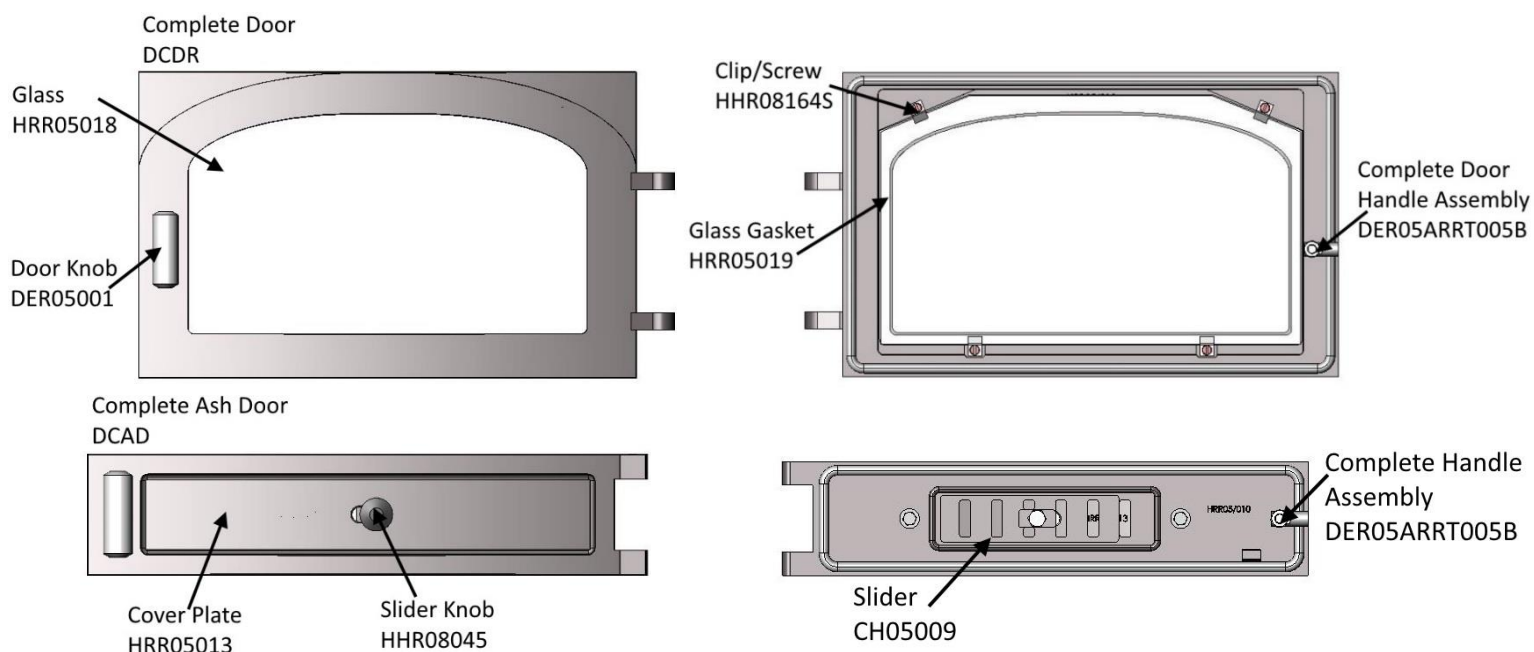

## Consort 4 – Single Door only

Complete Door  
DCN4S

Door Handle  
Assembly  
DHACN

Slider Knob  
HHR08045

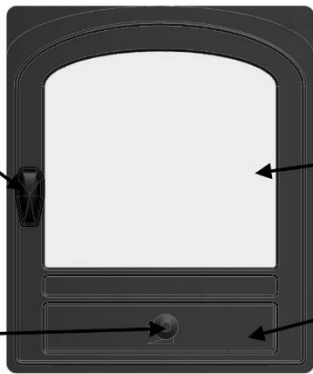

Glass  
HCR06058

Door Cover  
HCR06079

Rope Seal Kit  
SCPC4RSK

Glass Gasket  
HCR06080

Glass Clip/Screw  
HHR08164

Slider Plate  
CH08007

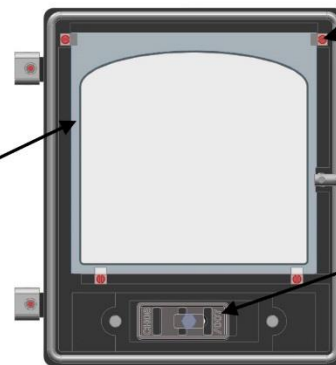

## Consort 5 and 5 Compact – Single Door only

Complete Door  
DC5S

Door Handle  
Assembly  
DHACN

Door Cover  
CND05005



Glass  
CND05006

Slider Knob  
HHR08045

Rope Seal Kit  
SCPC5RSK

Glass Gasket  
CND05007

Glass Clip and  
Screw HHR08164

Slider  
CH05009

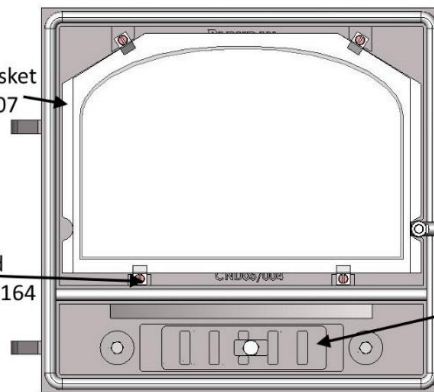

## Consort 5 Slimline and Consort 7

### Double Door - LH

Door Complete  
DC7L

Glass  
CH06018

Slider Knob  
HHR08045

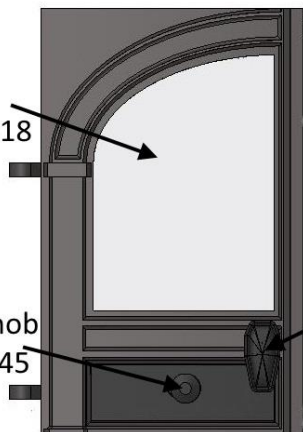

Door Knob  
CHC04010

Glass Gasket  
CH06019

Glass Clip/Screw  
HHR08164

Door Slider  
CH05033

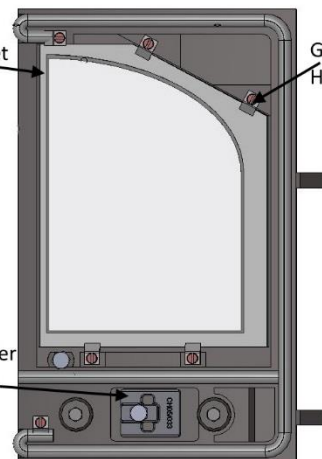

**Double Door – RH**

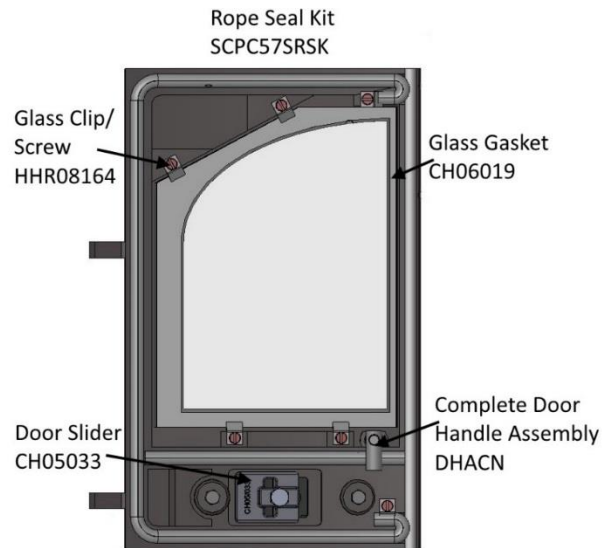
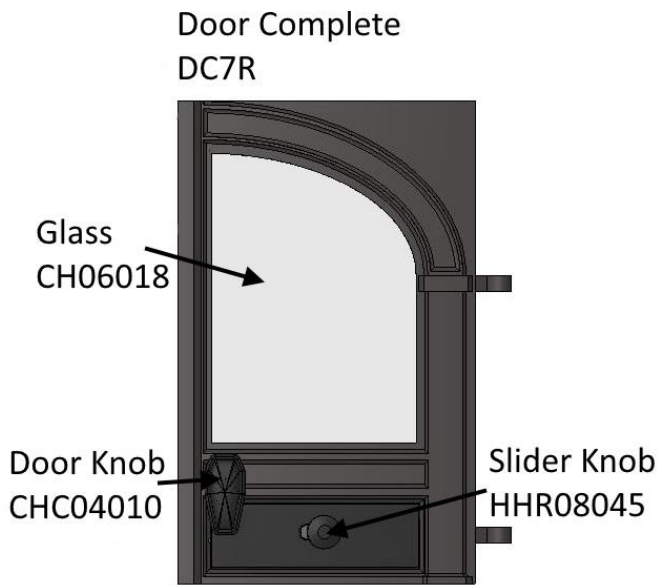

**Single Door**

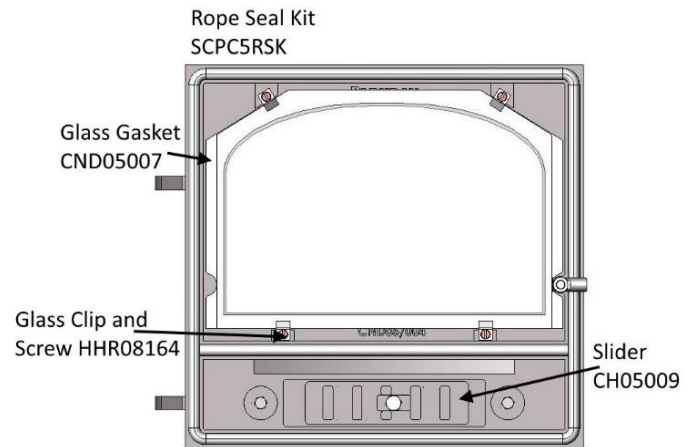
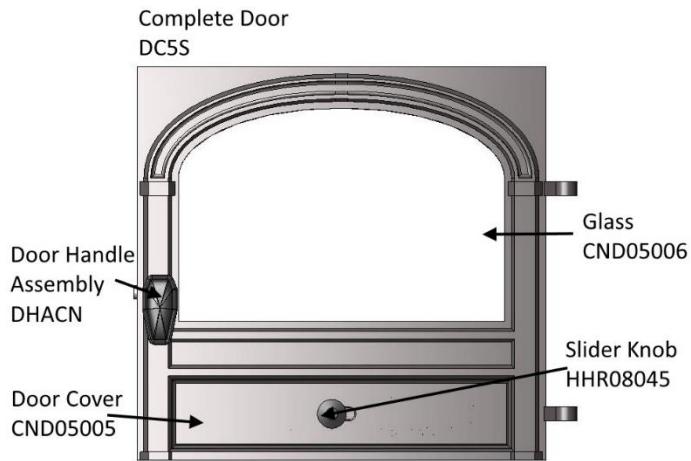

**Consort 9 Slimline, Consort 9 and Consort 15**

**Double Door - LH**

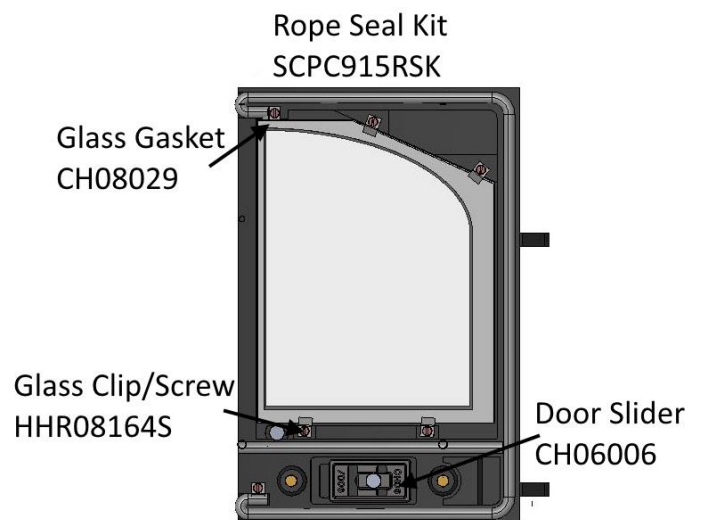
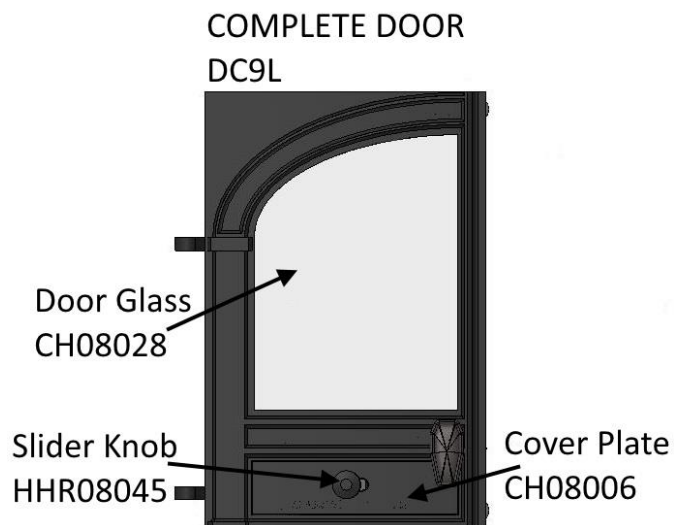

## Double Door – RH



## Single Door

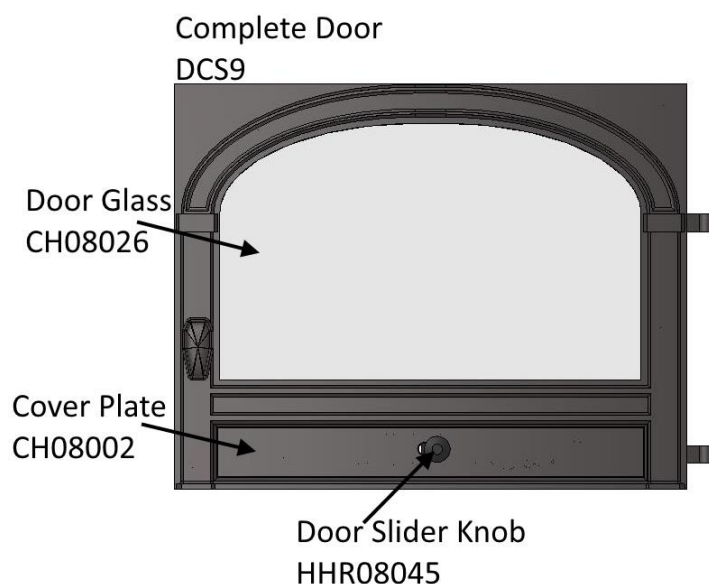

## TOP AIR DEFLECTOR

<u>MODEL</u>	<u>GASKET</u>	<u>PLATE</u>	<u>DEFLECTOR</u>	<u>SLIDER</u>	<u>SHAFT</u>	<u>KNOB</u>
Derwent	HH04088	HRR05037	HH04078	HH04090	HRR05007	HHR08045
Consort 4	HCR06076	HCR06108	HCR06077	HCR06072	HAW04017	HHR08045
Consort 5/5C	HH04088	HH04089	HH04078	HH04090	HAW04017	HHR08045
Consort 5 Slimline/7	HH06088	HH06086 (MF) HH06087 (WOOD)	HH06108 (1DR) HH06089 (2DR)	HH06086	HCE05021	HHR08045
Consort 9 Slimline/9/15	HHR14071	HHR14070	HHR14074 (1DR) HHR14072 (2DR)	HHR14069	HHR14073	HHR08045

# BODY ASSEMBLY SPARES

## DERWENT

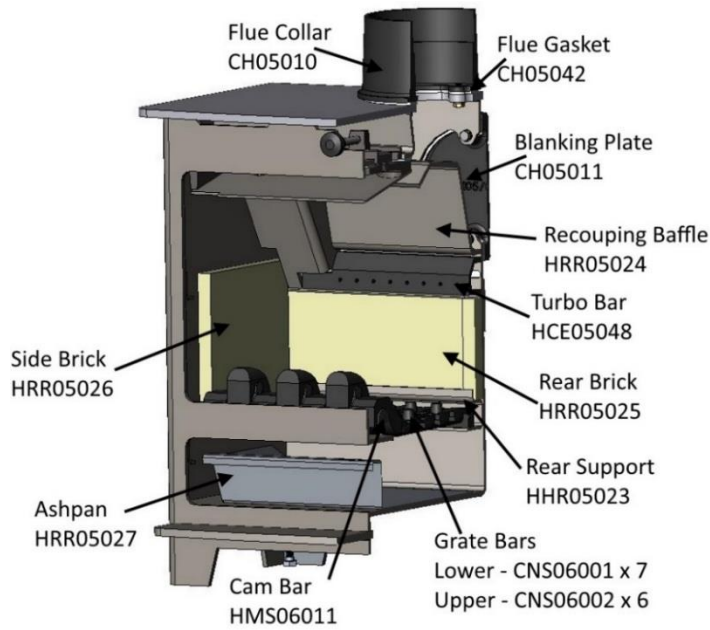

## CONSORT 4 – MULTIFUEL

Slider Top Air - HCR06072  
 Shaft - HAW04017  
 Gasket Top Air - HCR06076  
 Plate Top Air - HCR06108  
 Deflector Top Air - HCR06077

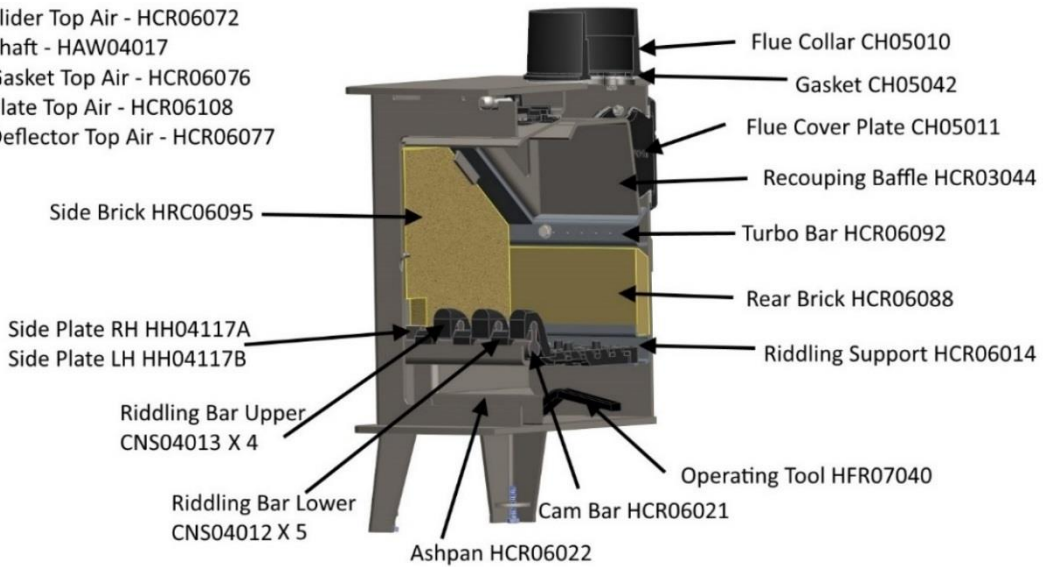

## CONSORT 4 – WOOD

Slider Top Air - HCR06072  
 Shaft - HAW04017  
 Gasket Top Air - HCR06076  
 Plate Top Air - HCR06108  
 Deflector Top Air - HCR06077

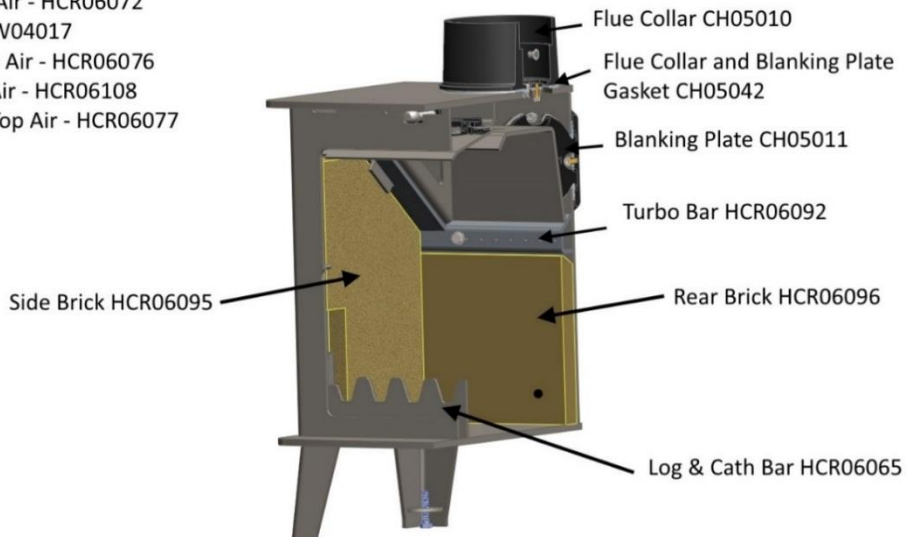

## CONSORT 5/5 COMPACT – MULTIFUEL

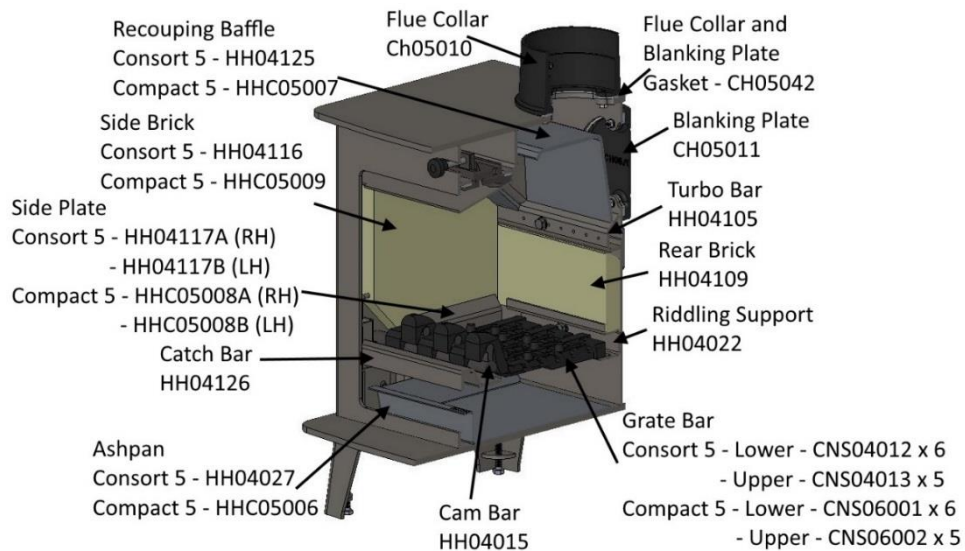

## CONSORT 5/5 COMPACT - WOOD

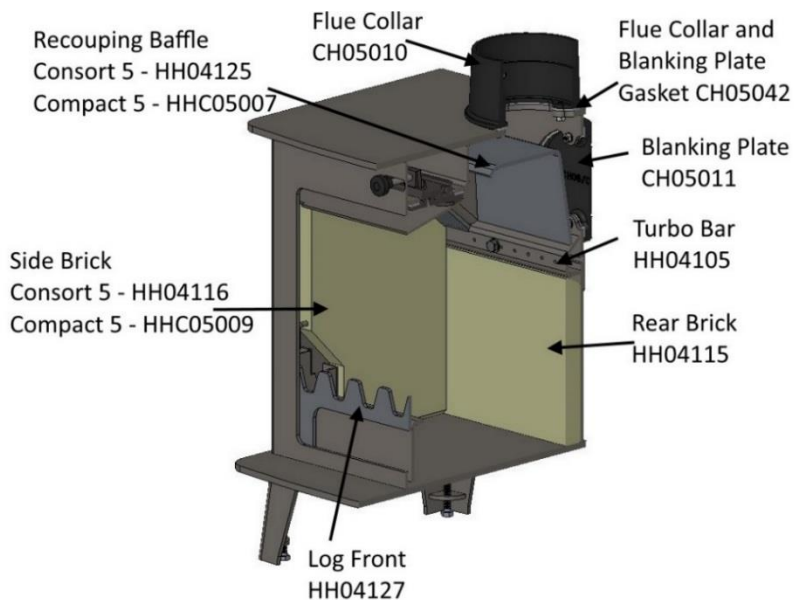

## CONSORT 5 SLIMLINE - MULTIFUEL

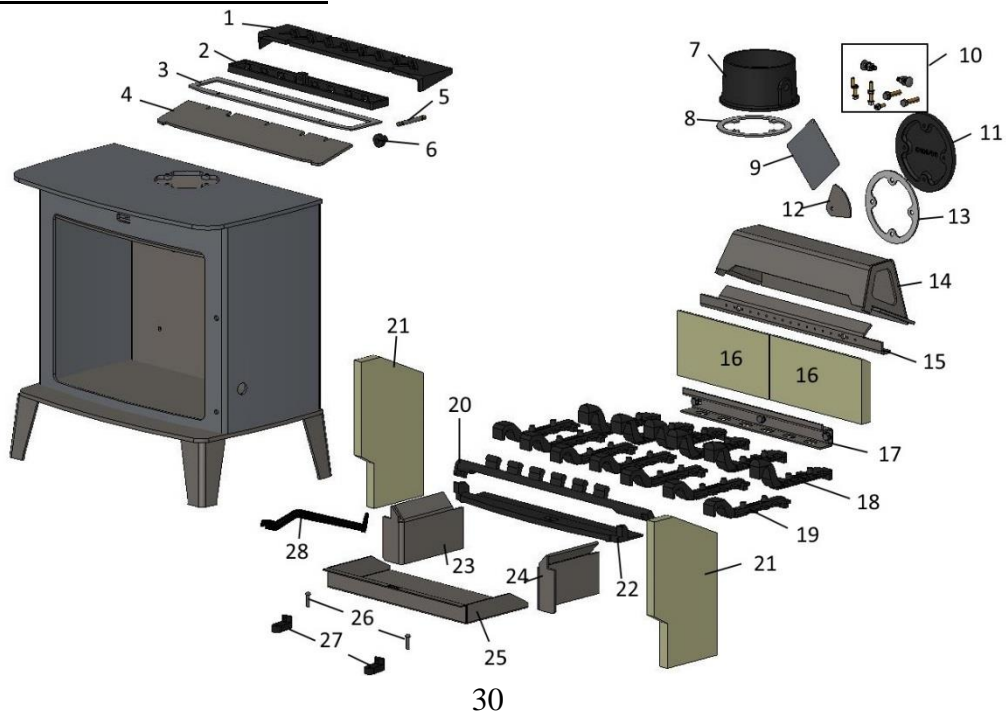

ITEM NO.	PART NUMBER	DESCRIPTION	QUANTITY
1	HH06087	PLATE, TOP AIR (BOTH DOOR TYPE)	1
2	HH06086	SLIDER, TOP AIR (BOTH DOOR TYPE)	1
3	HH06088	GASKET, TOP, AIR (BOTH DOOR TYPE)	1
4	HH06108	DEFLECTOR, TOP AIR (SINGLE DOOR)	1
4	HH06089	DEFLECTOR, TOP AIR (DOUBLE DOOR)	1
5	HCE05021	SHAFT, TOP AIR (BOTH DOOR TYPE)	1
6	HHR08045	SLIDER KNOB, MATT BLACK	1
7	CH05010	FLUE COLLAR (5")	1
8	CH05042	FLUE COLLAR GASKET	1
9	CNS05018	DATA PLATE	1
10	HHR99990/A	FLUE COLLAR/BLANKING PLATE FIXING PACK	1
11	CH05011	BLANKING PLATE	1
12	HHR14097	COVER, TERTIARY AIR INTAKE	1
13	CH05042	BLANKING PLATE GASKET	1
14	HHW05063	BAFFLE, RECOUPING	1
15	HH06101	TERTIARY AIR BAR	1
16	CNS05006	BRICK, REAR, MULTIFUEL	1 (BUT SENT IN TWO PIECES)
17	HH06022	REAR SUPPORT, RIDDLING BARS/REAR BRICK	1
18	CNS06002	RIDDLING BAR, UPPER	6
19	CNS06001	RIDDLING BAR, LOWER	7
20	HHR06007	CAM BAR	1
21	CNS05007	BRICK, SIDE, MULTIFUEL (EACH)	2
22	CNS07004	CATCH BAR (BOTH DOOR TYPE)	1
23	CNS05012B	SIDE PLATE, LH	1
24	CNS05012A	SIDE PLATE, RH	1
25	HHW05015	ASHPAN	1
26	FRRM06025	HINGE PIN	2
27	CH08064	HINGE	2
28	HFR07040	OPERATING TOOL	1

### CONSORT 5 SLIMLINE - WOOD

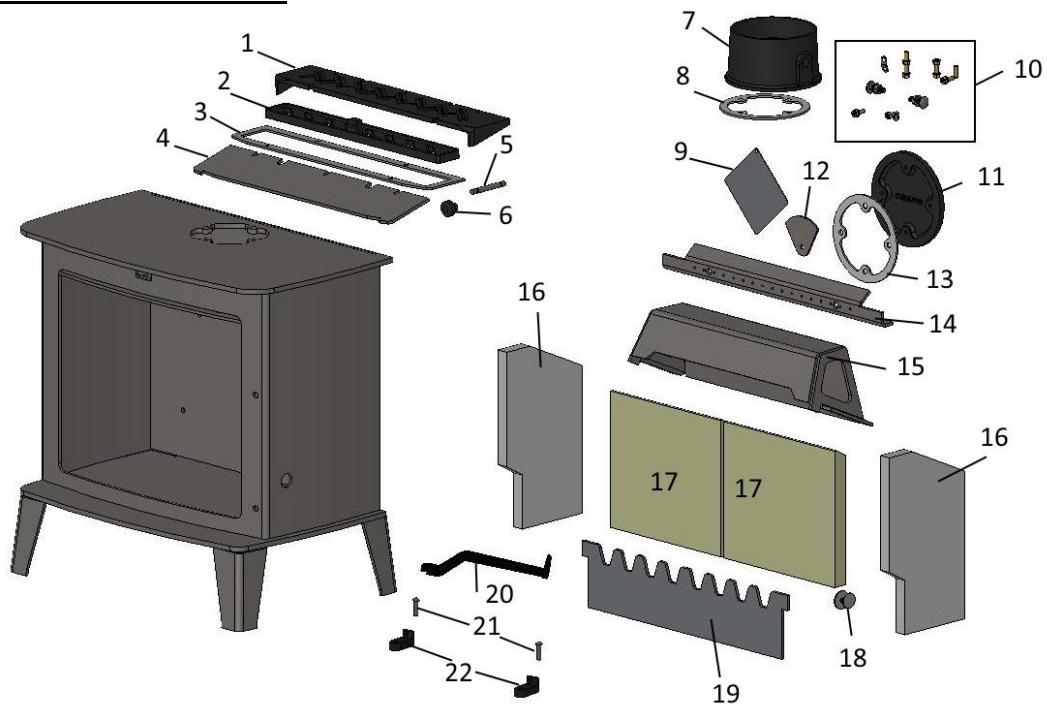

ITEM NO.	PART NUMBER	DESCRIPTION	QUANTITY
1	HH06087	PLATE, TOP AIR (BOTH DOOR TYPE)	1
2	HH06086	SLIDER, TOP AIR (BOTH DOOR TYPE)	1
3	HH06088	GASKET, TOP, AIR (BOTH DOOR TYPE)	1
4	HH06108	DEFLECTOR, TOP AIR (SINGLE DOOR)	1
4	HH06089	DEFLECTOR, TOP AIR (DOUBLE DOOR)	1
5	HCE05021	SHAFT, TOP AIR (BOTH DOOR TYPE)	1
6	HHR08045	SLIDER KNOB, MATT BLACK	1
7	CH05010	FLUE COLLAR (5")	1
8	CH05042	FLUE COLLAR GASKET	1
9	CNS05018	DATA PLATE	1
10	HHR99990/A	FLUE COLLAR/BLANKING PLATE FIXING PACK	1
11	CH05011	BLANKING PLATE	1
12	HHR14097	COVER, TERTIARY AIR INTAKE	1
13	CH05042	BLANKING PLATE GASKET	1
14	HH06101	TERTIARY AIR BAR	1
15	HHW05063	BAFFLE, RECOUPING	1
16	CNS05007	BRICK, SIDE, WOOD (EACH)	2
17	CNS05008	BRICK, REAR, WOOD	1 (BUT SENT IN TWO PIECES)
18	HHR99985	WOOD PLUG (CAM HOLE)	1
19	CNS07014	WOOD FRONT (SINGLE DOOR)	1
19	CNS07005	LOG & CATCH BAR (DOUBLE DOOR)	1
20	HFR07040	OPERATING TOOL	1
21	FRRM06025	HINGE PIN	2
22	CH08064	HINGE	2

**CONSORT 7 - MULTIFUEL**

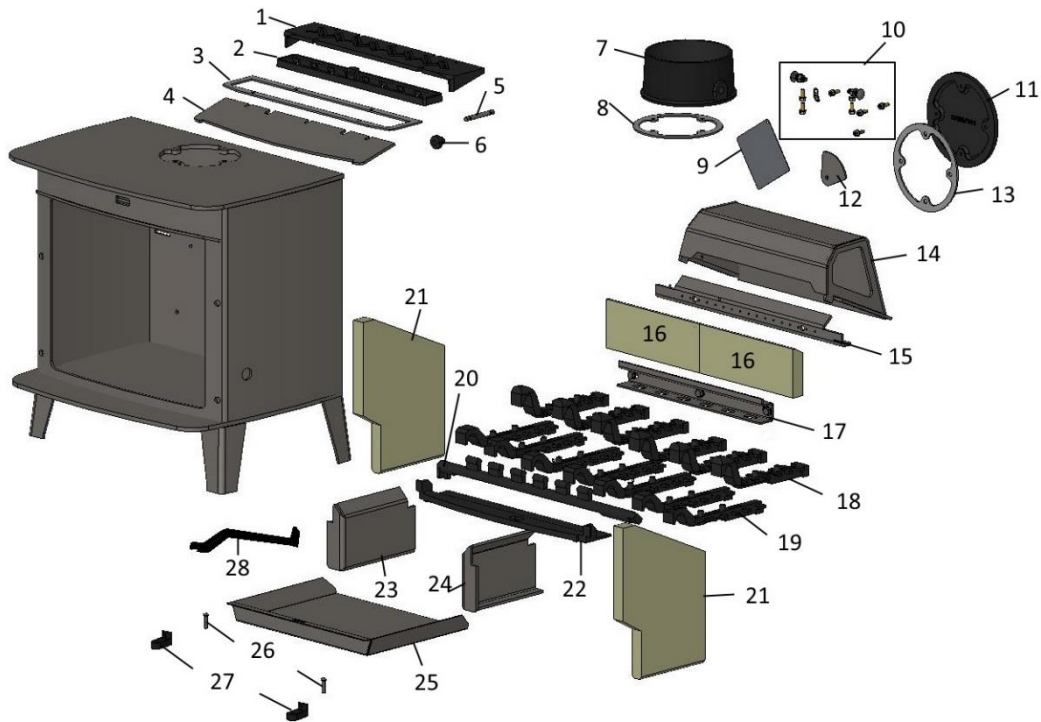



ITEM NO.	PART NUMBER	DESCRIPTION	QUANTITY
1	HH06087	PLATE, TOP AIR (BOTH DOOR TYPE)	1
2	HH06086	SLIDER, TOP AIR (BOTH DOOR TYPE)	1
3	HH06088	GASKET, TOP, AIR (BOTH DOOR TYPE)	1
4	HH06108	DEFLECTOR, TOP AIR (SINGLE DOOR)	1
4	HH06089	DEFLECTOR, TOP AIR (DOUBLE DOOR)	1
5	HCE05021	SHAFT, TOP AIR (BOTH DOOR TYPE)	1
6	HHR08045	SLIDER KNOB, MATT BLACK	1
7	CH08012	FLUE COLLAR (6")	1
8	CH08032	FLUE COLLAR GASKET	1
9	CNS07006	DATA PLATE	1
10	HHR99990/A	FLUE COLLAR/BLANKING PLATE FIXING PACK	1
11	CH08031	BLANKING PLATE	1
12	HHR14097	COVER, TERTIARY AIR INTAKE	1
13	CH08032	BLANKING PLATE GASKET	1
14	HH06131	BAFFLE, RECOUPING	1
15	HH06101	TERTIARY AIR BAR	1
16	HH06110	BRICK, REAR, MULTIFUEL	1 (BUT SENT IN TWO PIECES)
17	HH06022	REAR SUPPORT, RIDDLING BARS/REAR BRICK	1
18	CNS04013	RIDDLING BAR, UPPER	6
19	CNS04012	RIDDLING BAR, LOWER	7
20	HHR06007	CAM BAR	1
21	HH06115	BRICK, SIDE, MULTIFUEL (EACH)	2
22	CNS07004	CATCH BAR (BOTH DOOR TYPE)	1
23	HH06121B	SIDE PLATE, LH	1
24	HH06121A	SIDE PLATE, RH	1
25	HH06025	ASHPAN	1
26	FRRM06025	HINGE PIN	2
27	CH08064	HINGE	2
28	HFR07040	OPERATING TOOL	1

**CONSORT 7 – WOOD**

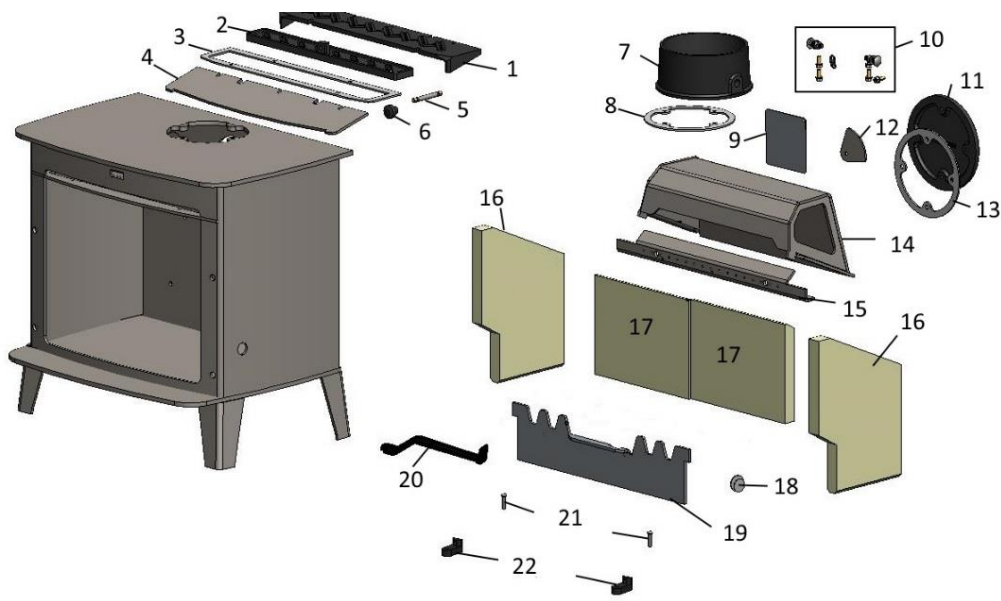

ITEM NO.	PART NUMBER	DESCRIPTION	QUANTITY
1	HH06087	PLATE, TOP AIR (BOTH DOOR TYPE)	1
2	HH06086	SLIDER, TOP AIR (BOTH DOOR TYPE)	1
3	HH06088	GASKET, TOP, AIR (BOTH DOOR TYPE)	1
4	HH06108	DEFLECTOR, TOP AIR (SINGLE DOOR)	1
4	HH06089	DEFLECTOR, TOP AIR (DOUBLE DOOR)	1
5	HCE05021	SHAFT, TOP AIR (BOTH DOOR TYPE)	1
6	HHR08045	SLIDER KNOB, MATT BLACK	1
7	CH08012	FLUE COLLAR (6")	1
8	CH08032	FLUE COLLAR GASKET	1
9	CNS07006	DATA PLATE	1
10	HHR99990/A	FLUE COLLAR/BLANKING PLATE FIXING PACK	1
11	CH08031	BLANKING PLATE	1
12	HHR14097	COVER, TERTIARY AIR INTAKE	1
13	CH08032	BLANKING PLATE GASKET	1
14	HH06131	BAFFLE, RECOUPING	1
15	HH06101	TERTIARY AIR BAR	1
16	HH06115	BRICK, SIDE, WOOD (EACH)	2
17	HH06116	BRICK, REAR, WOOD	1 (BUT SENT IN TWO PIECES)
18	HHR99985	WOOD PLUG (CAM HOLE)	1
19	CNS07014	WOOD FRONT (SINGLE DOOR)	1
19	CNS0705	LOG & CATCH BAR (DOUBLE DOOR)	1
20	HFR07040	OPERATING TOOL	1
21	FRRM06025	HINGE PIN	2
22	CH08064	HINGE	2

**CONSORT 9 SLIMLINE – MULTIFUEL**

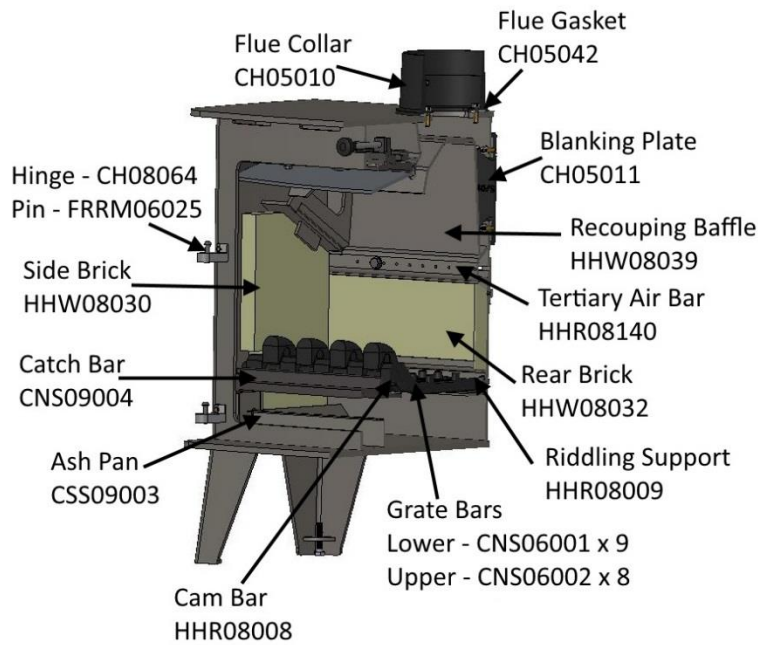

**CONSORT 9 SLIMLINE - WOOD**

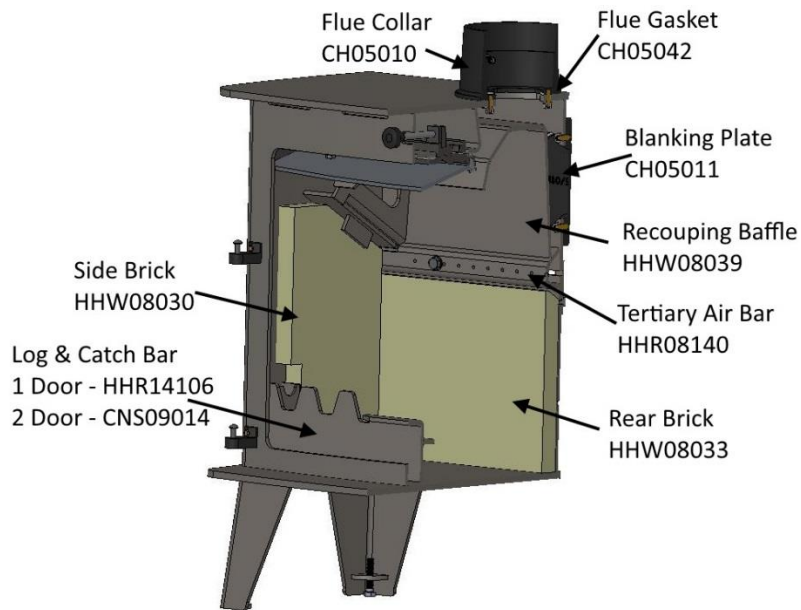

**CONSORT 9 – MULTIFUEL**

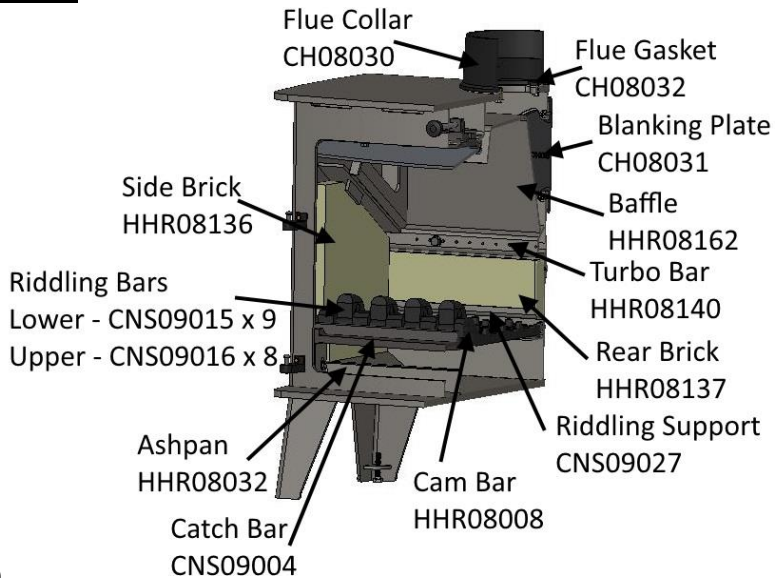

**CONSORT 9 - WOOD**

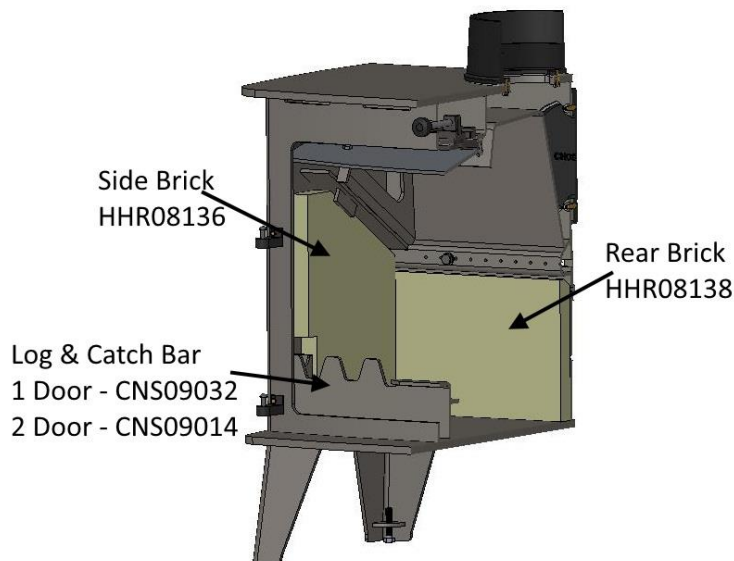

## CONSORT 15 – MULTIFUEL

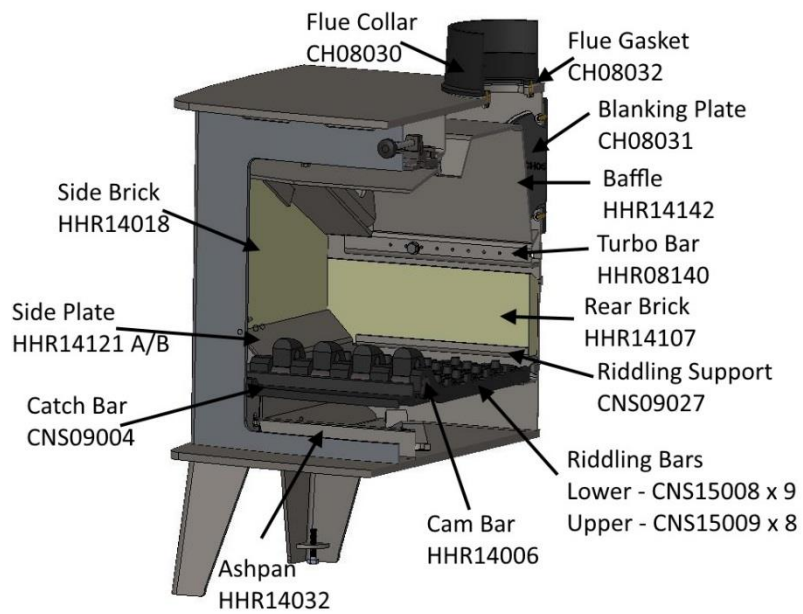

## CONSORT 15 WOOD

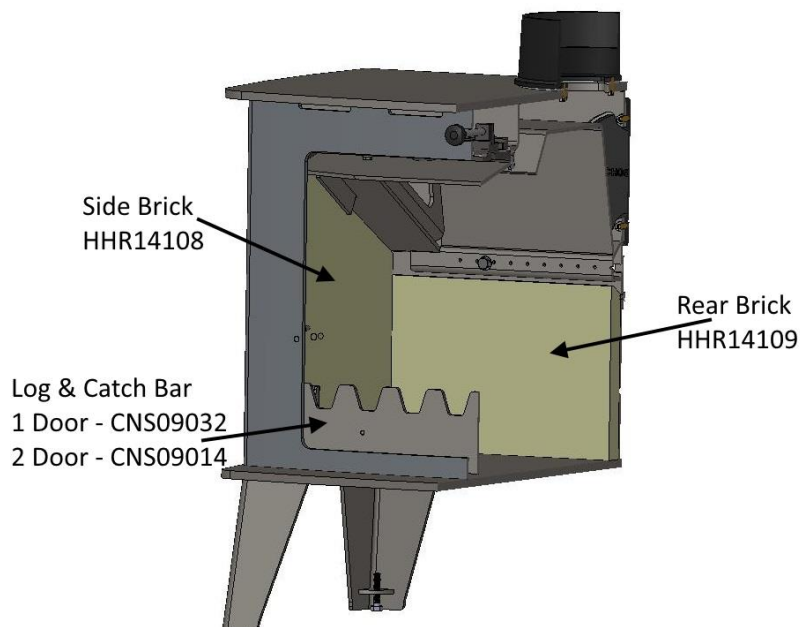

# INSTALLATION & COMMISSIONING CHECKLIST

PURCHASE INFORMATION	
Dealer/Retailer Name	
Address	
Telephone Number	
Email	
Date Purchased	

INSTALLER INFORMATION	
Installer Name	
Address	
Telephone Number	
Email	

APPLIANCE INFORMATION	
Date Installed	
Appliance Stock Code	
Appliance Description	
Serial Number	

COMMISSIONING CHECK (Complete & Sign)		
	YES	NO
Does the chimney/flue system meet the appropriate standard?		
Has the chimney/flue system been swept and passed the soundness test?		
Has this appliance passed the flue draught test?		
Please write down the flue draught reading:		
Has this appliance passed the smoke test?		
Has this appliance passed the spillage test?		
Have you explained how to operate the appliance and explained the controls?		

Signature:	Print Name:
------------	-------------

## SERVICE RECORDS

1 <sup>st</sup> Service	
Date of Service	
Date of next Service	
Servicing Company/ Engineer	
Signature	

3 <sup>rd</sup> Service	
Date of Service	
Date of next Service	
Servicing Company/ Engineer	
Signature	

5 <sup>th</sup> Service	
Date of Service	
Date of next Service	
Servicing Company/ Engineer	
Signature	

7 <sup>th</sup> Service	
Date of Service	
Date of next Service	
Servicing Company/ Engineer	
Signature	

9 <sup>th</sup> Service	
Date of Service	
Date of next Service	
Servicing Company/ Engineer	
Signature	

2 <sup>nd</sup> Service	
Date of Service	
Date of next Service	
Servicing Company/ Engineer	
Signature	

4 <sup>th</sup> Service	
Date of Service	
Date of next Service	
Servicing Company/ Engineer	
Signature	

6 <sup>th</sup> Service	
Date of Service	
Date of next Service	
Servicing Company/ Engineer	
Signature	

8 <sup>th</sup> Service	
Date of Service	
Date of next Service	
Servicing Company/ Engineer	
Signature	

10 <sup>th</sup> Service	
Date of Service	
Date of next Service	
Servicing Company/ Engineer	
Signature	



### **2 Year Standard Warranty**

Any appliance bought through the showroom of an authorised Hunter Stoves Group dealership will automatically be covered by our standard 2-year conditional guarantee.

However, this standard 2-year warranty can be extended to a **5 year** or **10-year** conditional warranty dependent on the model type (5 years- Boiler model and Gas models, 10 years- Room heater).

To qualify for this extended warranty option, you need to:

1. Register your purchase online at <https://www.hunterstoves.co.uk/ProductRegistration>
2. Retain your proof of purchase.

### **Warranty Conditions**

For the Standard 2 year or extended 5/10-year warranty to be valid and to remain in force throughout the warranty period the following must have been carried out:

1. The appliance must have been installed by an appropriately qualified engineer (from the Competent Person Scheme/Gas Safe) in accordance with the manufacturer's instructions and in compliance of any relevant national or local building regulations. Please visit the following links for details on the Competent Person Scheme: <https://www.gov.uk/guidance/competent-person-scheme-current-schemes-and-how-schemes-are-authorised> and Gas Safe register: <https://www.gassaferegister.co.uk/>
2. The appliance will need to be registered within two months of purchase and the commissioning and installation documentation completed (these need to be kept by the end user).
3. The appliance must be serviced within 12 months of the installation date for the second year of the standard warranty to be valid, and within every 12-month anniversary thereafter to maintain the validity and coverage of any extended warranty. For this purpose, the installation and user instructions, supplied with the appliance, makes a provision for receipts and annual services to be recorded. This is needed in the event of a claim during the warranty period.
4. Only genuine Hunter Stoves spare parts or consumables can be used in the servicing and maintenance of the appliance during any standard or extended warranty period. These can be sourced from your authorised supplier directly or through our website spares portal. [www.hunterstoves.co.uk/spares](http://www.hunterstoves.co.uk/spares).
5. Any problems or issues giving rise to any claim under the standard or extended warranty must be submitted to the authorised Hunter Stoves Group retailer from whom you originally purchased the appliance. Hunter Stoves Group will then offer appropriate support and help through your original authorised supplier to solve any issues.
6. The standard or extended warranty option is not transferable. It is solely for the benefit of the original purchaser of the appliance. For this purpose, please retain the proof of purchase.

### **Warranty Exclusions**

No warranty period is extended to naturally-wearing replaceable consumables and spare parts within the appliance. Such parts include, but are not limited to:

#### **For Solid Fuel Stoves:**

Glass and rope/ceramic seals  
Fire bricks  
Baffles/Throat plates  
Log retainers, grate supports & catch bars  
Grate parts  
Ash-pans  
Clip-in Boilers

#### **For Gas Stoves:**

Gas pilot assemblies  
Thermocouples and Oxy pilots  
Ceramic log & coal 'fuel -effects'  
Batteries

## **Paint and Surface Coverings**

The paint or surface covering of the appliance will be covered (for 2 years after installation) provided the warranty conditions are met. However, damage due to the following events will not be covered:

1. Damage to the paint surface caused by the appliance being stored in a damp and cold environment is not covered under warranty. Please be aware that any moisture within the room where the stove is installed e.g. through clothes drying, can be a cause of paint issues.
2. In the course of the initial firings of the appliance the paint or enamel surface may change colour. This is normal and as such is therefore not covered under warranty.
3. Damaged caused by over firing, resulting in cracking, bubbling or discolouration to the paint or enamelled surface finish is not covered under warranty.

## **Warranty Limitations**

1. Damage to the appliance due to specific local conditions caused by draft or chimney defects.
2. Damage resulting from installation and use where installation is not in accordance with the manufacturer's instructions or local building and/or safety regulations.
3. Damage or premature wear caused by burning inappropriate fuels such as Bituminous coal, "Petro-Coke" or any other Petroleum based coals. Please visit the HETAS website, [www.hetas.co.uk](http://www.hetas.co.uk), for a full list of approved fuels which are covered by the warranty. Fuels outside of this list are not covered by the warranty.
4. Damage caused by burning material with high creosote content or any other painted/treated timber.
5. Consequential loss to associated non-Hunter Stoves Group products is not covered under the warranty.
6. Consequential loss relating to decorations, soft furnishings or other household assets is not covered under the warranty.
7. Cost associated with the removal and re-installation of an appliance subject to a warranty claim.

Hunter Stoves Group total liability will only extend to the total purchase price paid for the goods in any warranty claim. Hunter Stoves Group reserve the right to replace, repair or refund to value of goods purchased.

**ANY HUNTERS STOVES GROUP PRODUCT PURCHASED VIA AN INTERNET SUPPLIER, OR THROUGH AN UNAUTHORISED STOCKIST WILL ONLY BE SUPPORTED BY THE STATUTORY, 12 MONTH GUARANTEE AND WILL NOT QUALIFY FOR ANY EXTENDED 5 OR 10 YEAR WARRANTY.**

The Hunter Stoves Group extended warranty option does not affect your statutory rights.

This revised standard or extended 5 or 10-year warranty option comes into effect on **1<sup>st</sup> September 2015** and will apply to all appliances sold from that date.

This standard/extended warranty applies to purchases of Hunter Stoves within the United Kingdom and the Republic of Ireland. Purchases in all other countries are subject to the warranty conditions specified by the distributor in those markets.



hunterstoves  
GROUP

Hunter Stoves Ltd, 8 Emperor Way, Exeter Business Park, Exeter, Devon, EX1 3QS  
[www.hunterstoves.co.uk](http://www.hunterstoves.co.uk) Email : [info@hunterstoves.co.uk](mailto:info@hunterstoves.co.uk)

## **Further Information**

For extra guidance on using your stove, please visit our YouTube channel by searching 'Hunter Stoves Group' or see the helpful hints section of our website; [www.hunterstoves.co.uk](http://www.hunterstoves.co.uk).

This appliance is suitable for intermittent burning.

This appliance should not be used in a shared flue.

All genuine Hunter Group spares can be purchased through our website [www.hunterstoves.co.uk/spares](http://www.hunterstoves.co.uk/spares) or through your authorised dealer.