



# CONSORT 9 AND 15 MULTIFUEL CENTRAL-HEATING CE VII MODEL

Instructions for:  
Installation/Operating/Maintenance/Serviceing  
JINWCN0915 REV C 06/06/2019

# STOVE MODELS



## CONSORT 9 BOILER

CVWCN09FM/CVWSCN09FM  
CVWCN09FW/CVWSCN09FW



## CONSORT 15 BOILER

CVWCN15FM/CVWSCN15FM  
CVWCN14FW/CVWSCN15FW







Welcome to the Hunter Stoves family and thank you for purchasing a Parkray Consort stove. This stove was designed and built to be a high-performance heating appliance, and we hope it will bring you great enjoyment. The natural environment is important to us, so our stoves are manufactured to provide you with a clean and efficient burn that will keep you warm through cold winter nights.

#### CONTENTS INDEX:

STOVE MODELS.....	2
TECHNICAL SPECIFICATION.....	4
IMPORTANT INFORMATION.....	5
SAFETY.....	6
REMOVE INTERNAL COMPONENTS.....	7/8
APPLIANCE DIMENSIONS.....	9
PRE INSTALLATION REQUIREMENTS.....	9/10
LEGAL REQUIREMENTS.....	10/11
CLEARANCES.....	11/12
INSTALLATION OF BOILER MODELS.....	12 - 14
COMMISSIONING AND HANDOVER.....	14/15
OPERATING INSTRUCTIONS.....	15-18
MAINTENANCE & SERVICING.....	18/19
TROUBLESHOOTING.....	20/21
OPTIONAL EXTRAS.....	22
SPARES.....	22 - 25
INSTALLATION & COMMISSIONING CHECK LIST.....	26
SERVICE RECORDS.....	27
FULL WARRANTY INFORMATION.....	28/29

## Technical Specification

	 <b>PARKRAY</b> <small>THE FIRST NAME IN SOLID FUEL</small>		<b>Consort 9</b>	<b>Consort 15</b>
<b>GENERAL</b>	Energy Efficiency Class		<b>A</b> 	<b>A</b> 
	Nominal Heat Output	Wood	8.6kW	13.9kW
	Nominal Heat Output	Ancit	8.0kW	14.3kW
	Energy Efficiency	EEL	97	98
	Output to Water	Wood	6.4kW	9.1kW
	Output to Water	Ancit	6.3kW	9.5kW
	Output to Room	Wood	2.2kW	4.8kW
	Output to Room	Ancit	1.7kW	4.8kW
	Efficiency	Wood	73.4%	73.6%
	Efficiency	Ancit	71.4%	71.1%
	Mean CO (@13% O <sub>2</sub> )	Wood	0.51%	0.50%
	Mean CO (@13% O <sub>2</sub> )	Ancit	0.30%	0.31%
	Appliance Mass		133kg	163kg
	Recommended Fuels	Wood	Seasoned Wood (less than 20% moisture content)	
		Smokeless Fuel	Anthracite or a manufactured briquette smokeless fuel which is suitable for closed door appliances.	
	Log Length		500mm	500mm
<b>FLUES</b>	Mean Flue Gas Temperature	Wood	283°C	344°C
	Mean Flue Gas Temperature	Ancit	257°C	347°C
	Flue Gas Mass Flow	Wood	8.9 g/s	11.0 g/s
	Flue Gas Mass Flow	Ancit	9.8 g/s	12.5 g/s
	Flue Outlet Size (Top or Rear Option)		150mm	150mm
<b>VENTILATION</b>	<ul style="list-style-type: none"> <li>- Where leakage is greater than 5m<sup>3</sup>/hour/m<sup>2</sup></li> <li>- Ventilation normally required = 550mm<sup>2</sup> per kW output over 5kW</li> </ul>		1980mm <sup>2</sup>	5115mm <sup>2</sup>
	<ul style="list-style-type: none"> <li>- Where leakage is less than or equal to 5m<sup>3</sup>/hour/m<sup>2</sup></li> <li>- Ventilation normally required = 550mm<sup>2</sup> per kW output</li> </ul>		4730mm <sup>2</sup>	7865mm <sup>2</sup>

For further information on ventilation please refer to Building Regulations Document J or your installer.

# IMPORTANT INFORMATION

**PLEASE READ THESE INSTRUCTIONS PRIOR TO INSTALLATION AND OPERATION. KEEP THESE INSTRUCTIONS IN A SAFE PLACE FOR FUTURE REFERENCE AND SERVICING.**

**THIS APPLIANCE WILL BECOME VERY HOT WHEN USED IN ACCORDANCE WITH THESE INSTRUCTIONS, HUNTER STOVES RECOMMEND THAT AN APPROVED GUARD IS USED TO PROTECT THE YOUNG, ELDERLY OR INFIRM FROM HARM.**

**THE INSTALLER COMMISSIONING SHEET CAN BE FOUND ON THE BACK COVER. PLEASE ENSURE THAT IT IS COMPLETED PRIOR TO USE.**

## **General Guidance**

It is important that your stove is correctly installed and operated as Hunter Stoves Group cannot accept responsibility for any fault arising through incorrect installation, use, maintenance or servicing.

These instructions cover the basic principles to ensure satisfactory installation of the stove, although detail may need slight modification to suit particular local site conditions.

The installation must comply with current Building Regulations, National and European Standards, Local Authority Byelaws and other specifications or regulations as they affect the installation of the appliance.

The Building Regulations requirements may also be met by adopting the relevant recommendations in the current issues of British Standards BS 8303 and BS EN 15287-1.

Only use approved fuels on this appliance. Information about this can be found on Page 18.

This is a Domestic Appliance and must only be used in accordance with these instructions. Do not place articles that are affected by high temperatures on, or near, this appliance. Do not place furniture or other items within 1 metre of the front of this appliance. See the note on material clearances on pages 11/12.

Fitting a stove in a room which also contains an extractor fan and/or cooker hood should be avoided where possible. If this is unavoidable, the suitability of the space for fitting this appliance must be decided at the discretion of a qualified installer, and a flue draught interference test must be performed.

Do not obstruct the ventilation required for the safe use of this appliance.

### **Competent Persons Scheme**

Hunter Stoves Group recommend that this stove is installed by a member of an accredited competent persons scheme e.g. HETAS.

If the installer is not a member of a competent person's scheme, it is a legal requirement, in the UK, to notify your Local Building Control Officer in advance of any installation work starting.

### **Health and Safety Precautions**

Special care must be taken when installing the stove such that the requirements of the Health and Safety at Work Act are met.

### **Handling**

This appliance is very heavy. Adequate facilities must be available for loading, unloading and site handling.

### **Fire Cement**

Some types of fire cement are caustic and should not be allowed to come into contact with the skin. In case of contact, wash immediately with plenty of water.

### **Asbestos**

This stove contains no asbestos. If there is a possibility of disturbing any asbestos in the course of installation, then please seek specialist guidance and use appropriate protective equipment.

### **Metal Parts**

When installing or servicing this stove, care should be taken to avoid the possibility of personal injury.

### **Modification**

No unauthorised modification of this appliance should be carried out.

# **Safety**

**WARNING** – This appliance will be hot when in operation and due care should be taken. The supplied operating tool or glove may be used to open the door and operate the air controls.

## **Aerosols**

Do not use an aerosol spray on or near the stove when it is alight.

## **Fireguards**

Always use a fireguard in the presence of children, the elderly or the infirm. The fireguard should be manufactured in accordance with BS8423 – Fireguards for use with solid fuel appliances.

## **Do not Over-Fire**

It is possible to fire the stove beyond its design capacity. This could damage the stove so watch for signs of over-firing. If any part of the stove starts to glow red, the stove is in an over-fire situation and the controls should be adjusted accordingly.

Never leave the stove unattended for long periods without first adjusting the controls to a safe setting. Careful air supply control should be exercised at all times.

## **Fume Emission**

Properly installed, operated, this appliance will not emit fumes. Occasional fumes from de-ashing and refuelling may occur. Persistent fume emission must not be tolerated.

***This appliance should not be operated with the door open.***

If fume emission persists, then the following immediate action should be taken: -

- Open doors and windows to ventilate the room.
- Let the fire go out or eject and safely dispose of fuel from the appliance.
- Check for flue/chimney blockage and clean if required.
- Do not attempt to re-light the fire until the cause of the fume emission has been identified and corrected.

If necessary, seek expert advice.

## **Adverse Weather**

In a small number of installations, occasional local weather conditions (e.g. wind from a particular direction) may cause downdraught in the flue and cause the stove to emit fumes. In these circumstances, the stove should not be used. A professional flue installer will be able to advise on solutions to this problem (e.g. anti-downdraught cowl).

## **Carbon Monoxide Detector**

Hunter Stoves recommend a Carbon Monoxide Detector that conforms to the latest issue of BS EN 50292 is placed in the same room as the appliance. The installation of such an alarm is not considered as a substitute for regular maintenance or servicing of the appliance and Flue system.

## **IN THE EVENT OF A CHIMNEY FIRE:**

- Raise the alarm
- Call the Fire Brigade
- Close appliance air controls
- Move furniture, ornaments etc. away
- Place a fireguard in front of stove
- Check the chimney breast for signs of excessive heat.

If the wall is becoming excessively hot, move furniture away.

Ensure the Fire Brigade can gain access to your roof space in order to check for fire spread.

## Removing Internal Components

All internal components must be removed prior to fitting the stove. This will make handling the stove easier; allow access to fixings and the flue outlet; as well as protect the internal components from damage during the installation process.

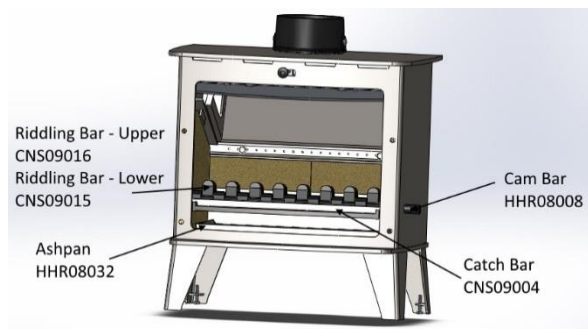

1. Open the door and remove the ashpan.
2. Remove the grate bars by lifting the front up off the cam bar and sliding forward off the rear grate support and lift out of the firebox.
3. Remove the cam bar by lifting the left-hand end of it upwards until it clears the side casting. Pull the left-hand end towards the front of the stove and then slide all the way out. Take care not to lose the cam hole plate.
4. Remove the catch bar by lifting upwards and pulling forwards out of the stove body.

### Side Plates

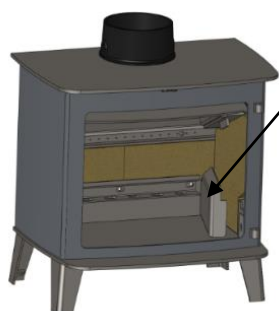

Slide out both Side Plates.  
(Consort 15 MF only)

### Side Bricks

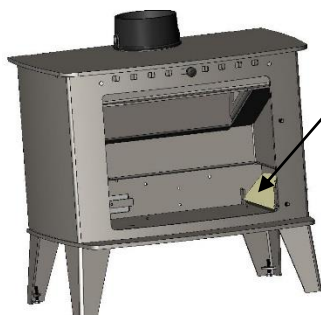

Slide the base of the Side Brick towards the centre of the stove and remove.  
(Not Consort 15 MF)

### Baffle/Throat Plate



Lift the Baffle and slide to the right. When the left side of the Baffle clears the support, lower into the Firebox and remove.

# Stove Assembly

## Flue Collar/Blanking Plate

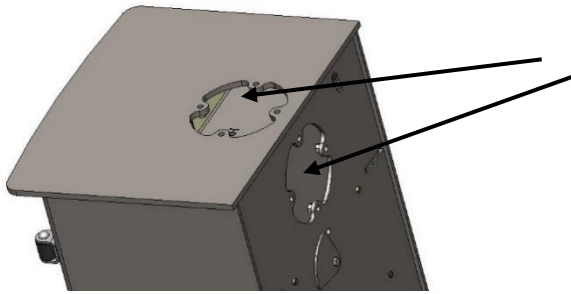

Top or rear outlet

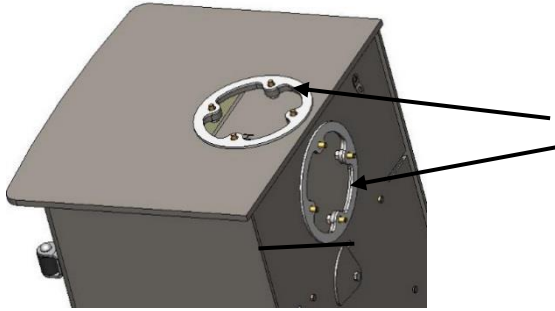

Place the flue collar gasket on the outlet to be used.

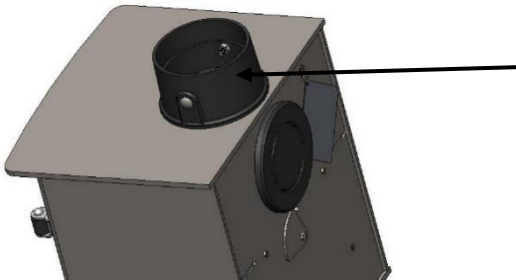

Wind the four M6 studs supplied into the fixing holes in the flue collar until finger tight. Place the flue collar onto the stove and tighten using the supplied washers and nuts from inside the stove.

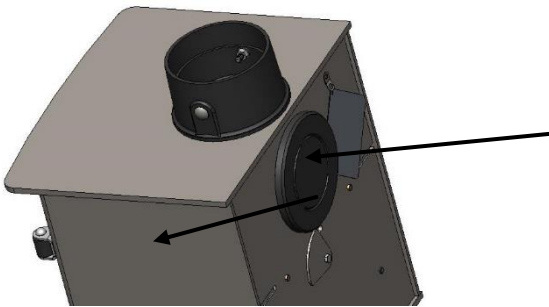

Place the gasket on the outlet and put the blanking plate on top of this. Wind the four M6 studs supplied into the fixing holes until finger tight. Place the plate onto the stove and tighten using the supplied washers and nuts from inside the stove.

## Re-Assembling The Stove

Refit all the internal parts by following the 'removing internal component' instructions in reverse order.



## Appliance Dimensions

### CONSORT 9 BOILER

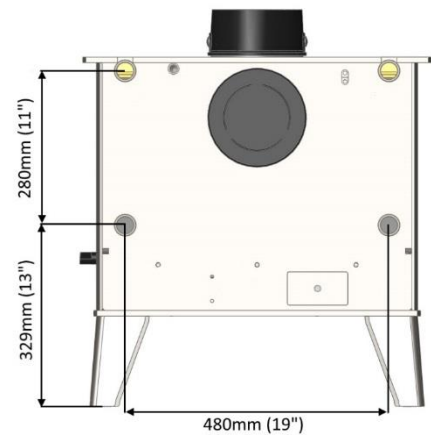
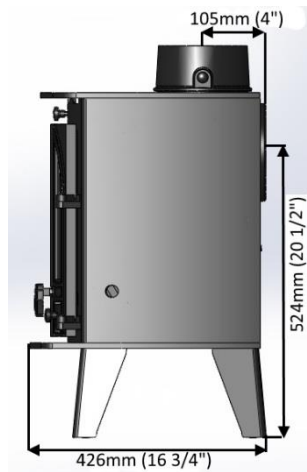

### CONSORT 15 BOILER

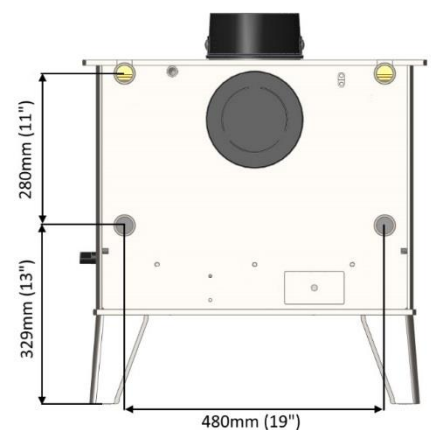
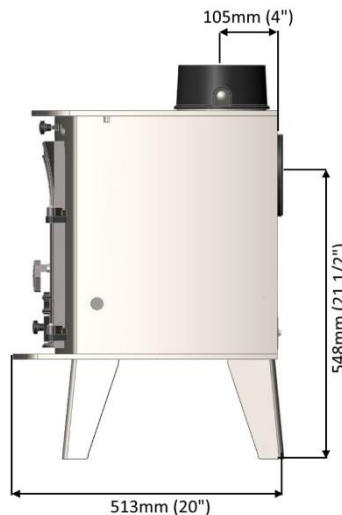
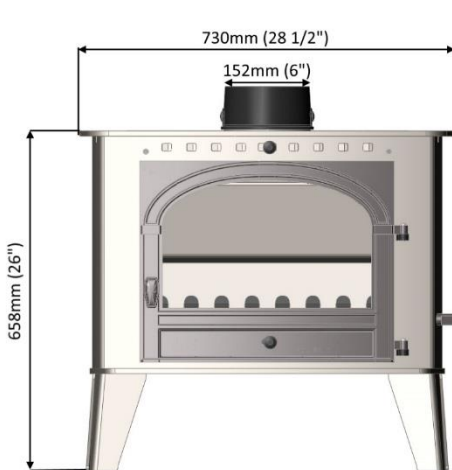

## Pre-Installation Requirements

### PLEASE CHECK THE FOLLOWING:

Any existing chimney/flue system must be confirmed as suitable for this appliance as defined in Building Regulations Document J. It must be swept and inspected, by a competent person (see notes), to confirm that is structurally sound and free from cracks

The diameter of the Flue should not be less than  $\varnothing 150\text{mm}$  and not more than  $\varnothing 230\text{mm}$ . Do not connect to systems that have large voids or spaces. If any of these requirements are not met, the chimney should be lined by a suitable method.

If the chimney is suspected of previously serving an open fire it must be swept again, within a month of regular use, to clear any soot that may have been dislodged due to the variation in combustion levels and higher flue gas temperature levels. The chimney/flue system exit must comply with Building Regulations Document J. The minimum height and should terminate in accordance with Table 1.

## Connection to the Chimney

An existing fireplace opening can be bricked up or sealed with a register plate. A short length of flue pipe of minimum 152mm internal diameter may then be used to connect the stove to the chimney. This flue pipe should be made of 316 grade stainless steel or vitreous enamelled steel, nominal thickness 1.2mm. Ensure that the pipe end is no closer than 76mm to the chimney walls. The length of any horizontal run of flue pipe must not exceed 152mm. It is essential that all connections between the stove and chimney-flue are sealed and made airtight.

Make provision to access the chimney/flue system for cleaning and the removal of debris. If there is no existing chimney then either a prefabricated block chimney in accordance with Building Regulations Approved Document J, or a twin-walled insulated stainless-steel flue to BS4543 can be used. These chimneys must be fitted in accordance with the manufacturer's instructions and Building Regulations. New masonry and flue block chimneys must meet the requirements of Building Regulations Document J. Any connecting flue pipe systems must also meet these regulations.

Please check the suitability of the fireplace and/or surround for use with this appliance before installing it. If you have any doubts about the suitability of your chimney, consult your local Dealer/Stockist or Installation Engineer. Both the chimney and flue pipe must be accessible for cleaning and if ANY part of the chimney cannot be reached through the stove (with baffle removed), a soot door must be fitted in a suitable position.

### Flue Outlet Positions (Document J):

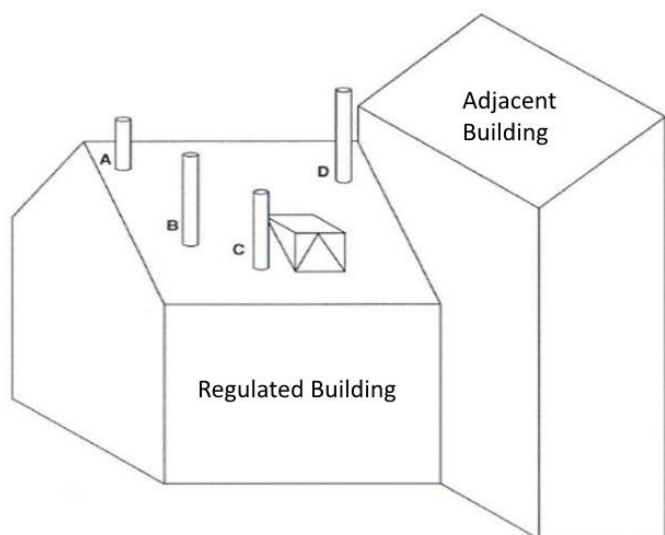

	Position on Roof	Clearances to flue exit
A	At or within 600mm of the ridge	At least 600mm above the ridge
B	Elsewhere on a roof (Pitched or Flat)	At least 2.3 M horizontally from the nearest point on the weather surface and: a) At least 1.0 M above the highest point of intersection between the chimney and weather surface; or b) at least as high as the ridge
C	Below (on a pitched roof) or within 2.3 M horizontally to an opening window or dormer	At least 1.0 M above the top of the opening
D	Within 2.3 M of an adjoining or adjacent building, whether or not beyond the boundary	At least 600mm above any part of the adjacent building within 2.3 M

A full copy of Document J can be found here:

Table 1

[http://www.planningportal.gov.uk/uploads/br/BR\\_PDF\\_ADJ\\_2010.pdf](http://www.planningportal.gov.uk/uploads/br/BR_PDF_ADJ_2010.pdf)

### Legal Requirements

Hunter Stoves Group requests that before installation and/or use of this appliance that you read these instructions carefully to ensure that all the relevant requirements are fully understood.

These instructions cover the basic principles to ensure satisfactory installation of the stove, although detail may need slight modification to suit particular local site conditions. In all cases the installation must comply with current Building Regulations, Local Authority Byelaws, European and National Standards and other specifications or regulations as they affect the installation of the stove.

It should be noted that the Building Regulations requirements may be met by adopting the relevant recommendations given in British Standards BS 8303, BS 6461 and BS 7566 as an alternative means to achieve an equivalent level of performance to that obtained following the guidance given in Approved Document J.

Your local Building Control Officer can advise you regarding the interpretation of the Regulations should there be any questions.

This appliance must be installed by a Registered Installer (see Competent Persons Scheme) or approved by your local Building Control Officer.

All works undertaken must be carried out with due care and attention to meet the requirements of the Health & Safety code of practice and any other legislation that may have been introduced since the publication of these instructions.

### **Competent Persons Scheme**

Members of the following schemes may self-certify the installation of this stove. If the installer is not a member of one of these schemes, your local Building Control Department must approve the installation.

<b>Scheme</b>	<b>Web address</b>	<b>Telephone</b>
APHC (Association of Plumbing and Heating Contractors (Certification) Limited)	<a href="http://www.aphc.co.uk">www.aphc.co.uk</a>	02476 470 626
Building Engineering Services Competence Accreditation (BESCA Limited)	<a href="http://www.hvca.org.uk">www.hvca.org.uk</a> / <a href="http://www.besca.org.uk">www.besca.org.uk</a>	0800 652 5533
HETAS Ltd (Heating Equipment Testing and Approval Scheme)	<a href="http://www.hetas.co.uk">www.hetas.co.uk</a>	01462 634721
NAPIT Registration Ltd	<a href="http://www.napit.org.uk">www.napit.org.uk</a>	0870 444 1392
NICEIC Group Ltd	<a href="http://www.niceic.org.uk">www.niceic.org.uk</a>	0800 013 0900

### **Air Supply**

The room or space containing this appliance needs a permanent, unobstructed air opening of at least 1980mm<sup>2</sup> (Consort 9), 5115mm<sup>2</sup> (Consort 15) (see Technical Specification on Page 3 for confirmation).

If a draught stabiliser is fitted, the air opening should be at least 4560mm<sup>2</sup> (Consort 9) 9405mm<sup>2</sup> (Consort 15).

Due consideration should be given to air requirements for any other appliance in the same room or space.

Any air opening must be kept clear from blockage or obstruction.

### **Hearth/ Material Clearances**

Hearth constructions must comply with the current building regulations.

Your stove must be installed on a floor with adequate load-bearing capacity, otherwise suitable measures should be taken.

If the existing construction does not meet this pre-requisite, suitable measures (e.g. load distributing plate).

Care should be taken to level the stove using the adjusting screws in the feet.

### **Material Clearances**

<b>Minimum Distances to Combustible Material</b>	<b>Consort 9</b>	<b>Consort 15</b>
<b>Behind the stove</b>	250mm	150mm
<b>At the side of the stove</b>	150mm	150mm
<b>In front of the stove</b>	900mm	900mm

Note: combustible material refers to any material that will degrade when subjected to heat e.g. plaster.

No combustible material must be stored underneath the stove.

## Non Combustible - Fireplace Recess

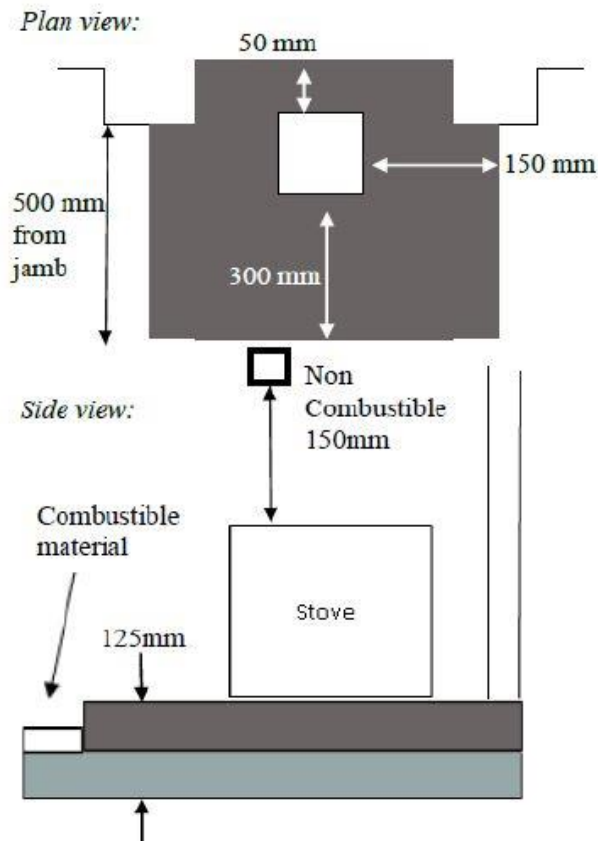

The stove can be recessed in a suitable sized fireplace but a permanent free air gap of at least 150mm on top and 50mm at the sides (although we recommend 150mm) and 50mm at the back of the stove to obtain maximum heat output and for access to the rear of the stove.

The hearth should extend at least 300 mm from the front of the stove. The stove should stand wholly above a solid, non-combustible hearth, at least 125 mm thick (this may include the thickness of a solid floor and a non-combustible decorative hearth).

## Installation Of Boiler Models

We strongly recommend that a knowledgeable, experienced and qualified plumbing and heating engineer is responsible for the design and installation of the heating and hot water system. Hunter Stoves Ltd cannot accept responsibility for any consequential loss, however caused, due to under or over specification of the appliance in any installation.

**Do Not** – Under any circumstances connect the stove to a sealed (pressurised) heating system or unvented hot water cylinder.

**Do Not** – Link the stove into a heating or hot water system with an existing boiler without the use of suitable equipment such as a neutralizer. When fitting this type of system, the neutraliser manufacturer's instructions must be followed.

**Do** – Fit an open cold feed and expansion cistern with separate cold feed and vent pipes. The cold feed and vent pipes must be unvalved. The open vent pipe should have a diameter of 22mm and rise continuously from the boiler. It is common practice to form the vent pipe from an extension of the primary flow (see diagram).

**Do** – Connect the stove to a **double feed, indirect** hot water cylinder via 28mm copper flow and return pipework, rising continuously from the boiler to the cylinder. The cylinder and heat leak radiator must be sited higher than the stove.

Semi pumped systems should be used on heating and hot water systems with gravity circulation to the hot water cylinder and one unvalved 2 KW radiator to act as a heat leak when the central heating is switched off.

All four tappings on wraparound boilers should be used for systems incorporating separate gravity and pumped heating loops. Each flow and return should be taken from diagonally opposite sides of the boiler.

If a common flow and return is used, these should also be taken from diagonally opposite sides of a wraparound boiler, and plugs inserted into the sockets not used.

Systems using a common flow and return to the boiler should incorporate an injector tee on the primary return connection from the central heating pump (see diagram).

A HIGH LIMIT thermostat should be fitted to the gravity flow pipe close to the boiler and set at 90°C. This should override any pump control, switching the pump on and dissipating any excess heat around the radiator circuit.

To prevent boiler corrosion due to condensation it is necessary to maintain the return water temperature above 45°C. This can be achieved by the use of a LOW LIMIT thermostat on the return pipe from the hot water cylinder, close to the boiler. The thermostat should make on temperature rise, preventing the circulating pump from operating until the gravity circuit is up to temperature.

A corrosion inhibitor should be added to the system to ensure satisfactory performance and long system life.

**Wiring Diagram for general guidance only**

All electrical work must be carried out by a competent electrician in accordance with the rules in force and the instructions provided by the circulating pump and heating controls manufacturer.

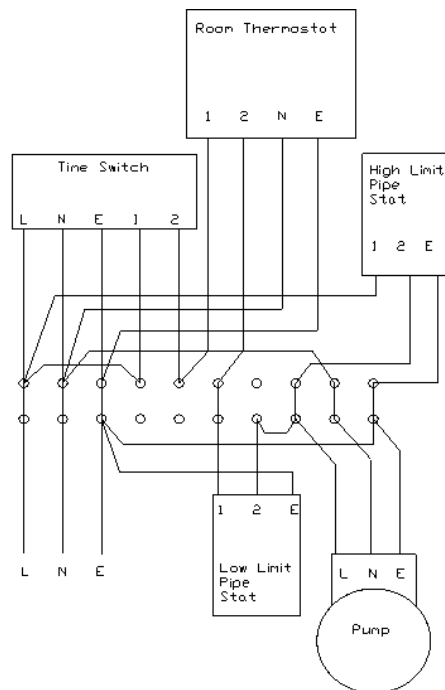

**Four Tapping System**

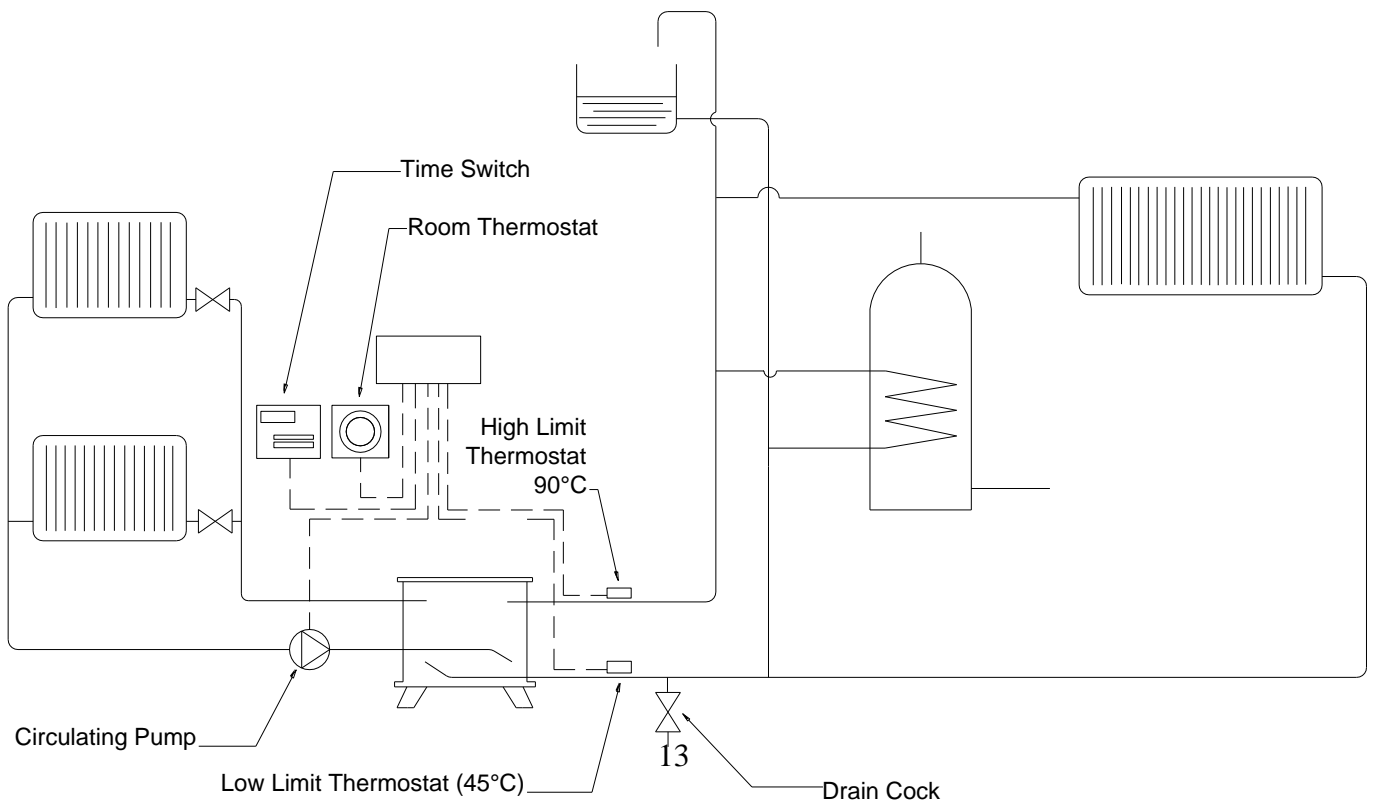

## Two Tapping System

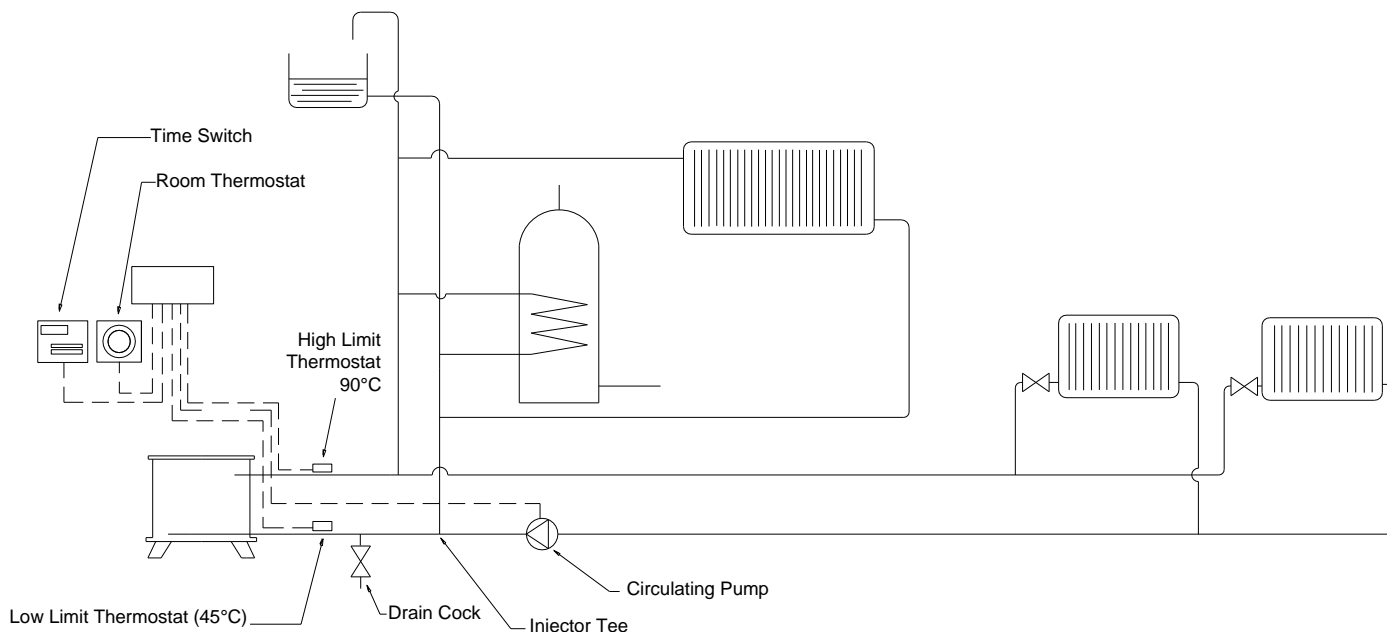

## Commissioning & Handover

### Appliance Check

Please check that all components are correctly assembled and working correctly.

Ensure the Air Controls are working correctly.

Hunter Stoves Group recommend that you carry out a smoke draw test to check the soundness of the chimney/flue system and seals:

Place a Smoke Pellet in the centre of the Grate, ensure that all of the Air Controls are fully open and close the Door.

The smoke should now be drawn up the chimney and you should be able to see it exit from the chimney/flue terminal.

We recommend that you do this test with all of the windows and doors, to the room where the appliance is fitted, closed.

If there any adjoining room(s) that have an Extractor Fan fitted, open the adjoining door to ensure that the chimney/flue system is not compromised when the fan is operating. If there is a ceiling fan fitted in the room, please operate it and ensure that it does not affect the operation of the chimney/flue system.

**If any of these tests fail, please re-check the suitability of the chimney/flue system together with the ventilation.**

A small fire can now be lit and allow the appliance to heat up slowly ensuring that no products of combustion enter into the room.

Carry out a spillage test using a smoke match around the door opening.

If there is excessive spillage, please allow the appliance to cool and then re-check the chimney/flue system and ventilation.

Do not run the stove at full output for at least 24 hours.

On completion of the commissioning:

Upon completion, allow a suitable period of time for any fire cement and mortar to dry out. Please instruct the user on the safe operation of this appliance, how the controls work and basic maintenance requirements.

Ensure that the operating instructions and appliance tools are left with the customer and the check lists have been filled out correctly.

Please advise the customer on the correct use of the appliance with the fuels likely to be used on the stove and warn them to use only the recommended fuels for the stove.

Advise the user on what to do should smoke or fumes be emitted from the stove.

The user should be warned to use a fireguard to BS 8423 in the presence of children, aged and/or infirm persons.

Hunter Stoves Group also recommend that a CO alarm is fitted into the room where the appliance is located.

### **FLUE DRAUGHT**

If the draught exceeds the recommended maximum, a draught stabiliser must be fitted so that the rate of burning can be controlled and to prevent over firing.

If the reading is less than the recommended minimum, then the performance of the appliance will be compromised. The flue draught should be checked under fire at high output with windows and doors closed. To take the reading remove one of the coach bolts in the flue collar and put the probe in the hole.

**Minimum Draught – 1.2mm Water Gauge**

**Maximum Draught – 2.5mm Water Gauge**

## **Operating Instructions**

*Read the 'General Guidance' Section at the start of these instructions before operating your stove for the first time.*

*Allow sufficient clearance between the stove and pictures, plasma screen televisions or ornaments etc., as these could be damaged and could potentially create a fire hazard (For more information read the 'Material Clearance' section of these installation instructions).*

**WARNING – This appliance will be hot when in operation and due care should be taken. The supplied operating tool or gloves may be used to open the door and operate the air controls.**

### **Please Note**

Your Building Insurance Company may require you to inform them of this new installation and that the work has been carried out correctly. Please check your policy to ensure that it is still valid when this installation is complete.

### **Using The Appliance For The First Time**

#### **SAFETY ADVICE**

During the first operation it is highly likely that fumes and smells maybe produced as part of the normal heat resistant paint curing process, much like a domestic oven. Therefore, good ventilation during this process is of utmost importance. We recommend that pregnant women, allergic persons and small children as well as domestic animals, especially birds, should not unnecessarily stay in subjected areas.

When being heated up for the first time, smells and fumes are often produced. This is a normal chemical process that allows the specialist heat resistant paint to cure and harden.

Please arrange for good ventilation of the room. Open windows and doors and if necessary, use a ventilator for fast interchange of air. Heat up to operation temperature for at least one hour. If maximum temperature is not achieved after heating up, release of odour may appear later.

### **Aerosols**

**Do not use an aerosol spray on or near the stove when it is alight.**

### **Air Control**

This stove has been designed to burn far more efficiently than a traditional stove if used correctly, with the obvious notable feature of CLEAN GLASS. It is essential that the stove has an adequate air supply for combustion and ventilation. The primary and secondary air inlets must be kept clear from obstruction and blockage.

## **Primary Air**

This provides a conventional air draught to the bed of the fire.

The sliders in each door (double door) or one slider (single door) open when moved to the right. They close when moved to the left.



## **Secondary Air**

Secondary air is controlled via the slider above the door; it is this “Airwash” that keeps a clean and uninterrupted view of the fire. The amount of air can be increased by moving the slider to the right.



Warning! – This Appliance will be hot when in operation and due care should be taken.

We advise that suitable gloves are used when operating the air control, and when opening the door.

## **Lighting the Stove**

To light the stove, open the primary and secondary air controls fully.

Light one or two firelighters placed centrally on the grate, allowing the flames to become established before placing several pieces of small dry kindling in a criss-cross fashion above the firelighters, taking care not to smother the fire. Close the stove door. Once the kindling is well alight open the door and build the fire by gradually adding slightly larger pieces of wood, closing the door afterwards.

Once you have a good fire established across the grate bed, further fuel can be added as required and the air controls set to the correct position.

Should the fire fail to light correctly open the door and use a poker to spread the fuel across the grate. Close the door and allow the fuel and stove to cool before attempting to relight the fire.

## **Locomotive Grate**

### **Grate Operation & Burning Wood**

Your Consort 9 and 15 are fitted with a locomotive type grate. So that de-ashing can be carried out cleanly and easily, it is riddled from the outside of the stove with the doors closed.

To burn wood, push the operating tool up and away from you.

When left in this position, air is restricted through the bed of the fire providing a solid base to build up a bed of ash.

Surplus ash can be removed either by gentle riddling or with a shovel.

It might prove beneficial when burning more reactive fuels to leave the grate in a “neutral” position, thus directing some under fire air and some over fire air to the fire bed.



### **Grate Operation & Burning Solid Mineral Fuels**

**To burn solid mineral fuels**, place the operating tool over the riddling spigot and pull it towards you. When left in that position, air is directed under and up through the slots in the firebed, giving the optimum conditions for burning solid fuels.

It is important that the riddling tool is used to remove the ash to ensure airflow through the fire bed and allow the fire to burn over the entire area of the grate. The ashpan should be emptied at least daily and ash should never be allowed to build up over a period of time as this will result in damage to the fire bars. The flat end of the riddling tool can be used to carry the ashpan.



### **Loading The Appliance (Solid Mineral Fuel)**

Solid mineral fuel should be placed in the stove so that there is no more than a 30° incline of the fuel bed from front to back. It should **not** be stacked above the level of the rear firebrick as this may result in damage to the stove.

With a full load of fuel, the stove will need to be refuelled approximately once every 2 hours.

### **Air Controls (Solid Mineral Fuel)**

Solid mineral fuel burns most efficiently with the secondary air control in the closed position. The primary valve lever can then be used to control the burn rate of the stove.

Always de-ash before refuelling and do not let the ash build up to the underside of the grate bars. Solid mineral fuel produces ash, which if allowed to build up will stifle the airflow through the Primary air valve cavity and grate. This will eventually cause the fire to die. With some solid mineral fuels, a residue of burnt fuel or clinker will accumulate on the grate, allow the fire to go out periodically to remove this.

### **IMPORTANT!**

We cannot stress firmly enough how important it is to empty the ashpan regularly. Air passing through the fire bed cools the grate bars. Distortion or burning out the grate bars is nearly always caused by ash being allowed to build up to the underside of the grate.

### **Extended Burning (Solid Mineral Fuel)**

The stove can be banked up for extended burning. When burning solid fuel, empty the ashpan. Open air controls and let the fire burn brightly for a short period. Refuel and close both air controls, the exact setting required will depend on the fuel used and the chimney draw so some practice may be necessary.

To revive the fire, open the air controls until the fire is burning brightly de-ash if necessary and refuel. Set air controls as required.

**Never leave the stove unattended until you are certain that the flames are fully established. Should the fire fail to light correctly** open the door and use a poker to spread the fuel across the bottom of the firebox. Close the door and allow the fuel and stove to cool before attempting to relight the fire.

### **Notes on Woodburning**

With a full load of wood, the stove will need to be refuelled approximately once every hour. Wood can be stacked in the stove, but care must be taken that logs do not touch the baffle. Overloading the stove can cause excess smoke to be emitted. Wood burns most efficiently with the secondary air valve lever in the open position and the primary control closed. Moving the secondary control will control the burn rate of the stove.

Note - primary and secondary air is needed to light the stove, see section entitled 'Lighting the Stove'  
Wood burns most efficiently on a bed of ash and it is therefore only necessary to remove surplus ash from the stove occasionally.

If there is insufficient burning material in the fire bed to light a new fuel charge, excessive smoke emission can occur.

Refuelling must be carried out with a sufficient quantity of glowing embers and ash, so that the new fuel charge will ignite quickly. If there are too few embers, add some kindling to prevent excessive smoke.

Log maximum length: 500mm (19 ¾")

**Ensure your logs are well seasoned with a moisture content of less than 20%**

### **Reduced Combustion**

In order to shut down the stove, close the primary control, then close the secondary air slider by moving the handle all the way to the left. If the controls are left in this position, the fire will be starved of air and will die down.

If you want to revive the fire it is recommended that the primary air control is open first, and then open the secondary air slider.

**Warning!** - The stove will remain **hot** for a considerable time after the fire has been extinguished.

## **Refuelling**

Refuelling must be carried out with a sufficient quantity of glowing embers and ash, so that the new fuel charge will ignite quickly. If there are too few embers, add some kindling to prevent excessive fuel. The air controls should not need adjusting while refuelling.

(When refuelling it is important to have a damper in the open position if you have one.)

## **Recommended Fuels**

Hunter Stoves Group recommend that only wood logs with a moisture content of less than 20% and anthracite or a manufactured briquette smokeless fuel which is suitable for closed door appliances are used on this appliance. Burning wet or unseasoned wood will create excess smoke emissions, tar deposits in the stove and chimney and will not produce a satisfactory heat output.

Only authorised fuels may be used in UK smoke control areas. A list of authorised fuels can be found at <http://uksmokecontrolareas.co.uk/fuels.php>

**WARNING - DO NOT BURN BITUMINOUS COAL, PETRO-COKE, OTHER PETROLEUM BASED FUELS OR TREATED WOOD SUCH AS PALLETS AS THIS WILL INVALIDATE THE PRODUCT WARRANTY. HOUSEHOLD WASTE MUST NOT BE BURNT ON THIS APPLIANCE.**

A list of approved fuels can be found at: -

HETAS Ltd – Telephone 01242 673257 – [http://hetas.co.uk/public/hetas\\_guide.html](http://hetas.co.uk/public/hetas_guide.html)

Solid Fuel Association – Telephone 0800 600 000 – [www.solidfuel.co.uk](http://www.solidfuel.co.uk)

# **Maintenance And Servicing**

## **WARNING!**

NO unauthorised modification of this appliance should be carried out.

## **IMPORTANT!**

In order to ensure continued compliance with current Building Regulations and Local Authority Byelaws, this appliance requires regular maintenance by a competent person. N.B. Refer to the 'Removing Internal Components' section of the installation instructions for details on how to remove each component.

## **Periods Of Prolonged Non-Use**

If the stove is to be left unused for a prolonged period, then it should be given a thorough clean to remove ash and unburned fuel residues. To enable a good flow of air through the appliance to reduce condensation and subsequent damage, leave the air controls fully open. If the appliance has been unused for a long period, such as during the spring and summer months, a competent person should check the chimney for potential obstructions before lighting the stove *i.e. get the chimney swept before the start of the heating season?*

## **Baffle**

This should be removed and cleaned at least once a month to prevent any build-up of soot or fly ash that could lead to blocked flue ways and dangerous fume emission. If the baffle is removed the chimney/flue way can be swept through the appliance.

## **Stove Body**

**Painted Finish** - The stove is finished with a heat resistant paint and this can be cleaned with a dry microfibre cloth or dry soft brush. Do not clean whilst the stove is hot. **At no point should any water or other cleaning products be used on the stove.** The finish can be renovated with Hunter Stoves paint.

## **Glass Panel**

Clean the glass panel when cool with a propriety glass cleaner. Highly abrasive substances should be avoided as these can scratch the glass and make subsequent cleaning more difficult. Wet logs on heated glass, a badly aimed poker or heavy slamming of the doors could crack the glass panels. The glass will not fracture from heat. Should you need to replace a glass panel please ensure you purchase a new Gasket at the same time. Please check periodically that the glass clips and screws have not become loose. They should only be finger tight to allow for the expansion and contraction of the glass.

## **Gaskets**

All gasket used on this appliance are produced from a heat resistant material called Manniglas.

The glass gasket will have to be replaced when a new piece of glass is fitted as the gaskets become brittle after firing the stove.

Over time you may also find that the gasket changes colour. This is due to a reduction in the pigment used in the manufacture of the product and no cause for concern.

## **Firebricks**

In normal use, these can last for many years. It is possible however, to crack them if logs are continually jammed against them or if they are frequently struck with a poker. Check periodically for seriously cracked bricks, which can be replaced with new, available from your dealer or our spares website [www.hunterstoves.co.uk](http://www.hunterstoves.co.uk).

## **Door Catch**

The door catch may require adjustment to maintain the door seal. By slackening the internal locking nut and turning the catch bolt one turn towards the door you will achieve a tighter lock when the door is closed.

## **Rope**

Check the 12mm rope around the door. If rope is becoming detached, use rope glue to reattach it. If the rope is in a poor condition, a replacement rope kit may be ordered from the Hunter Stoves Group spares range.

## **Chimney and Flue ways**

It is important that the chimney, flue ways and any connecting flue pipe are swept regularly. This means at least once a year for smokeless fuels and at least twice a year for wood and other fuels. The baffle will need to be removed from its supports in order to sweep the chimney (see assembly instructions). Only wire-centred sweeps' brushes fitted with a guide wheel should be used. If it is not possible to sweep all parts of the chimney through the appliance, ensure there is adequate access to cleaning doors. If the stove is fitted in place of an open fire, then the chimney should be swept one month after installation to clear any soot falls which may have occurred due to the difference in combustion between the stove and the open fire.

## **Annual Service**

Hunter Stoves Group recommend that this appliance is serviced annually, preferably prior to the start of the heating season, thus avoiding any delay in receiving replacement components, should you need them.

If you feel unable to undertake this task, Hunter Stoves recommend that you contact the installation engineer for advice.

Remove all the internal components:

Riddling Bars, Cam Bar, Catch Bar, Ashpan, Side Plates and Baffle. Clean them with a brush and inspect them for damage.

Sweep the chimney/flue system if necessary.

Clean down the internal surfaces of the appliance using a scraper or wire brush.

Inspect these surfaces for damage/corrosion. If corrosion or damage is found, we advise that you consult with your installer about rectification/repair. Brush out or vacuum the inside of the appliance and re-fit the internal components.

Inspect the Glass and Gasket. Clean the Glass with a non-abrasive cleaner if required. If the Gasket is torn or damaged, we recommend that is replaced to ensure that no products of combustion enters the room when the appliance is used.

**Painted Finish** – Use a dry microfibre cloth or dry soft brush to clean the outer surface and touch up the paint if necessary. Burn the appliance at a low rate, after maintenance, to allow any new seals, paint or glue cure properly. The appliance may emit unpleasant odours during this process, please ensure the room is well ventilated. The paint can be ordered through our website [www.hunterstoves.co.uk](http://www.hunterstoves.co.uk).

## TROUBLESHOOTING

	<b>ISSUE</b>	<b>CAUSE</b>	<b>RESOLUTION</b>
<b>OPERATION</b>	Problem starting the fire and keeping it burning	Low flue draught	Speak to your installer
		Wood with moisture content over 20%	Ensure use of dry seasoned wood with less than 20% moisture content
	Unable to control fire	High flue draught	Speak to your installer
	Short burn time	Wood with moisture content over 20%. Insufficient amount of fuel – refer to page 15 (Notes on Woodburning)	Ensure use of dry seasoned wood with less than 20% moisture content
	Over firing	High flue draught	Speak to your installer
		Air controls left fully open	Close air control to reduce output
	Low heat output	Low flue draught	Speak to your installer with advice on a suitable flue system.
		Wet wood (over 20% moisture content)	Ensure use of dry seasoned wood with less than 20% moisture content
Excessive fuel consumption	High flue draught	Speak to your installer	
	Over dry wood	Do not use constructional timber of pallet wood	
<b>SMOKE PROBLEMS</b>	Smoke and small flames	Wood with moisture content over 20%	Ensure use of dry seasoned wood with less than 20% moisture content
	Intermittent smoke spillage into room when appliance door is opened	Low flue draught	Speak to your installer
		Incorrect additional ventilation air in to the building	Speak to your installer
	Continuous smoke spillage into the room when stove is in use	Blocked flue	Open all doors and windows to ventilate the room. Allow the fire to go out. Check flue for blockage. Do not re-use until the problem has been identified. If in doubt speak to your installer.
Blue/grey smoke from chimney	Wood with moisture content over 20%	Ensure use of dry seasoned wood with less than 20% moisture content	
<b>ADVERSE WEATHER</b>	Windy days causing spillage into the room	Down draught in flue caused by air turbulence due to nearby buildings or trees.	Weather conditions combined with the flue terminal position can have an effect on the stoves performance. Speak to your installer.
	Calm days causing spillage into the room	Over size flue giving poor flue draught	Weather conditions combined with the flue terminal position can have an effect on the stoves performance. Speak to your installer.
	Damp/Rainy days lighting and burning problems	Flue temperature low or rain water inside flue.	Use good quality wood to start and maintain the fire, speak to your installer to fit a rain cowl.
	Wind noise	High flue draught	Speak to your installer.

	ISSUE	CAUSE	RESOLUTION
<b>THE APPLIANCE</b>	Creosote build-up in chimney	Wood with moisture content over 20%	Use dry seasoned wood (less than 20% moisture content). Operate at a high temperature for short periods each time the appliance is used to avoid large build-ups of tars and creosotes.
	Tar coming from flue joints	Appliance operated at continuous low temperatures	Operate at a high temperature for short periods each time the appliance is used to avoid large build-ups of tars and creosotes. See user instructions for correct use of air control
		Using poor quality wood	Use dry seasoned wood (less than 20% moisture content).
	Dirty firebricks/glass	Wood with moisture content over 20%	Use dry seasoned wood (less than 20% moisture content).
	Glass blackening	Using poor quality wood	Use dry seasoned wood (less than 20% moisture content).
		Low flue draught	Speak to your installer.
		Incorrect use of air control	See user instructions for correct use of air control
Appliance operated at low temperatures continuously		Operate at high output for short periods. See instructions for correct use of air control.	

<b>FLUES</b>	<p>Flue systems have two main functions:</p> <ol style="list-style-type: none"> <li>1) To remove the smoke, fumes and combustion gasses from the building safely and efficiently</li> <li>2) To provide a sufficient amount of flue draught (suction) in the appliance to ensure the fire keeps burning correctly.</li> </ol> <p>The flue draught is caused by rising hot gases when the appliance is burning.</p> <p><b>If any flue issues persist then speak to your installer before continuing to use the stove.</b></p>
--------------	--

### Serial Number

This number is required when making warranty claims. It is found on the appliance data plate. The data plate is found on the rear of the stove hanging from a small piece of chain.

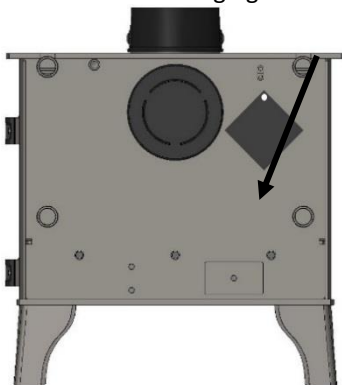

## OPTIONAL EXTRAS

These can be purchased through our website [www.hunterstoves.co.uk](http://www.hunterstoves.co.uk).

PRODUCT	CODE
Glass Cleaner (150mm Aerosol)	SCPGC
Fire Cement (500gm)	SCPFC500
Rope Glue (25ml)	SCPGLUE25ML
Gauntlet Gloves (Pair)	GGLOVE-HSG
Touch up Paint with Brush (236ml)	SCPPB
Spray Paint (400ml)	40.011400HSG
Flue Damper - 6"	HHR99988
Flue Gather Kit (6")	HHR99988K
Operating Tool	HFR07040
<b>MULTIFUEL FRONT EXTENSION</b>	
Consort 9	CNS09035
Consort 15	CNS15030
<b>ROPE SEAL KIT</b>	
Consort 9/15	SCPC915RSK (DOUBLE DOOR) SCPC915SDRSK (SINGLE DOOR)

## Spares Information

### DOOR VIEW BOTH

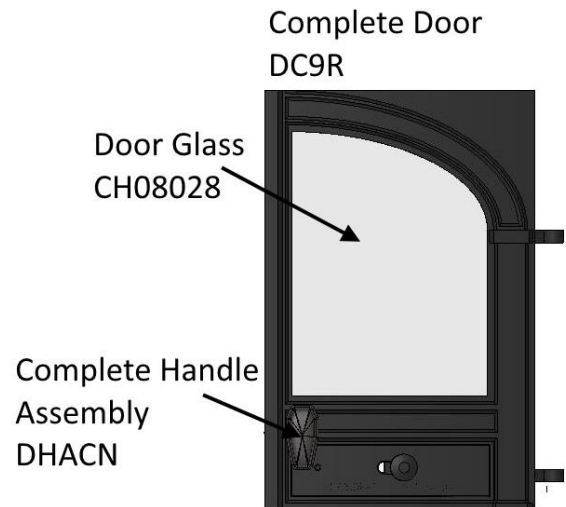
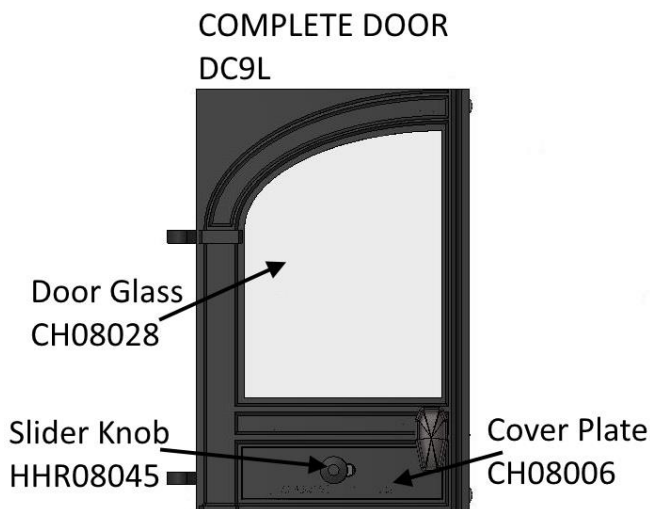

### DOOR REAR VIEW BOTH

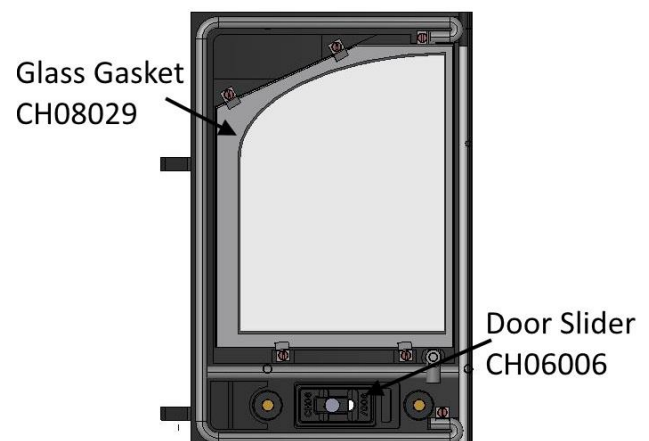
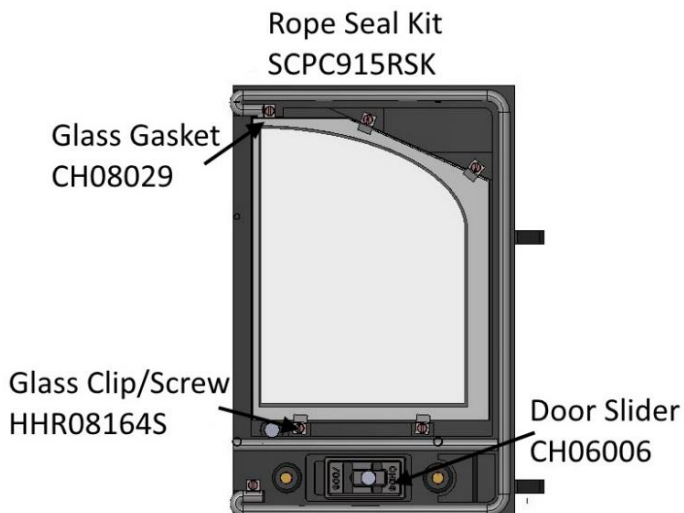

## SINGLE DOOR VIEW BOTH

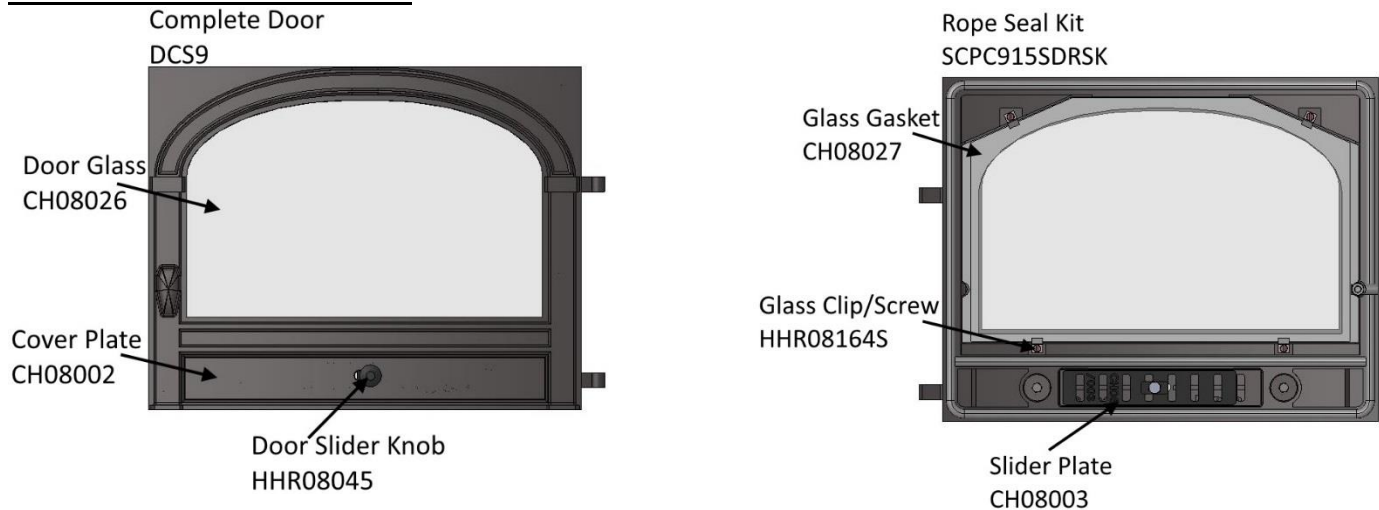

## TOP AIR DEFLECTOR BOTH STOVES (MULTIFUEL & WOOD)

Slider	- CNS09010
Shaft	- HHR14073
Knob	- HHR08045
Deflector	- Single Door – HHR08114
	- Double Door – HHR08026

## BODY ASSEMBLY SPARES - MULTIFUEL (CONSORT 9)

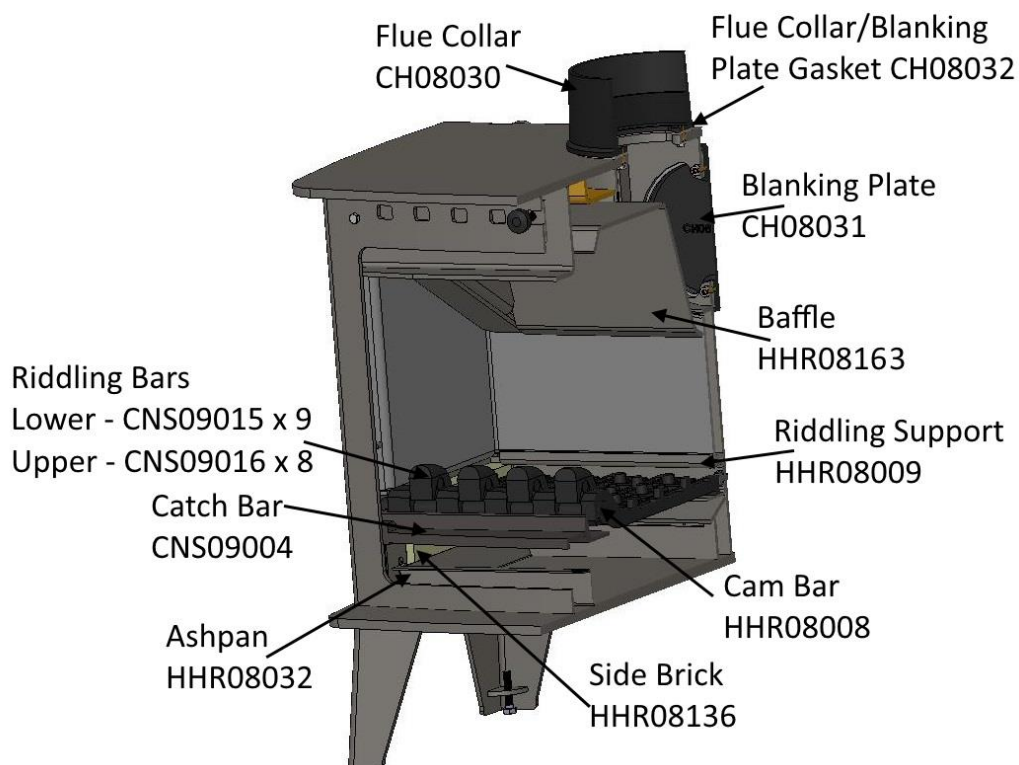

## BODY ASSEMBLY SPARES – WOOD (CONSORT 9)

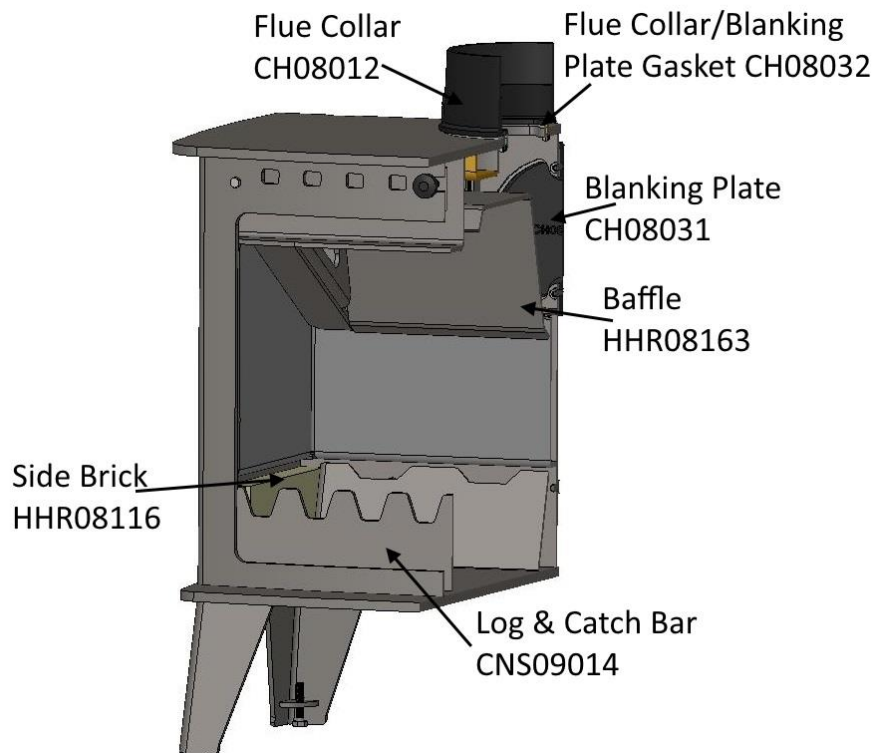

## BODY ASSEMBLY SPARES - MULTIFUEL (CONSORT 15)

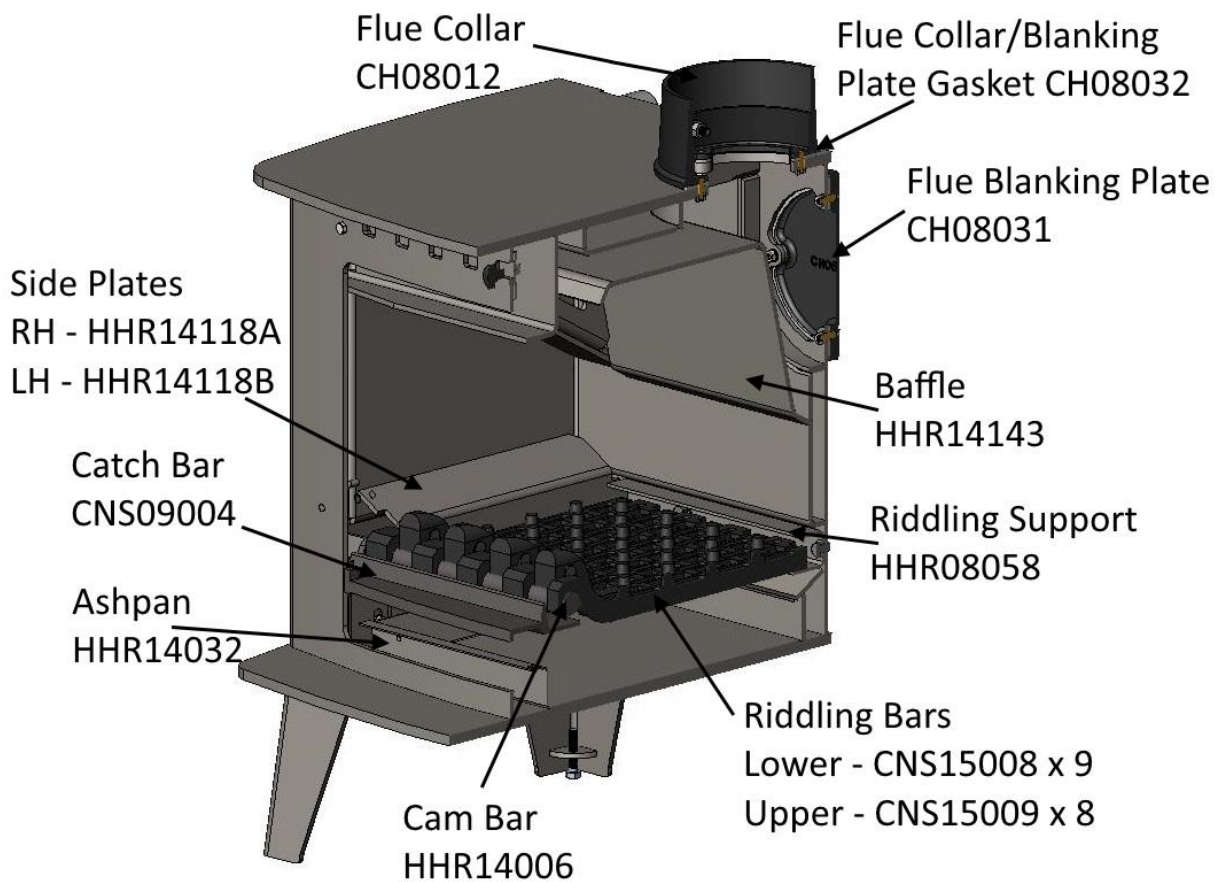



## BODY ASSEMBLY SPARES – WOOD (CONSORT 15)

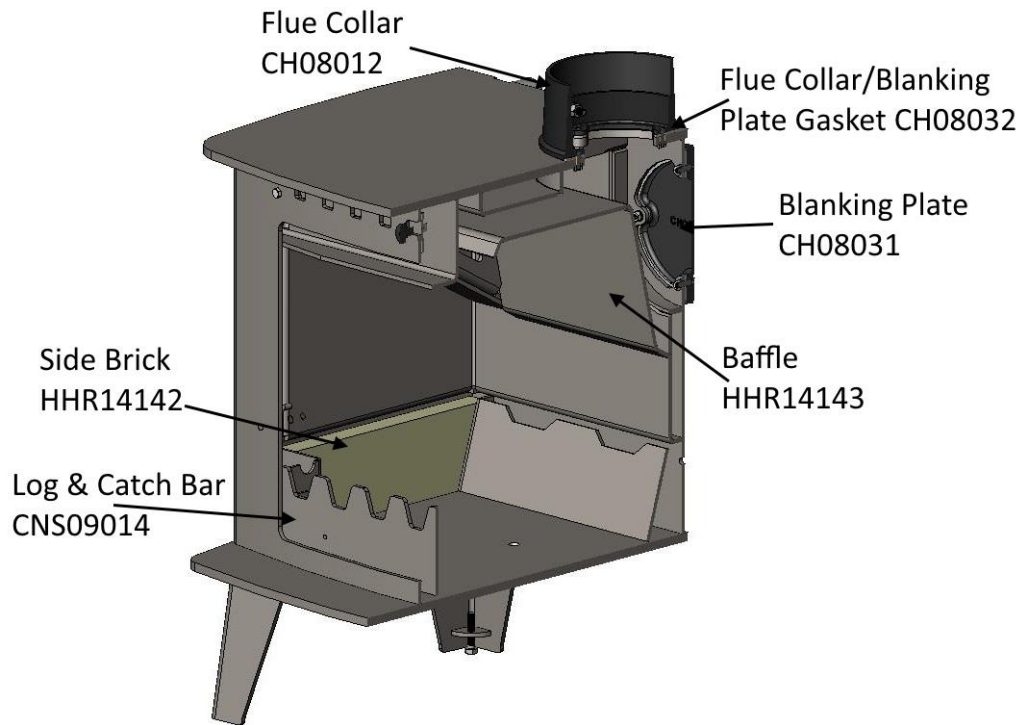

## INSTALLATION & COMMISSIONING CHECKLIST

PURCHASE INFORMATION	
Dealer/Retailer Name	
Address	
Telephone Number	
Email	
Date Purchased	

INSTALLER INFORMATION	
Installer Name	
Address	
Telephone Number	
Email	

APPLIANCE INFORMATION	
Date Installed	
Appliance Stock Code	
Appliance Description	
Serial Number	

COMMISSIONING CHECK (Complete & Sign)		
	YES	NO
Does the chimney/flue system meet the appropriate standard?		
Has the chimney/flue system been swept and passed the soundness test?		
Has this appliance passed the flue draught test?		
Please write down the flue draught reading:		
Has this appliance passed the smoke test?		
Has this appliance passed the spillage test?		
Have you explained how to operate the appliance and explained the controls?		

Signature:	Print Name:
------------	-------------

## SERVICE RECORDS

<b>1<sup>st</sup> Service</b>	
Date of Service	
Date of next Service	
Servicing Company/ Engineer	
Signature	

<b>3<sup>rd</sup> Service</b>	
Date of Service	
Date of next Service	
Servicing Company/ Engineer	
Signature	

<b>5<sup>th</sup> Service</b>	
Date of Service	
Date of next Service	
Servicing Company/ Engineer	
Signature	

<b>7<sup>th</sup> Service</b>	
Date of Service	
Date of next Service	
Servicing Company/ Engineer	
Signature	

<b>9<sup>th</sup> Service</b>	
Date of Service	
Date of next Service	
Servicing Company/ Engineer	
Signature	

<b>2<sup>nd</sup> Service</b>	
Date of Service	
Date of next Service	
Servicing Company/ Engineer	
Signature	

<b>4<sup>th</sup> Service</b>	
Date of Service	
Date of next Service	
Servicing Company/ Engineer	
Signature	

<b>6<sup>th</sup> Service</b>	
Date of Service	
Date of next Service	
Servicing Company/ Engineer	
Signature	

<b>8<sup>th</sup> Service</b>	
Date of Service	
Date of next Service	
Servicing Company/ Engineer	
Signature	

<b>10<sup>th</sup> Service</b>	
Date of Service	
Date of next Service	
Servicing Company/ Engineer	
Signature	

### **2 Year Standard Warranty**

Any appliance bought through the showroom of an authorised Hunter Stoves Group dealership will automatically be covered by our standard 2-year conditional guarantee.

However, this standard 2-year warranty can be extended to a **5 year** or **10-year** conditional warranty dependent on the model type (5 years- Boiler model and Gas models, 10 years- Room heater).

To qualify for this extended warranty option, you need to:

1. Register your purchase online at <https://www.hunterstoves.co.uk/ProductRegistration>
2. Retain your proof of purchase.

### **Warranty Conditions**

For the Standard 2 year or extended 5/10-year warranty to be valid and to remain in force throughout the warranty period the following must have been carried out:

1. The appliance must have been installed by an appropriately qualified engineer (from the Competent Person Scheme/Gas Safe) in accordance with the manufacturer's instructions and in compliance of any relevant national or local building regulations. Please visit the following links for details on the Competent Person Scheme: <https://www.gov.uk/guidance/competent-person-scheme-current-schemes-and-how-schemes-are-authorised> and Gas Safe register: <https://www.gassaferegister.co.uk/>
2. The appliance will need to be registered within two months of purchase and the commissioning and installation documentation completed (these need to be kept by the end user).
3. The appliance must be serviced within 12 months of the installation date for the second year of the standard warranty to be valid, and within every 12-month anniversary thereafter to maintain the validity and coverage of any extended warranty. For this purpose, the installation and user instructions, supplied with the appliance, makes a provision for receipts and annual services to be recorded. This is needed in the event of a claim during the warranty period.
4. Only genuine Hunter Stoves spare parts or consumables can be used in the servicing and maintenance of the appliance during any standard or extended warranty period. These can be sourced from your authorised supplier directly or through our website spares portal. [www.hunterstoves.co.uk/spares](http://www.hunterstoves.co.uk/spares).
5. Any problems or issues giving rise to any claim under the standard or extended warranty must be submitted to the authorised Hunter Stoves Group retailer from whom you originally purchased the appliance. Hunter Stoves Group will then offer appropriate support and help through your original authorised supplier to solve any issues.
6. The standard or extended warranty option is not transferable. It is solely for the benefit of the original purchaser of the appliance. For this purpose, please retain the proof of purchase.

### **Warranty Exclusions**

No warranty period is extended to naturally-wearing replaceable consumables and spare parts within the appliance. Such parts include, but are not limited to:

#### **For Solid Fuel Stoves:**

Glass and rope/ceramic seals  
Fire bricks  
Baffles/Throat plates  
Log retainers, grate supports & catch bars  
Grate parts  
Ash-pans  
Clip-in Boilers

#### **For Gas Stoves:**

Gas pilot assemblies  
Thermocouples and Oxy pilots  
Ceramic log & coal 'fuel -effects'  
Batteries

## **Paint and Surface Coverings**

The paint or surface covering of the appliance will be covered (for 2 years after installation) provided the warranty conditions are met. However, damage due to the following events will not be covered:

1. Damage to the paint surface caused by the appliance being stored in a damp and cold environment is not covered under warranty. Please be aware that any moisture within the room where the stove is installed e.g. through clothes drying, can be a cause of paint issues.
2. In the course of the initial firings of the appliance the paint or enamel surface may change colour. This is normal and as such is therefore not covered under warranty.
3. Damaged caused by over firing, resulting in cracking, bubbling or discolouration to the paint or enamelled surface finish is not covered under warranty.

## **Warranty Limitations**

1. Damage to the appliance due to specific local conditions caused by draft or chimney defects.
2. Damage resulting from installation and use where installation is not in accordance with the manufacturer's instructions or local building and/or safety regulations.
3. Damage or premature wear caused by burning inappropriate fuels such as Bituminous coal, "Petro-Coke" or any other Petroleum based coals. Please visit the HETAS website, [www.hetas.co.uk](http://www.hetas.co.uk), for a full list of approved fuels which are covered by the warranty. Fuels outside of this list are not covered by the warranty.
4. Damage caused by burning material with high creosote content or any other painted/treated timber.
5. Consequential loss to associated non-Hunter Stoves Group products is not covered under the warranty.
6. Consequential loss relating to decorations, soft furnishings or other household assets is not covered under the warranty.
7. Cost associated with the removal and re-installation of an appliance subject to a warranty claim.

Hunter Stoves Group total liability will only extend to the total purchase price paid for the goods in any warranty claim. Hunter Stoves Group reserve the right to replace, repair or refund to value of goods purchased.

**ANY HUNTERS STOVES GROUP PRODUCT PURCHASED VIA AN INTERNET SUPPLIER, OR THROUGH AN UNAUTHORISED STOCKIST WILL ONLY BE SUPPORTED BY THE STATUTORY, 12 MONTH GUARANTEE AND WILL NOT QUALIFY FOR ANY EXTENDED 5 OR 10 YEAR WARRANTY.**

The Hunter Stoves Group extended warranty option does not affect your statutory rights.

This revised standard or extended 5 or 10-year warranty option comes into effect on **1<sup>st</sup> September 2015** and will apply to all appliances sold from that date.

This standard/extended warranty applies to purchases of Hunter Stoves within the United Kingdom and the Republic of Ireland. Purchases in all other countries are subject to the warranty conditions specified by the distributor in those markets.



Hunter Stoves Ltd, 8 Emperor Way, Exeter Business Park, Exeter, Devon, EX1 3QS  
[www.hunterstoves.co.uk](http://www.hunterstoves.co.uk) Email: [info@hunterstoves.co.uk](mailto:info@hunterstoves.co.uk)

## Further Information

For extra guidance on using your stove, please visit our YouTube channel by searching 'Hunter Stoves Group' or see the helpful hints section of our website; [www.hunterstoves.co.uk](http://www.hunterstoves.co.uk).

This appliance is suitable for continuous burning.  
This appliance is not suitable for use in a shared flue.

All genuine Hunter Group spares can be purchased through our website [www.hunterstoves.co.uk/spares](http://www.hunterstoves.co.uk/spares) or through your authorised dealer.

