

Chevin Inset 5 MKII

Model: CVSCHI05FM

Instructions for: Installation/Operation/Maintenance/Serviceing

Approved for use in the United Kingdom and the Republic of Ireland





CONTENTS INDEX:

IMPORTANT INFORMATION.....	3
USER INSTRUCTIONS.....	5
TECHINCAL SPECIFICATION.....	9
PRE INSTALLATION REQUIRMENTS.....	10
INSTALLATION INSTRUCTIONS.....	11
COMMISSIONING AND HANDOVER.....	16
MAINTENANCE & SERVICING.....	17
SPARES & STOVE CARE.....	19
COMMISSIONING & INSTALLATION CHECK LIST.....	22
SERVICE RECORDS.....	23



Parkray Limited,
Emperor Way,
Exeter Business Park,
Exeter,
Devon. EX1 3QS

Email info@hunterstoves.co.uk
Website <http://www.hunterstoves.co.uk>

WARRANTY

Parkray Stoves appliances come with a standard 2 year warranty, however this excludes naturally wearing “consumable” components and the use of un-authorized fuels.

Consumables are deemed to be;

Glass, Seals, Gaskets, Grate Components, Log Retainers, Baffles and the surface finish of the appliance.

The Warranty will only be valid if the appliance is installed by an appropriately qualified engineer in accordance with the manufacturer’s instructions and to the appropriate Building Regulations and/or Local By-Laws and serviced within 12 months of installation.

Parkray Stoves will also support an extended 5 year warranty on external Cast Iron components such as Doors, Flue Collars and Covers.

If this appliance is purchased through an un-authorized stockist or an internet trader Parkray Stoves are only obliged to support the statutory requirements.

This appliance must be regularly serviced and maintained, using only Parkray Stoves approved components for the Warranty to be valid.

IMPORTANT INFORMATION

PLEASE READ THESE INSTRUCTIONS PRIOR TO INSTALLATION AND OPERATION.

KEEP THESE INSTRUCTIONS IN A SAFE PLACE FOR FUTURE REFERENCE AND SERVICING.

THIS APPLIANCE WILL BECOME VERY HOT WHEN USED IN ACCORDANCE WITH THESE INSTRUCTIONS, CLEANBURN STOVES RECOMMEND THAT AN APPROVED GUARD IS USED TO PROTECT THE YOUNG, ELDERLY OR INFIRM FROM HARM.

**THE INSTALLER COMMISSIONING SHEET CAN BE FOUND ON THE BACK COVER.
PLEASE ENSURE THAT IT IS COMPLETED PRIOR TO USE.**

GENERAL GUIDANCE

This Appliance has been certified for use in the countries stated on the cover. Installation in other countries will require translated instructions and may also require modification to comply with local regulations.

It is important that your stove is correctly installed and operated as Parkray Stoves cannot accept responsibility for any fault arising through incorrect installation, use, maintenance or servicing.

These instructions cover the basic principles to ensure satisfactory installation of the stove, although detail may need slight modification to suit particular local site conditions.

The installation must comply with current Building Regulations, National and European Standards, Local Authority Byelaws and other specifications or regulations as they affect the installation of the appliance.

The Building Regulations requirements may also be met by adopting the relevant recommendations in the current issues of British Standards BS 8303 and BS EN 15287-1.

Only use approved fuels on this appliance. Information about this can be found on Page 7.

This is a Domestic Appliance and must only be used in accordance with these instructions.

Do not place articles that are affected by high temperatures on, or near, this appliance. Do not place furniture or other items within 1 metre of the front of this appliance. See the note on material clearances on page 13.

Extractor Fans and/or Cooker Hoods must not be installed in the same space or room as this can cause the appliance to emit fumes into the room.

Do not obstruct the ventilation required for the safe use of this appliance.

COMPETENT PERSONS SCHEME

Parkray Stoves recommend that this stove is installed by a member of an accredited competent persons scheme e.g. HETAS.

If the installer is not a member of a competent person's scheme, it is a legal requirement, in the UK, to notify your Local Building Control Officer in advance of any installation work starting.

HEALTH AND SAFETY PRECAUTIONS

Special care must be taken when installing the stove such that the requirements of the Health and Safety at Work Act are met.

HANDLING

This appliance is very heavy. Adequate facilities must be available for loading, unloading and site handling.

FIRE CEMENT

Some types of fire cement are caustic and should not be allowed to come into contact with the skin. In case of contact, wash immediately with plenty of water.

ASBESTOS

This Stove contains no asbestos. If there is a possibility of disturbing any asbestos in the course of installation then please seek specialist guidance and use appropriate protective equipment.

METAL PARTS

When installing or servicing this stove, care should be taken to avoid the possibility of personal injury.

MODIFICATION

No unauthorized modification of this appliance should be carried out.

SAFETY

WARNING!

This appliance will be hot when in operation and due care should be taken.

DO NOT FIT AN EXTRACTOR FAN IN THE SAME ROOM AS THIS APPLIANCE.

AEROSOLS

Do not use an aerosol spray on or near the stove when it is alight.

FIREGUARDS

Always use a fireguard in the presence of children, the elderly or the infirm. The fireguard should be manufactured in accordance with BS8423 – Fireguards for use with solid fuel appliances.

DO NOT OVER-FIRE

It is possible to fire the stove beyond its design capacity. This could damage the stove so watch for signs of over-firing. If any part of the stove starts to glow red, the stove is in an over-fire situation and the controls should be adjusted accordingly. Never leave the stove unattended for long periods without first adjusting the controls to a safe setting. Careful air supply control should be exercised at all times.

FUME EMISSION

Properly installed and operated, this appliance will not emit fumes. Occasional fumes from de-ashing

and refueling may occur. Persistent fume emission must not be tolerated.

This appliance should not be operated with the door open.

If fume emission does persist then the following action should be taken immediately;

- Open Doors and windows to ventilate room.
- Let the fire out, or eject and safely dispose of fuel from the appliance.
- Check for flue/chimney blockage and clean if required.
- Do not attempt to relight the fire until the cause has been identified and corrected.
- If necessary seek professional advice.

ADVERSE WEATHER

In a small number of installations, occasional local weather conditions (e.g. wind from a particular direction) may cause downdraught in the flue and the stove to emit fumes. In these circumstances the stove should not be used. A professional flue installer will be able to give advice on solutions to this problem (e.g. anti-downdraught cowl).

CARBON MONOXIDE DETECTOR

Parkray Stoves recommend a Carbon Monoxide Detector that conforms to the latest issue of BS EN 50292 is placed in the same room as the appliance. The installation of such an alarm is not considered as a substitute for regular maintenance or servicing or the appliance and Flue system.

IN THE EVENT OF A CHIMNEY FIRE:

- Raise the alarm
- Call the Fire Brigade
- Close appliance air controls
- Move furniture, ornaments etc. away
- Place a fireguard in front of stove
- Check the chimney breast for signs of excessive heat.

If the wall is becoming excessively hot, move furniture away.

Ensure the Fire Brigade can gain access to your roof space in order to check for fire spread.

USER INSTRUCTIONS

Please Read the 'General Guidance' Section at the start of these instructions before operating your stove for the first time.

Allow sufficient clearance between the stove and pictures, plasma screen televisions or ornaments etc., as these could be damaged and could potentially create a fire hazard (For more information read the 'Material Clearance' section of these installation instructions).

WARNING – This appliance will be hot when in operation and due care should be taken. The supplied operating tool may be used to open the door and operate the air controls.

PLEASE NOTE

Your Building Insurance Company may require you to inform you inform them of this new installation and that the work has been carried out correctly. Please check your policy to ensure that it is still valid when this installation is complete.

USING THE APPLIANCE FOR THE FIRST TIME

We recommend that the appliance is left for 24 hours after installation to allow the fire cement, fixing glues, etc. to cure.

We also recommend that you have two or three small fires before you operate your stove to its maximum heat output. This is to allow the paint to cure in steadily and to give a long service life of the paint finish.

During this curing in process you may notice an unpleasant smell. It is non-toxic, but for your comfort we would suggest that during this period you leave all doors and windows open.

AIR CONTROLS

This stove has been designed to burn cleaner and more efficiently than a conventional wood burning stove. If used correctly this stove will burn far more efficiently than normal, with the obvious notable feature of CLEAN GLASS.

However, for this product to work properly it must be used correctly. It is essential that the stove has an adequate air supply for combustion and ventilation. The primary and secondary air inlets must be kept clear from obstruction and blockage

PRIMARY AIR

The slider at the bottom of the stove controls the primary air. This provides a conventional air draught to the bed of the fire. The control is open when the slider is fully to the right.

SECONDARY & TERTIARY AIR

Secondary air is controlled via the slider above the doors; it is this "Airwash" that keeps a clean and uninterrupted view of the fire. The control is open when pushed towards the right of the Stove.

Tertiary air is fixed and enters the stove through the holes on the side of the firebox. It aids in good secondary combustion and reduces emissions into the chimney and environment.

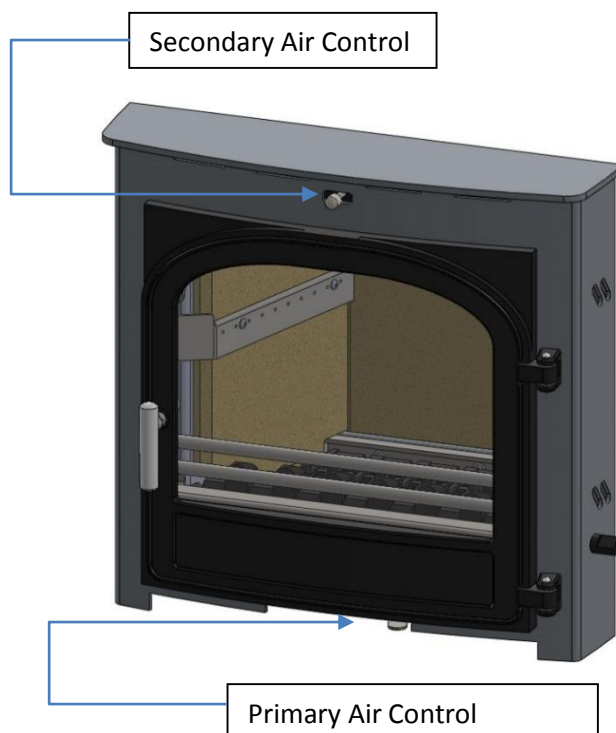

MULTIFUEL GRATE

Your Parkray Stove is fitted with a locomotive type grate. So that de-ashing can be carried out cleanly and easily, it is riddled from the outside of the stove with the doors closed. The grate is designed to burn both wood and solid mineral fuels.

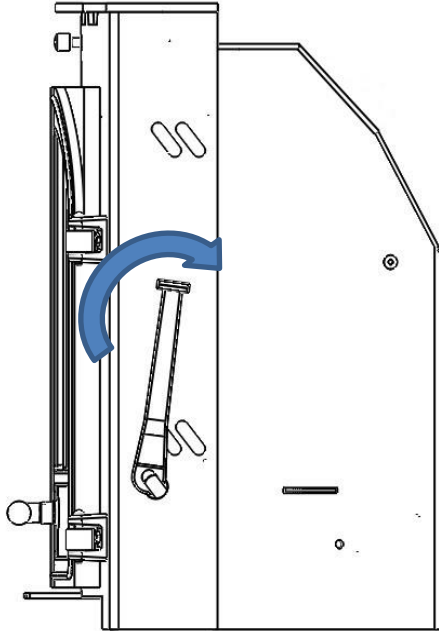

GRATE OPERATION & BURNING WOOD LOGS

Place the operating tool over the riddling spigot and push the operating tool up and away from you. When left in this position, air is restricted through the bed of the fire providing a solid base to build up a bed of ash. Surplus ash can be removed either by gentle riddling or with a shovel.

GRATE OPERATION & BURNING SOLID MINERAL FUELS

Place the operating tool over the riddling spigot and pull it down towards you. When left in that position, air is directed under and up through the slots in the fire bed, giving the optimum conditions for burning solid fuels.

It is important that the riddling tool is used to remove the ash to ensure airflow through the fire bed and allow the fire to burn over the entire area of the grate.

The ashpan should be emptied at least daily and ash should never be allowed to build up over a period of time as this will result in damage to the fire bars. The flat end of the riddling tool can be used to carry the ashpan.

It might prove beneficial, when burning more reactive fuels, to leave the grate in a "neutral" position, thus directing some under fire air and some over fire air to the fire bed.

LIGHTING THE APPLIANCE

First, load the fire with starting fuel, i.e. paper, dry sticks and/or firelighters in the mode chosen, either wood or solid mineral fuel. Light the fire at the base leaving all air controls open. Allow the fuel to reach a steady glow and build the fire up gradually. Once you have a good fire established across the grate bed, further fuel can be added as required.

LOADING THE APPLIANCE (WOOD)

With a full load of wood, the stove will need to be refuelled approximately once every hour and a half.

Wood can be stacked higher in the stove than solid mineral fuel but care must be taken that logs do not touch the baffle.

LOADING THE APPLIANCE (SOLID MINERAL FUEL)

Solid mineral fuel should be placed in the stove so that there is no more than a 30° incline of the fuel bed from front to back. It should **not** be stacked touching the rear edge of the baffle as this may result in damage to the stove.

With a full load of fuel, the stove will need to be refuelled approximately once every 4 hours

AIR CONTROLS (WOOD)

Wood burns most efficiently with the primary air control in the closed position and the secondary air control approximately 60% open. Moving the secondary air control will control the burn rate of the Stove.

The secondary air control should not be completely closed unless the primary air lever is also in the closed position.

Wood burns best on a bed of ash and it is therefore only necessary to remove surplus ash from on top of the grate occasionally. Do not let the ash level under the grate reach above the primary air inlet. If allowed to build-up, ash will stifle the airflow through the grate.

Burn only dry, well-seasoned wood, which should have been cut, split and stacked for at least 12 months, with free air movement around the sides of the stack to enable it to dry out. Burning wet or unseasoned wood will create tar deposits in the stove and chimney and will not produce a satisfactory heat output.

AIR CONTROLS (SOLID MINERAL FUEL)

Solid mineral fuel burns most efficiently with the secondary air control in the closed position. Always

de-ash before refuelling and do not let the ash level reach the underside of the grate bars.

Solid mineral fuel produces ash, which if allowed to build-up will stifle the airflow through the Primary air inlets and grate. This will eventually cause the fire to die.

With some solid mineral fuels a residue of burnt fuel or clinker will accumulate on the grate, allow the fire to go out periodically to remove this.

IMPORTANT!

We cannot stress firmly enough how important it is to empty the ashpan regularly. Air passing through the fire bed cools the grate bars. Distortion or burning out the grate bars is nearly always caused by ash being allowed to build up to the underside of the grate.

EXTENDED BURNING (SOLID MINERAL FUEL)

The stove can be banked up for extended burning. When burning solid fuel, empty the ashpan. Open air controls and let the fire burn brightly for a short period. Refuel and close both air controls, the exact setting required will depend on the fuel used and the chimney draw so some practice may be necessary. To revive the fire, open the air controls until the fire is burning brightly de-ash if necessary and refuel. Set air controls as required.

REDUCED COMBUSTION

In order to reduce the combustion of the fire to a minimum, close the primary air controls, then close the secondary air slider by moving the handle all the way to the left. If the controls are left in this position, the fire will receive the minimum of air and will die down. If you want to revive the fire it is recommended that the Primary Air control is open first and then open the secondary air slider.

REFUELING

Add the new fuel to the fire and open both air controls fully to allow flames to establish on the new fuel. Once the fire is established and the logs are blackened, set the primary air control to its closed position and adjust the secondary air to give the desired heat output.

Never leave the stove unattended until you are certain that the flames are fully established.

Avoid refuelling on to a low fire bed as this may cause excessive smoke emission. Ensure there are sufficient embers to ignite the new fuel rapidly. Alternatively add some more kindling before

adding larger pieces of firewood. Do not add firewood above the level of the tertiary air inlets on the sides of the stove. Exceeding this amount can result in the production of excessive smoke.

EXTINGUISHING THE FIRE

In order to reduce the rate of combustion, close the primary air lever and then the secondary air lever by moving the handles all the way to the left. If the controls are left in this position, the fire will be starved of air and go out. If you want to revive the fire it is recommended that the primary air control is opened first, then open the secondary air slider.

WARNING!

The stove will remain **hot** for a considerable time after the fire has been extinguished

RECOMMENDED SOLID MINERAL FUELS

Only authorised fuels may be used in UK smoke control areas.

A list of authorised fuels can be found at:

<http://uksmokecontrolareas.co.uk/fuels.php>

This stove has been independently tested and approved to burn manufactured and natural smokeless fuels that appear in the HETAS guide.

A current list of approved fuels can be found at:

http://hetas.co.uk/public/hetas_guide.html

Approval does not cover the use of other fuels either alone or mixed with the suitable fuels listed above, nor does it cover instructions for the use of other fuels.

WARNING!

Petroleum coke fuels or household waste must not be burnt on this appliance. Do not use treated timber.

Should any difficulties arise over fuel quality or suitability, consult your local approved coal merchant or:

HETAS Ltd.

Telephone 01684 278170 – www.hetas.co.uk

Solid Fuel Association

Telephone 0845 601 4406 – www.solidfuel.co.uk

WOOD LOGS

Ensure your logs are well seasoned with a moisture content of less than 20%.

Maximum
Length:
235mm (9 3/4")



CLEAN AIR ACT 1993 AND SMOKE CONTROL AREAS

Under the Clean Air Act 1993 local authorities may declare the whole or part of the district of the authority to be a smoke control area. It is an offence to emit smoke from a chimney of a building, from a furnace or from any fixed boiler if located in a designated smoke control area. It is also an offence to acquire an "unauthorised fuel" for use within a smoke control area unless it is used in an "exempt" appliance ("exempted" from the controls which generally apply in the smoke control area).

The Secretary of State for Environment, Food and Rural Affairs has powers under the Act to authorise smokeless fuels or exempt appliances for use in smoke control areas in England. In Scotland and Wales this power rests with Ministers in the devolved administrations for those countries. Separate legislation, the Clean Air (Northern Ireland) Order 1981, applies in Northern Ireland. Therefore it is a requirement that fuels burnt or obtained for use in smoke control areas have been "authorised" in Regulations and that appliances used to burn solid fuel in those areas (other than "authorised" fuels) have been exempted by an Order made and signed by the Secretary of State or Minister in the devolved administrations.



Further information on the requirements of the Clean Air Act can be found here:

<http://smokecontrol.defra.gov.uk/>

Your local authority is responsible for implementing the Clean Air Act 1993 including designation and supervision of smoke control areas and you can contact them for details of Clean Air Act requirements.

The Chevin Inset 5 has been recommended as suitable for use in Smoke Control Areas when burning wood logs.

TECHNICAL SPECIFICATION: Chevin Inset 5 MKII

		CHEVIN INSET 5 MKII Parkray Stoves, Emperor Way, Exeter Business Park, Exeter, Devon. EX1 3QS
BS/EN 13229		UKAS# 0692
Stove Mass: 100 kg		
NOMINAL OUTPUT: 4.9 KW		
CO Emission at 13% O ₂ : 0.19%		
Mean Flue Gas Temperature: 292°C		
EFFICIENCY: 77.1%		
Flue Gas Mass Flow: 4.3 g/s		
Minimum clearance to combustible material		
Top of Fire Surround:		200mm
Side of Fire Surround:		150mm
Side Wall:		300mm
This appliance is suitable for intermittent burning		
This appliance is not suitable for use in a shared flue		
Read and follow the operating instructions		
Use only recommended fuels		

This stove has been designed and assembled so that it may be used to burn wood logs in a Smoke Control Area.

Find out if you are in a Smoke Control Area by contacting your Local Authority.

The Chevin Inset 5 has been fitted with a permanent bypass that prevents closure of the secondary air slider. Removal of this will lead to the appliance potentially causing smoke emissions. Without the permanent bypass in place the appliance is not an exempt appliance and so may leave the householder liable for a fine up to £1000.

APPLIANCE DIMENSIONS

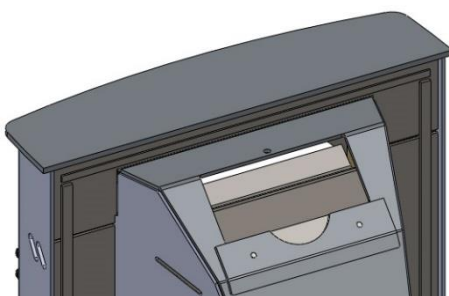

Rear of Stove showing the Flue Infill Plate (Standard Supply Configuration)

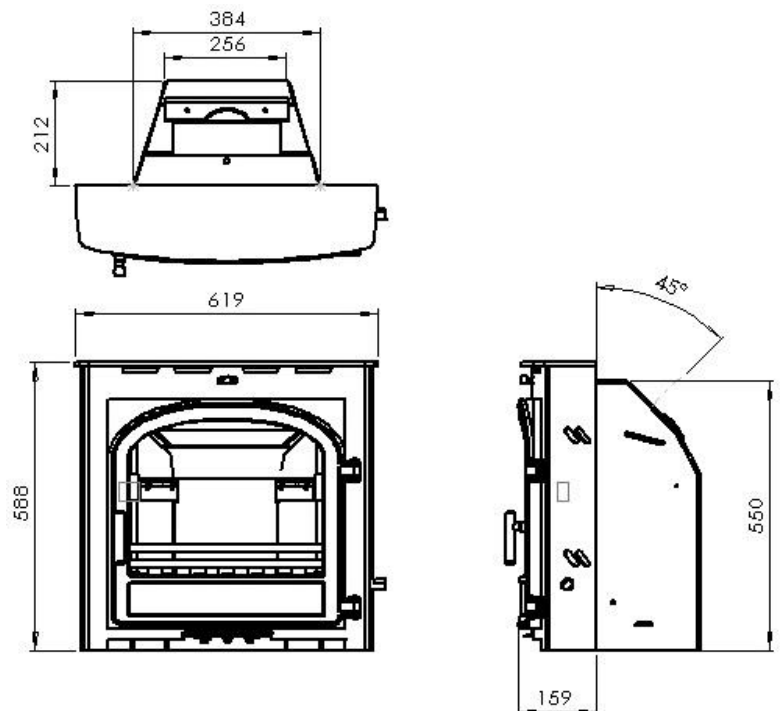

PRE-INSTALLATION REQUIREMENTS

WARNING!

You run the risk of serious health problems if the products of combustion enter the property.

PLEASE CHECK THE FOLLOWING:

Any existing chimney/flue system must be confirmed as suitable for this appliance as defined in Building Regulations Document J.

It must be swept and inspected, by a competent person (see notes), to confirm that is structurally sound and free from cracks and obstructions.

The diameter of the Flue should not be less than $\varnothing 125\text{mm}$ and not more than $\varnothing 230\text{mm}$. Do not connect to systems that have large voids or spaces. If any of these requirements are not met, the chimney should be lined by a suitable method.

If the chimney is suspected of previously serving an open fire it must be swept again, within a month of regular use, to clear any soot that may have been dislodged due to the variation in combustion levels and higher flue gas temperature levels.

The chimney/flue system exit must comply with Building Regulations Document J

The minimum height of the chimney/flue system must be 4.5 metres from the hearth to the top exit. There must be no horizontal sections and must not have more than 4 bends. These bends must have angles of 45° or less.

Make provision to remove the appliance without affecting the chimney/flue system. Make provision to access the chimney/flue system for cleaning and the removal of debris.

If there is no existing chimney then either a prefabricated block chimney in accordance with Building Regulations Approved Document J, or a twin-walled insulated stainless steel flue to BS4543 can be used. These chimneys must be fitted in accordance with the manufacturer's instructions and Building Regulations. New masonry and flue block chimneys must meet the requirements of Building Regulations Document J. Any connecting flue pipe systems must also meet these regulations.

Please check the suitability of the fireplace and/or surround for use with this appliance before installing it.

Many Fire Surrounds are only suitable for use with gas and electric fires and therefore may not be suitable for this Solid Fuel Appliance. Please check your Fire Surround.

Fire Surround Back Panels suitable for solid fuel are usually in three sections and slatted.

This product is designed to fit into a standard 16 inch fire back.

An optional Flue Adaptor (for $\varnothing 125\text{mm}$ flexible liners) is supplied with this Appliance. (Note! Remove bolt-in Flue Infill Plate prior to assembly)

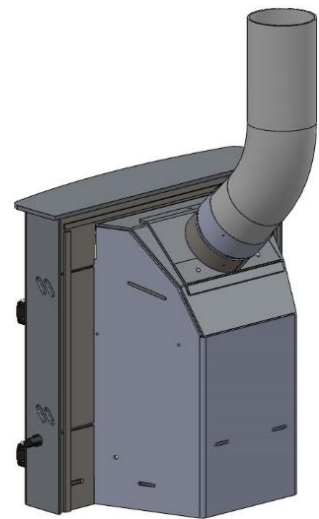

The upper section of the fire back will need to be removed to fit the flue adaptor.

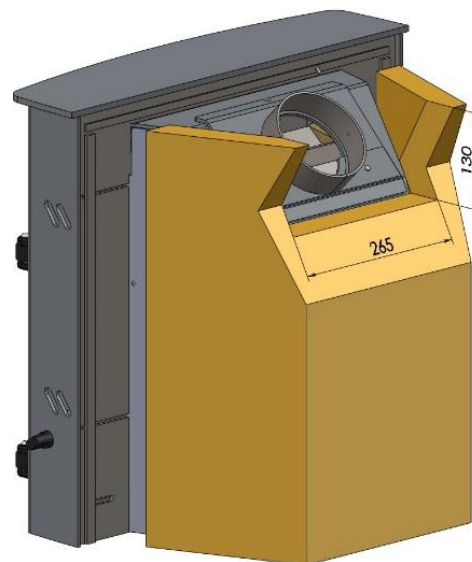

If you have any doubts about the suitability of your chimney, consult your local Dealer/Stockist or Installation Engineer.

Parkray Stoves cannot be held responsible for any fault arising through incorrect use or installation.

FLUE OUTLET POSITIONS (DOCUMENT J):

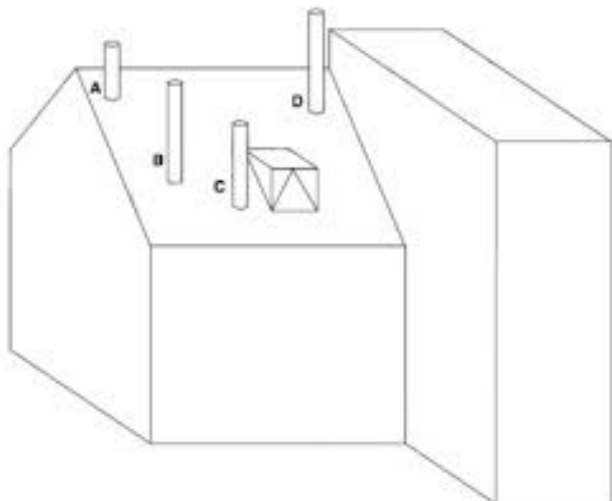

	Position on Roof	Clearances to flue exit
A	At or within 600mm of the ridge	At least 600mm above the ridge
B	Elsewhere on a roof (Pitched or Flat)	At least 2.3 M horizontally from the nearest point on the weather surface and:

		a) At least 1.0 M above the highest point of intersection between the chimney and weather surface; or b) at least as high as the ridge
C	Below (on a pitched roof) or within 2.3 M horizontally to an opening window or dormer	At least 1.0 M above the top of the opening
D	Within 2.3 M of an adjoining or adjacent building, whether or not beyond the boundary	At least 600mm above any part of the adjacent building within 2.3 M

A full copy of Document J can be found here:
http://www.planningportal.gov.uk/uploads/br/BR_PDF_ADJ_2010.pdf

INSTALLATION INSTRUCTIONS

LEGAL REQUIREMENTS

Parkray Stoves requests that before installation and/or use of this appliance that you read these instructions carefully to ensure that all the relevant requirements are fully understood.

These instructions cover the basic principles to ensure satisfactory installation of the stove, although detail may need slight modification to suit particular local site conditions. In all cases the installation must comply with current Building Regulations, Local Authority Byelaws, European and National Standards and other specifications or regulations as they affect the installation of the stove.

It should be noted that the Building Regulations requirements may be met by adopting the relevant recommendations given in British Standards BS 8303, BS 6461 and BS 7566 as an alternative means to achieve an equivalent level of performance to

that obtained following the guidance given in Approved Document J.

Your local Building Control Officer can advise you regarding the interpretation of the Regulations should there be any questions.

This appliance must be installed by a Registered Installer (see Competent Persons Scheme) or approved by your local Building Control Officer.

All works undertaken must be carried out with due care and attention to meet the requirements of the Health & Safety code of practice and any other legislation that may have been introduced since the publication of these instructions.

WARNING!

A faulty installation can cause danger, ill health and even death to the inhabitants and possibly compromise the structure of the building.

COMPETENT PERSONS SCHEME

Members of the following schemes may self-certify the installation of this stove. If the installer is not a member of one of these schemes, your local Building Control Department must approve the installation.

Scheme	Web address	Telephone
APHC (Association of Plumbing and Heating Contractors (Certification) Limited)	www.aphc.co.uk	0121 711 5030
Building Engineering Services Competence Accreditation (BESCA Limited)	www.hvca.org.uk / www.besca.org.uk	0800 652 5533
HETAS Ltd (Heating Equipment Testing and Approval Scheme)	www.hetas.co.uk	01684 278170
NAPIT Registration Ltd	www.napit.org.uk	01623 811483
NICEIC Group Ltd	www.niceic.com	0870 013 0389

FLUE DRAUGHT

A flue draught of minimum 1.2mm to a maximum 2.5mm water gauge is required for satisfactory appliance performance.

The flue draught should be checked under fire at high output with windows and doors closed. To take the reading cover all air intakes (e.g. foil) and put a hole through the covering where the top air intake is for the probe to go through to take the reading.

If it exceeds the recommended maximum, a draught stabiliser must be fitted so that the rate of burning can be controlled and to prevent over firing. If the reading is less than the recommended minimum then the performance of the appliance will be compromised.

CONNECTION TO THE CHIMNEY/FLUE SYSTEM

The gap between the old fireplace and stove flue outlet must be filled in so that there is a smooth streamlined entry into the flue way. It is essential that all connections between the stove and chimney-flue are sealed and made airtight. Both the chimney and any flue pipe must be accessible for cleaning and if ANY parts of the chimney cannot be reached through the stove (with baffle removed), a soot door must be fitted in a suitable position to enable this to be done.

AIR SUPPLY

Where necessary, any air opening must be kept clear of blockage or obstruction. Due consideration should be given to air requirements for any other appliances in the same room or space.

MATERIAL CLEARANCES

Any non-combustible walls within 50mm of this appliance should be at least 200mm thick and should extend 300mm above the top of the appliance and at least 1.2 metres above the hearth. Any walls more than 50mm from the appliance may be reduced to a thickness of 75mm. Ensure the inter-connecting flue pipe also has adequate clearances to combustible materials.

A hearth with a minimum thickness of 125mm should be provided. The hearth should extend to at least 300mm in front of the stove and 150mm at the sides, and should be in accordance with the current building regulations. In all instances the hearth and fireplace recess should be made of non-combustible material.

The appliance shall be installed on a floor with adequate load-bearing capacity. If the existing construction does not meet this prerequisite, suitable measures (e.g. load distributing plate) should be taken to achieve it.

MATERIAL CLEARANCES

Minimum Distances to Combustible Material

Above the stove	200mm
At the side of the stove	150mm
Nearest Side Wall	310mm
In front of the stove	900mm

Note: combustible material refers to any material that will degrade when subjected to heat (e.g. plaster)

FIREPLACE DIMENSIONS

(Fire surround and side wall shown are combustible and all dimensions stated are minimum)

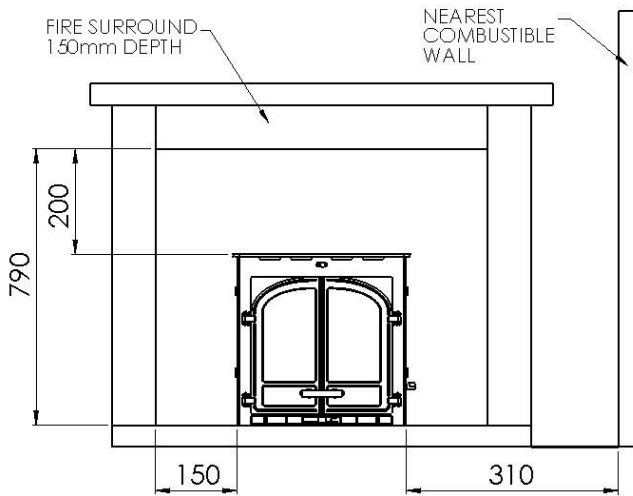

REMOVING INTERNAL COMPONENTS

All internal components must be removed prior to fitting the stove. This will make handling the stove easier; allow access to fixings and the flue outlet; as well as protect the internal components from damage during the installation process.

1. Open the door(s) and remove the ashpan.

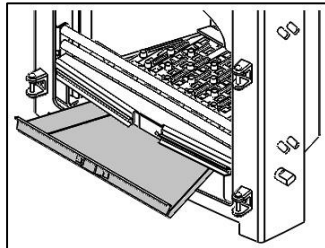

2. Remove the fuel retainer by lifting the right-hand side until it will clear the opening and remove.

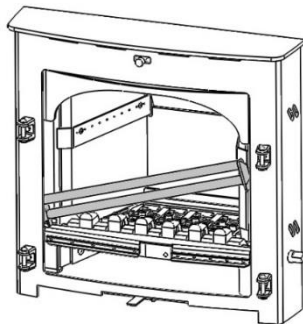

3. Remove the catch bar / front plate by lifting the right-hand side until it will clear the opening and remove.

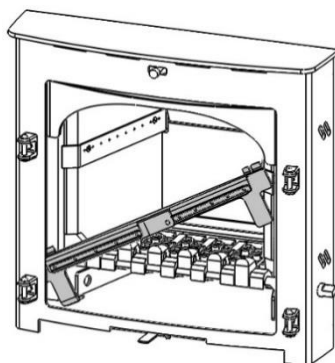

4. Remove the grate bars by lifting them away from the cam bar and pulling forward out of the rear grate support. The singular bars should be removed first, noting their positions (low or high), leaving the two static triangular bars in place.

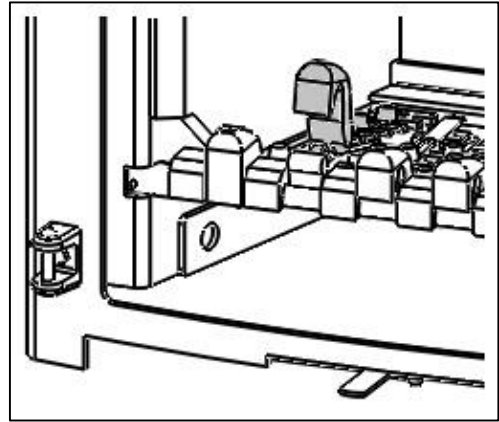

N.B. When re-installing, the side bars need to be installed first, followed by the singular bars. The final two grate bars should be installed at the same time for ease of fit.

5. Lift the front of the Baffle and remove the Upper Side Bricks.

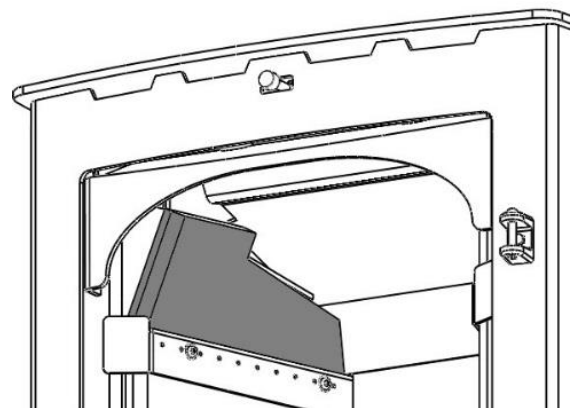
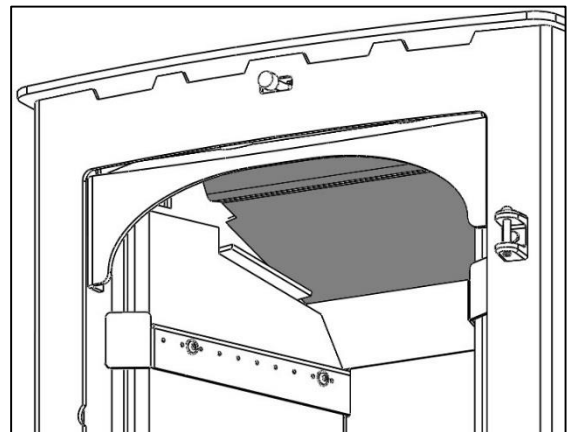

6. Pull the Baffle forward and to the left hand side, allowing the right hand edge of the Baffle to drop down into the stove, and remove. You can now remove the Upper Rear Brick.

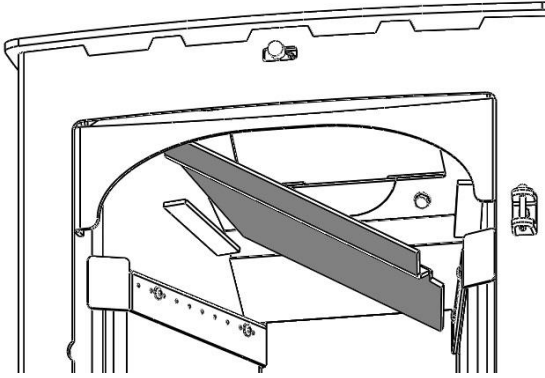

7. Unscrew the 2 M6 Screws and remove the Turbo Bars.

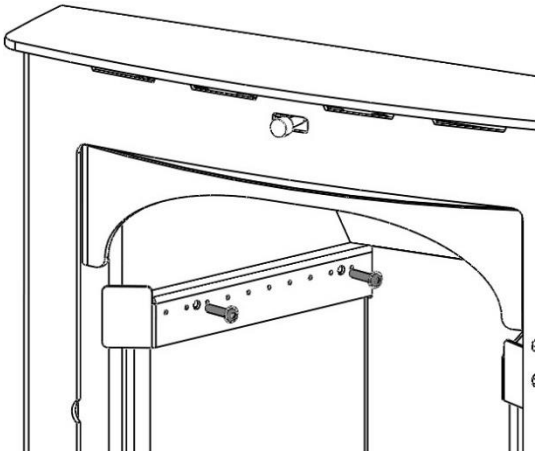

8. Pull the top edge of the Lower Side Bricks forward and remove. You will now be able to remove the Lower Rear Brick.

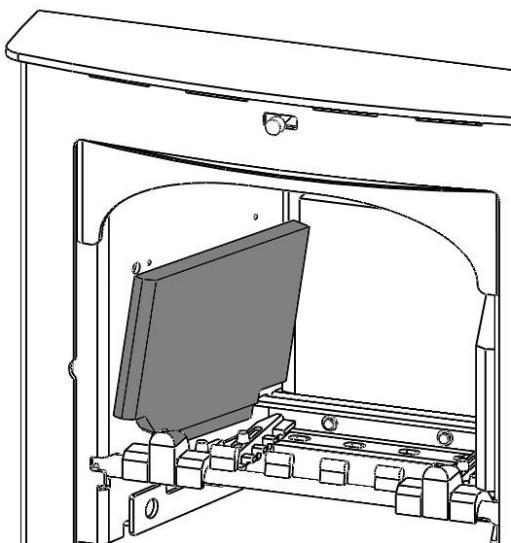

9. You can now remove the Side Riddling Bars.

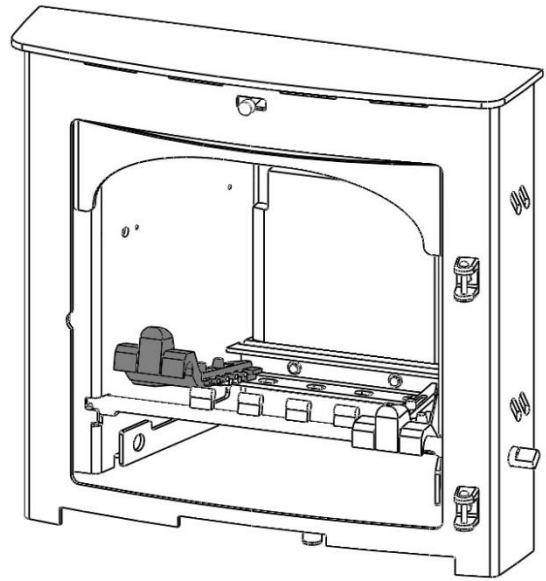

10. Remove the cam bar by firstly sliding it to the right until the left hand end is clear of the hole.

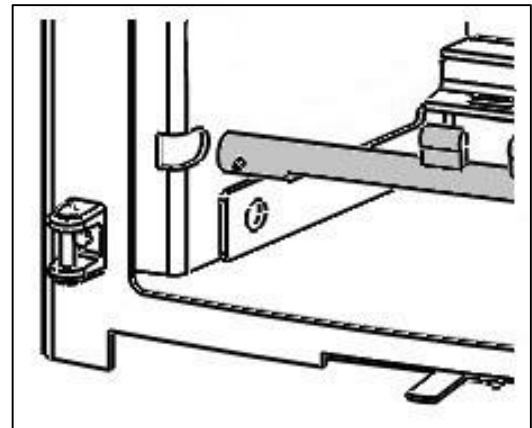

11. Then maneuver the free end into the void in the front left hand side of the Stove.

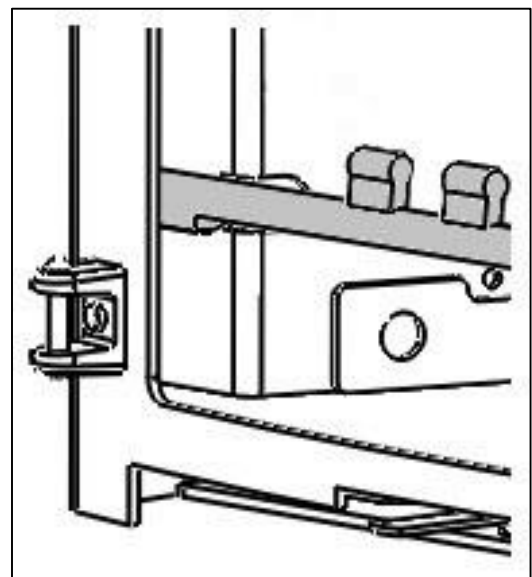

- Slide the cam to the left until the right hand side is clear of the hole, then raise one side and swing out through the door opening.

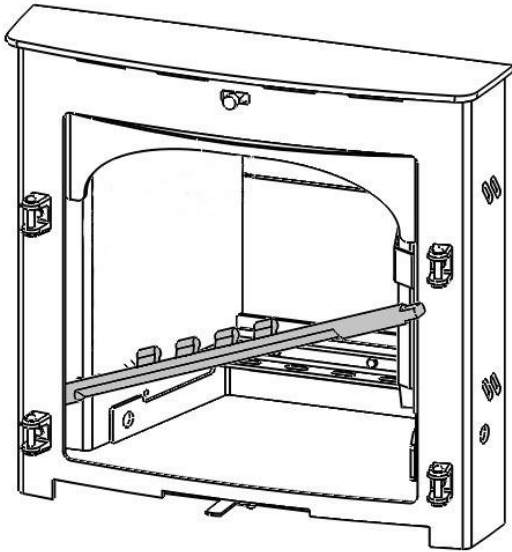

- Remove the ash barrier by sliding out of the stove.

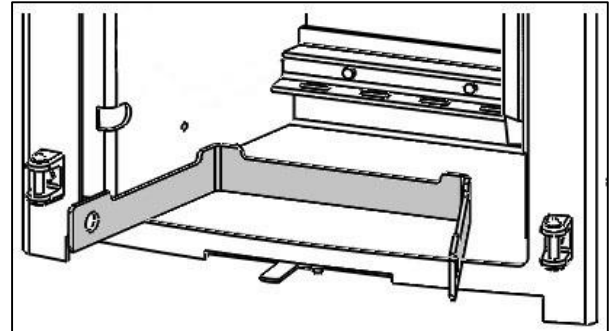

INSTALLING THE STOVE

- Unpack the stove.
- Remove internal components.
- Move the stove into position inside the fireplace opening being careful not to damage the hearth or paintwork on the stove and making sure that the 12mm rope seal is compressed forming a tight seal between the stove and fireplace.
- Drill into the existing fireback through the fixing holes in the body, (see below) using a 6mm drill bit.
- Place the screws provided into the fixing holes and gently tighten until the stove feels secure.
- Fill the fixing holes with fire cement to form an airtight seal.
- Seal the area where the throat meets the flue outlet of the stove with fire cement.
- Refit the internal components.

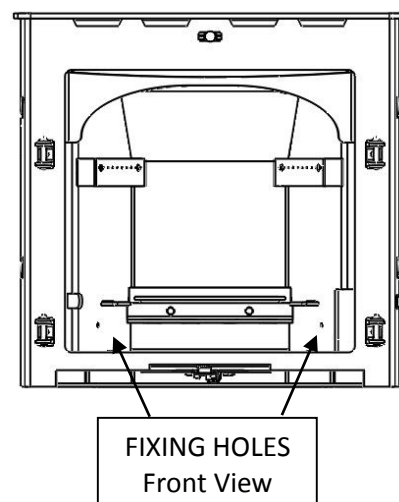
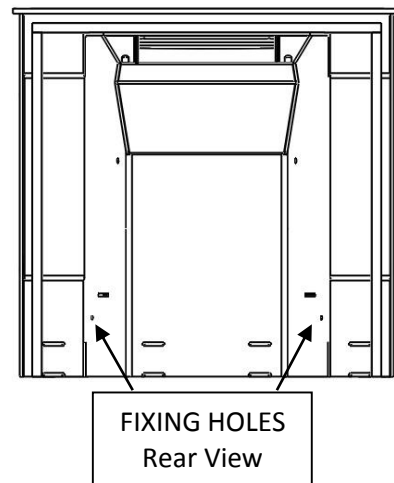

COMMISSIONING AND HANDOVER

APPLIANCE CHECK

Please check that all components are correctly assembled and working correctly.

Ensure the Door Catch mechanism is adjusted correctly and the 12mm Rope Seals around the door are air tight and sealing.

Ensure the Air Controls are working correctly.

Parkray Stoves recommend that you carry out a smoke draw test to check the soundness of the chimney/flue system and seals:

Place a Smoke Pellet in the centre of the Grate, ensure that all of the Air Controls are fully open and close the Door.

The smoke should now be drawn up the chimney and you should be able to see it exit from the chimney/flue terminal.

We recommend that you do this test with all of the windows and doors, to the room where the appliance is fitted, closed.

If there any adjoining room(s) that have an Extractor Fan fitted, open the adjoining door to ensure that the chimney/flue system is not compromised when the fan is operating.

If there is a ceiling fan fitted in the room please operate it and ensure that it does not affect the operation of the chimney/flue system.

If any of these tests fail, please re-check the suitability of the chimney/flue system together with the ventilation.

A small fire can now be lit and allow the appliance to heat up slowly ensuring that no products of combustion enter into the room.

When the appliance has reached working temperature open the Door and carry out a spillage test using a smoke match around the door opening.

If there is excessive spillage please allow the appliance to cool and then re-check the chimney/flue system and ventilation.

Do not run the stove at full output for at least 24 hours.

On completion of the commissioning:

Upon completion, allow a suitable period of time for any fire cement and mortar to dry out. A small fire may then be lit and checked to ensure the smoke and fumes are taken from the stove up the chimney and emitted safely to atmosphere. Do not run the stove at full output for at least 24 hours.

Please instruct the user on the safe operation of this appliance, how the controls work and basic maintenance requirements.

Ensure that the operating instructions and appliance tools are left with the customer and the check lists have been filled out correctly.

Please advise the customer on the correct use of the appliance with the fuels likely to be used on the stove and warn them to use only the recommended fuels for the stove.

Advise the user on what to do should smoke or fumes be emitted from the stove.

The user should be warned to use a fireguard to BS 6539 in the presence of children, aged and/or infirm persons.

Parkray Stoves also recommend that a CO alarm is fitted into the room where the appliance is located.

MAINTENANCE & SERVICING

WARNING!

NO unauthorised modification of this appliance should be carried out.

IMPORTANT!

In order to ensure continued compliance with current Building Regulations and Local Authority Byelaws, this appliance requires regular maintenance by a competent person.

N.B. Refer to the 'Removing Internal Components' section of the installation instructions for details on how to remove each component.

PERIODS OF PROLONGED NON-USE

If the stove is to be left unused for a prolonged period, then it should be given a thorough clean to remove ash and unburned fuel residues. To enable a good flow of air through the appliance to reduce condensation and subsequent damage, leave the air controls fully open. To stop the handle from seizing leave the door ajar. If the appliance has been unused for a long period, such as during the spring and summer months, a competent person should check the chimney for potential obstructions before lighting the stove *i.e. get the chimney swept before the start of the heating season.*

BAFFLE

This should be removed and cleaned at least once a month to prevent any build-up of soot or fly ash that could lead to blocked flue ways and dangerous fume emission. If the baffle is removed the chimney/flue way can be swept through the appliance.

STOVE BODY

The stove is finished with a heat resistant paint and this can be cleaned with a soft brush. Do not clean whilst the stove is hot; wait until it has cooled down. . At no point should any water based or other cleaning products be used on the stove. The finish can be renovated with a propriety high temperature stove paint.

GLASS PANEL(S)

Clean the glass panel when cool with a propriety glass cleaner. Highly abrasive substances should be avoided as these can scratch the glass and make subsequent cleaning more difficult. Wet logs on heated glass, a badly aimed poker or

heavy slamming of the doors could crack the glass panels. The glass will not fracture from heat. Should you need to replace a glass panel please ensure you purchase a new Gasket at the same time. . Please check periodically that the glass clips and screws have not become loose. They should only be finger tight to allow for the expansion and contraction of the glass.

GASKETS

All gasket used on this appliance are produced from a heat resistant material called Manniglas. Over time you may find that the gasket changes colour. This is due to a reduction in the pigment used in the manufacture of the product, and is no cause for concern

FIREBRICKS

In normal use, these can last for many years. It is possible however, to crack them if logs are continually jammed against them or if they are frequently struck with a poker. Check periodically for seriously cracked bricks, which can be replaced with new; available from your dealer or our spares website www.hunterstoves.co.uk.

DOOR CATCH

Should the door catch require adjustment, please follow the procedure below:

Open the Door. Slacken the M6 grub screw, on the underside of the Handle Boss. Turn the inside catch shaft one turn clockwise, this will achieve a tighter lock when the door is closed. Re-tighten the M6 grub screw. Close and test the operation of the Handle mechanism.

ROPE

Check the 12mm rope around the door. If rope is becoming detached, use Parkray Stoves rope glue to reattach it. If the rope is in a poor condition, a replacement rope kit may be ordered from the Parkray Stoves spares range.

CHIMNEY & FLUE WAYS

It is important that the chimney, flue ways and any connecting flue pipe are swept regularly. This means at least once a year for smokeless fuels and at least twice a year for wood and other fuels. The baffle will need to be removed from its supports in order to sweep the chimney.

Only wire-centred sweeps' brushes fitted with a guide wheel should be used. If it is not possible to sweep all parts of the chimney through the appliance, ensure there is adequate access to cleaning doors. If the stove is fitted in place of an open fire, then the chimney should be swept one month after installation to clear any soot falls which may have occurred due to the difference in combustion between the stove and the open fire.

SEASONAL USE

If the appliance has been unused for a long period of time, such as during the spring and summer months, the chimney should be checked for potential obstructions by a competent person before lighting the stove.

DE-ASHING

De-ashing should be carried out on a regular basis to avoid a buildup of ash and ensure sufficient primary air flow. Empty the ashpan regularly to prevent ash reaching the underside of the great bars.

ANNUAL SERVICE

Parkray Stoves recommend that this appliance is serviced annually, preferably prior to the start of the heating season, thus avoiding any delay in receiving replacement components, should you need them. If you feel unable to undertake this task, Parkray Stoves recommend that you contact the installation engineer for advice.

Remove all the internal components:

Riddling Bars, Cam Bar, Catch Bar, Ashpan, Side Plates and Baffle.

Clean them with a wire brush and inspect them for damage.

Sweep the chimney/flue system if necessary.

Clean down the internal surfaces of the appliance using a scraper or wire brush.

Inspect these surfaces for damage/corrosion.

If corrosion or damage is found we advise that you consult with your installer about rectification/repair.

Brush out or vacuum the inside of the appliance and re-fit the internal components.

Inspect the Glass and Gasket. Clean the Glass with a non-abrasive cleaner if required. If the Gasket is torn or damaged we recommend that it is replaced to ensure that no products of combustion enter the room when the appliance is used.

Brush down the outer surface and touch up the paint if necessary.

Burn the appliance at a low rate, after maintenance, to allow any new seals, paint or glue cure properly. The appliance may emit unpleasant odours during this process, please ensure the room is well ventilated.

TROUBLESHOOTING:

Incorrect Flue Draught in your chimney/flue system will cause poor performance of your appliance.

Excessive Flue Draught can cause Poor burning control, excessive fuel consumption and even noise from the Air Controls.

Low Flue Draught can cause difficulty in lighting and running the appliance, poor heat output and smoke entering the room when the Appliance Door is opened.

Poor quality Solid Mineral Fuel and/or damp wood will also affect the performance of your appliance.

Please be aware of the possible warning signs that your appliance is not functioning correctly.

Poor combustion, staining or sooting around the appliance, condensation or dampness on walls or windows in the room where the appliance is fitted, a strange smell when the appliance is lit or water leaking from the appliance.

Please consult with your installer if you are concerned in any way about the performance of this appliance.

TROUBLESHOOTING EXAMPLES:

FIRE WILL NOT BURN

Check that:

1. The air inlet is not obstructed in any way.
2. Chimneys and flue ways are clear.
3. A suitable fuel is being used.
4. There is an adequate air supply into the room.
5. An extractor fan is not fitted in the same room as the stove.
6. Flue draught is above minimum level (see installation instructions).

FIRE BLAZING OUT OF CONTROL

Check that:

1. The doors are tightly closed.
2. The air controls are all in the closed position.
3. A suitable fuel is being used.
4. The glass retaining clips are not loose.
5. The door rope seals are in good condition
6. Flue draught is below maximum level (see installation instructions).

SPARES AND STOVE CARE

Single Door Assembly

Single Door (HCE09008)

Door Handle Assembly
(TDI05ARRT011MB)

Rope Sealing Kit
(SCPCB900SDRSK-REVC)

Single Door Glass (HCE09102)
Single Door Gasket (HCE09101)

Glass Clip (HHR08146)
Glass Clip Screw (FSJM05008SS)

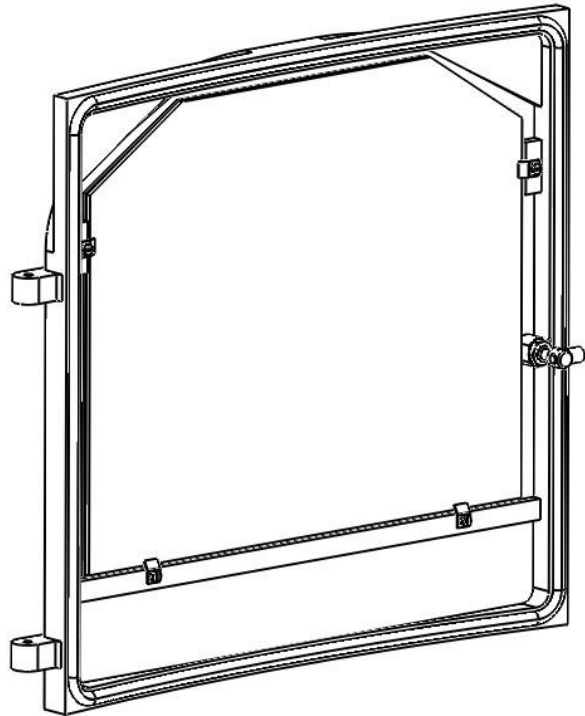
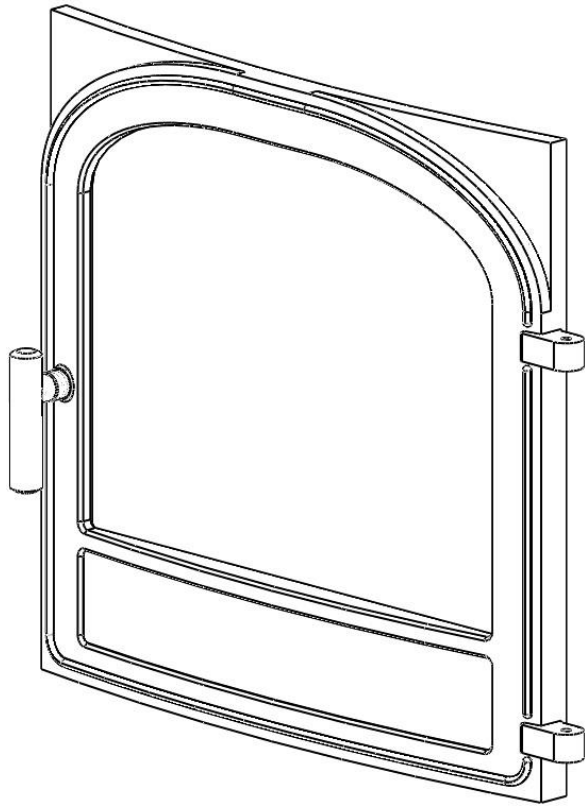

Left Hand Door Assembly

Left Hand Door (TDI05008)

Glass Clip (HHR08046)
Glass Clip Screw (FSJM05008SS)

Double Door Glass (HCE09031)
Double Door Gasket (HCE09030)

Door Handle Assembly
Door Handle Boss (AVI05010MB)
Door Handle, Stainless (AVA08020MB)
Hex. Screw (FSHM08050)

Rope Sealing Kit
(SCPCB900DDRSK)

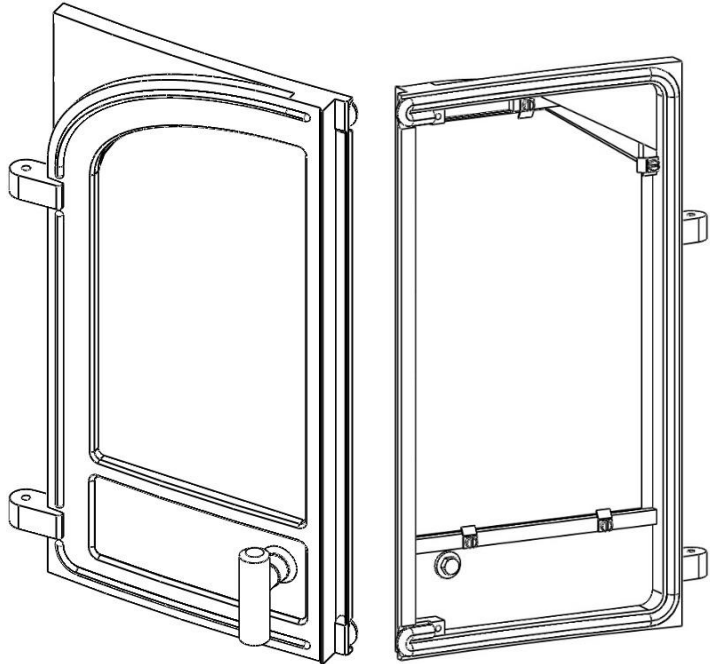

Right Hand Door Assembly

Right Hand Door (HCE09009)

Door Handle Assembly
(TDI05ARRT012MB)

Double Door Glass (HCE09031)
Double Door Gasket (HCE09030)

Glass Clip (HHR08046)
Glass Clip Screw (FSJM05008SS)

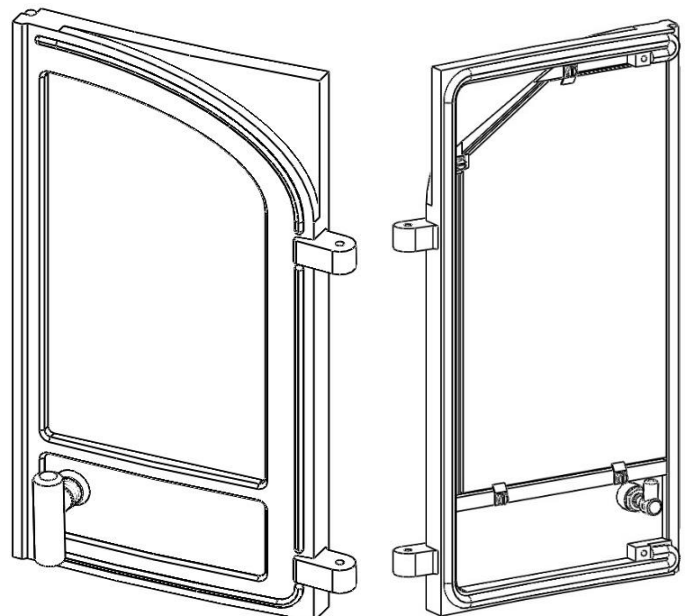

Body Assembly Components

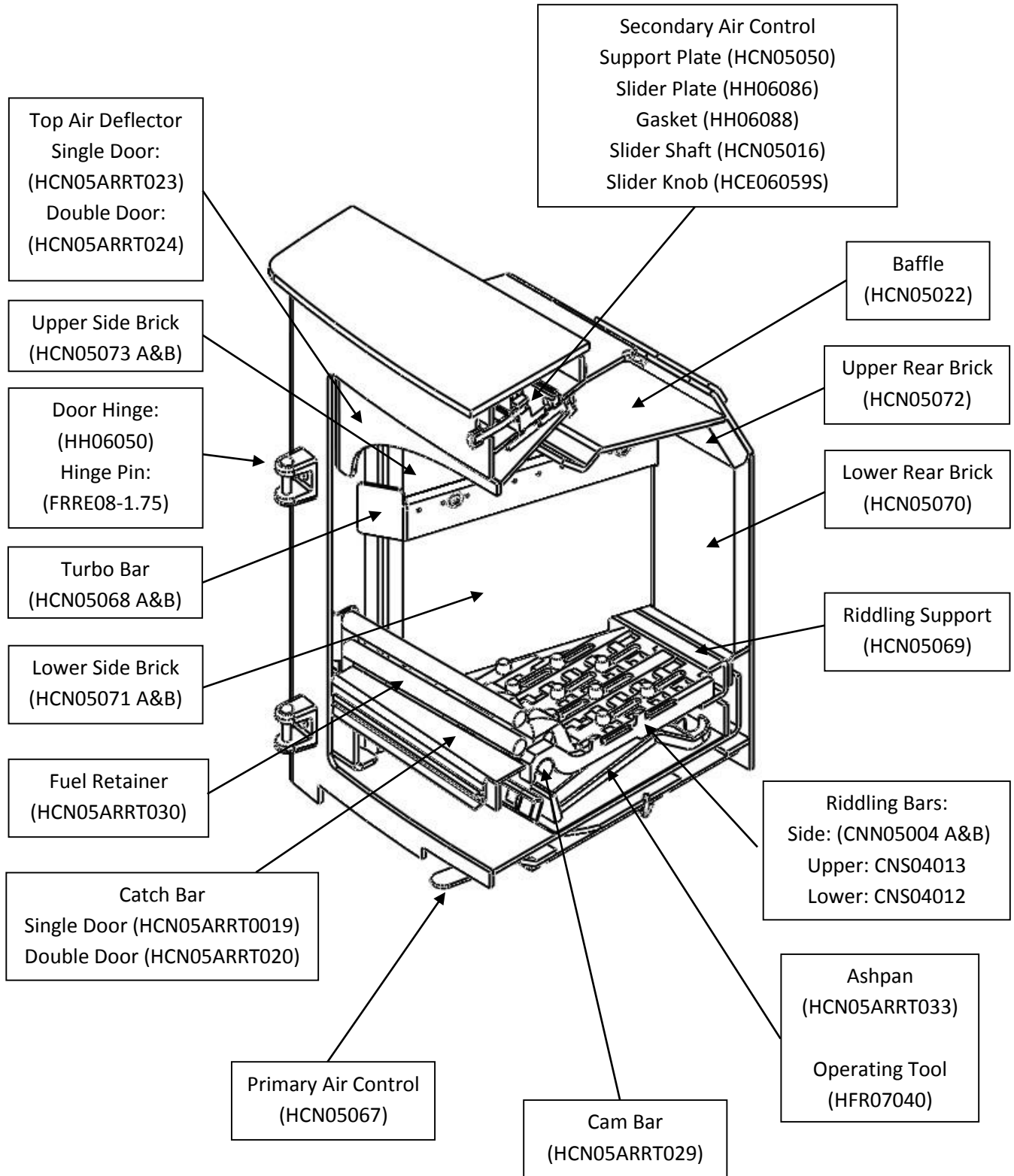

COMMISSIONING & INSTALLATION CHECKLIST

PURCHASE INFORMATION	
Dealer/Retailer Name	
Address	
Telephone Number	
Email	
Date Purchased	

INSTALLER INFORMATION	
Installer Name	
Address	
Telephone Number	
Email	

APPLIANCE INFORMATION	
Date Installed	
Appliance Stock Code	
Appliance Description	
Serial Number	

COMMISSIONING CHECK (Complete & Sign)		
	YES	NO
Does the chimney/flue system meet the appropriate standard?		
Has the chimney/flue system been swept and passed the soundness test?		
Has this appliance passed the flue draught test?		
Please write down the flue draught reading:		
Has this appliance passed the smoke test?		
Has this appliance passed the spillage test?		
Have you explained how to operate the appliance and explained the controls?		

Signature:	Print Name:
------------	-------------

SERVICE RECORDS

1st Service	
Date of Service	
Date of next Service	
Servicing Company/ Engineer	
Signature	

2nd Service	
Date of Service	
Date of next Service	
Servicing Company/ Engineer	
Signature	

3rd Service	
Date of Service	
Date of next Service	
Servicing Company/ Engineer	
Signature	

4th Service	
Date of Service	
Date of next Service	
Servicing Company/ Engineer	
Signature	

5th Service	
Date of Service	
Date of next Service	
Servicing Company/ Engineer	
Signature	

6th Service	
Date of Service	
Date of next Service	
Servicing Company/ Engineer	
Signature	

7th Service	
Date of Service	
Date of next Service	
Servicing Company/ Engineer	
Signature	

8th Service	
Date of Service	
Date of next Service	
Servicing Company/ Engineer	
Signature	

9th Service	
Date of Service	
Date of next Service	
Servicing Company/ Engineer	
Signature	

10th Service	
Date of Service	
Date of next Service	
Servicing Company/ Engineer	
Signature	

