



HERALD

5 & 7

INSTALLATION AND OPERATING INSTRUCTIONS

Please hand these instructions to the stove user when the installation is complete. Leave the system ready for operation and instruct the user in the correct use of the appliance and operation of controls.

HUNTER HERALD 5 & 7

PLEASE READ THESE INSTRUCTIONS CAREFULLY

It is important that your stove is correctly installed, as Hunter Stoves Limited cannot accept responsibility for any fault arising through incorrect installation.

HERALD 5 & 7 STOVE ASSEMBLY

FLUE COLLAR

Place the flue collar on the top or rear outlet as required and secure to the four locating tabs inside the flue outlet using the 6mm nuts & bolts supplied.

BLANKING PLATE

The blanking plate is also fixed to the locating tabs using the two countersunk 6mm bolts & nuts supplied.

THROAT PLATE

The throat plate is supported in the stove via the upper brick-retaining bracket directly below the outlet in the back plate and the baffle support pins on either side.

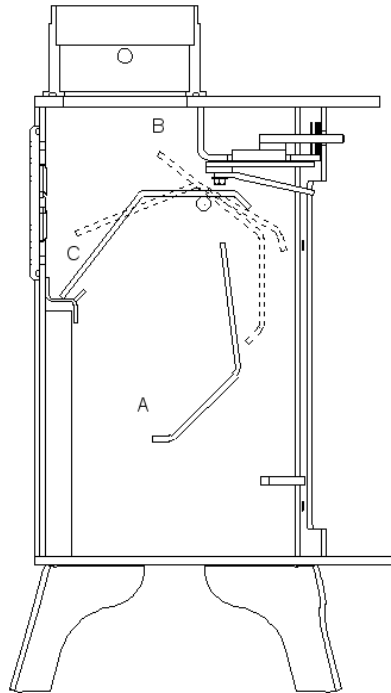

THROAT PLATE FITTING

Place the baffle in the stove as shown by point 'A'. Rotate the baffle up so that the rear edge locates over the two baffle supporting pins, as shown by point 'B'. Then carefully rotate the plate up so that the bottom edge rests on the upper firebrick retaining bar as shown in point 'C'. Removal is the reverse process of fitting.

Diagram showing the fitting of the Throat Plate

FIREBRICKS

MULTIFUEL: -

The rear brick is factory fitted. The side bricks rest on/behind the multifuel side plate which themselves are held in position by the static grate.

WOODBURNER: -

The woodburning version only has rear firebricks, which are held at the back of the firebox by the upper brick-retaining bar.

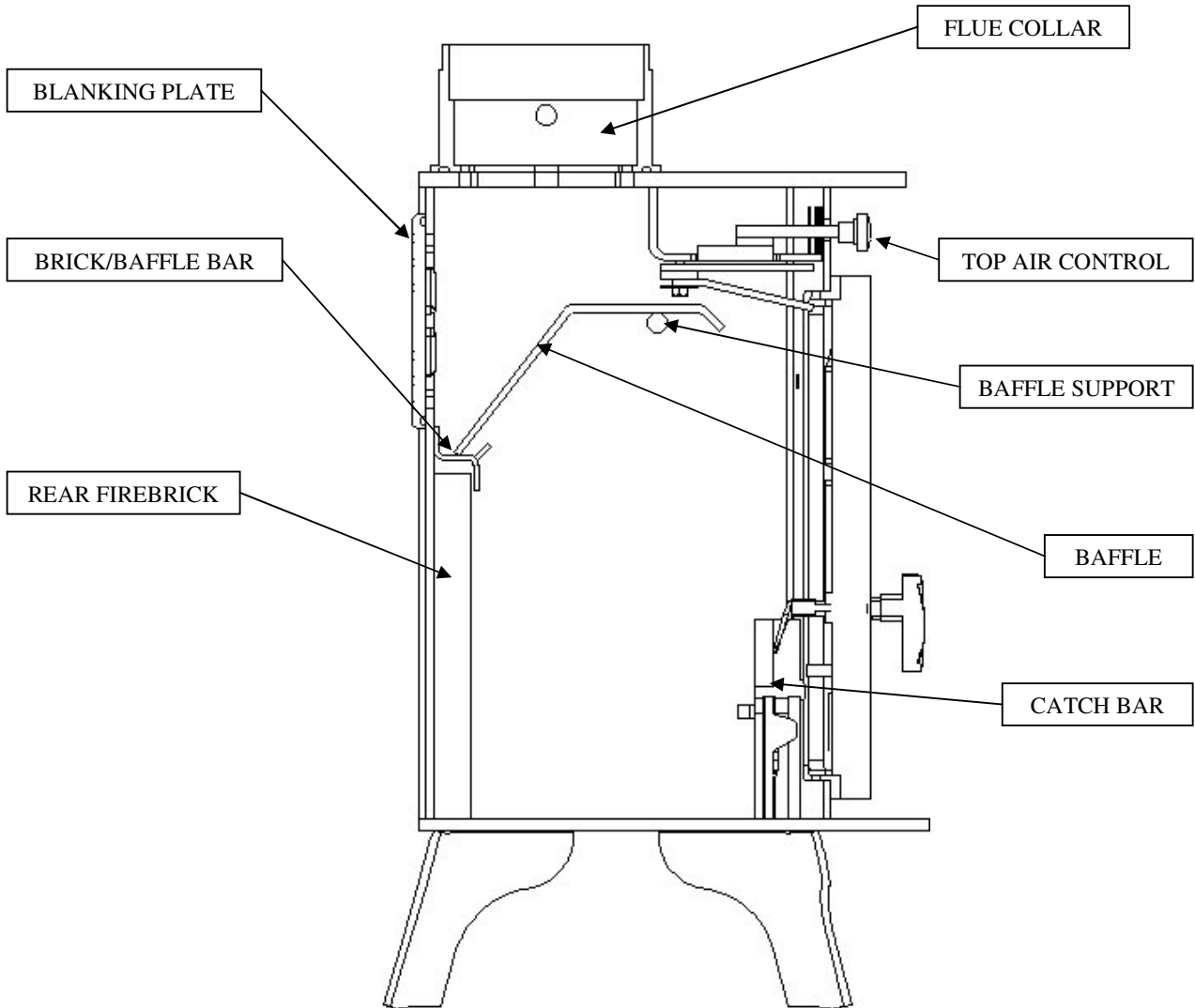

INSTALLATION

Check that the chimney is in good condition, dry, free from cracks and obstructions. **The diameter of the flue should not be less than 150mm and not more than 230mm for Herald 7, 125mm and not more than 230mm for Herald 5.** If any of these requirements are not met, the chimney should be lined by a suitable method.

The chimney height and the position of the chimney terminal should conform to Building Regulations.

A flue draught of minimum 1.5mm to a maximum 2.5mm water gauge is required for satisfactory appliance performance. The flue draught should be checked under fire at high output and if it exceeds the recommended maximum, a draught stabiliser must be fitted so that the rate of burning can be controlled and to prevent overfiring.

If you have any doubts about the suitability of your chimney, consult your dealer/installer.

The chimney must be swept before connection to the stove.

An existing fireplace opening can be bricked up or sealed with a register plate. A short length of flue pipe of a minimum **152mm internal diameter for Herald 7, 125mm internal diameter for Herald 5**, may then be used to connect the stove to the chimney. This flue pipe should be of cast iron, 316 grade stainless steel or vitreous enamelled, nominal thickness 1.2mm. Ensure that the pipe end is no closer than 76mm to the side or rear chimney walls.

Ideally, the old fireplace should be filled in so that there is a smooth streamlined entry into the flueway.

The length of any horizontal run of flue pipe must not exceed the flue outlet diameter on the stove – 125mm.

It is essential that all connections between the stove and chimney-flue are sealed and made airtight.

Both the chimney and flue pipe must be accessible for cleaning and if ALL parts of the chimney cannot be reached through the stove, a soot door must be fitted in a suitable position to enable this to be done.

The stove can be recessed in a suitable sized fireplace but a permanent free air gap must be left around the sides and top to improve maximum heat output and for access to the rear of the stove. There should not be any combustible material within a distance of 900mm from any surface of the stove. In all instances the stove should be positioned on an incombustible hearth. Allow an apron of a least 300mm at the front of the stove and 150mm on either side. The hearth on which the stove is to be placed should not be less than 125mm thick if the floor is made of combustible material, and care should be taken to level the stove.

Upon completion of installation, the appliance should be checked under fire for soundness of joints and seals, and also that all smoke and fumes are taken from the appliance, up the chimney and emitted safely. Care should be taken that all flues, hearths and combustion air supplies are in accordance with the current Building Regulations, Local Authority Bye-Laws, British Standards and Codes of Practice.

OPERATING INSTRUCTIONS

AIR CONTROLS

This stove has been designed to burn cleaner and more efficiently than a conventional wood burning stove. If used correctly this stove will burn far more efficiently than normal with the obvious notable feature CLEAN GLASS.

However, for this product to work properly it must be used correctly.

PRIMARY AIR

Primary air is controlled via the sliders in the bottom of the doors, this provides a conventional air draught to the bed of the fire.

SECONDARY AIR

Secondary air is controlled via the slider above the doors, it is this “airwash” that keeps a clean and uninterrupted view of the fire, also aiding in good secondary combustion of the fuel and reducing emissions into the chimney and environment.

NOTE: The ‘airwash’ is open when the slider knob is pushed to the right.

DAMPER ASSEMBLY (OPTIONAL)

When burning wood, the flue damper assembly may be fitted. When the damper is set in the open position the chimney draws at full draught, increasing the volume of airflow through the stove and flue. Shutting the damper restricts the flow, slowing the rate of burning.

THE FLUE DAMPER SHOULD NOT BE FITTED WHEN BURNING SOLID FUELS

NOTES ON SOLID FUEL BURNING

Always de-ash before refuelling and do not let the ash build up to the underside of the static grate. Solid fuel produces ash, which if allowed to build up will stifle the airflow through the grate and eventually cause the fire to die.

With some solid fuels a residue of burnt fuel or clinker will accumulate on the grate, allow the fire to go out periodically to remove this.

We cannot stress firmly enough how important it is to empty the ashpan regularly. Air passing through the firebed cools the static grate. Distortion or burning out the grate is nearly always caused by ash being allowed to build up to the underside of the grate.

NOTES ON WOODBURNING

Wood burns best on a bed of ash and it is therefore only necessary to remove surplus ash from the stove occasionally.

Burn only dry, well seasoned wood, which should have been cut, split and stacked for at least 18 months, with free air movement around the sides of the stack to enable it to dry out. Burning wet or unseasoned wood will create tar deposits in the stove and chimney and will not produce a satisfactory heat output.

LIGHTING THE STOVE

We recommend that you have two or three small fires before you operate your stove to its maximum heat output. This is to allow the paint to cure in steadily and to give a long service life of the paint finish. During this curing in process you may notice an unpleasant smell. It is non toxic, but for your comfort we would suggest that during this period you leave all doors and windows open.

First, load the fire with starting fuel, i.e. paper, dry sticks and/or firelighters in the mode chosen, either wood or coal.

Light the fire at the base leaving all air controls open. Allow the fuel to reach a steady glow and build the fire up gradually. Once you have a good fire established across the grate bed, further fuel can be added as required.

When your fuel is well alight you can start to restrict the primary air intake. If you are burning only wood, the primary air control can be fully closed. If you are burning solid fuel you will require more primary air.

The stove can be banked up for long periods. When burning solid fuel, empty the ashpan. Open air controls and let the fire burn brightly for a short period. Refuel and close air controls, the exact setting required will depend on the fuel used and the chimney draw so some practice may be necessary. To revive the fire, open air controls until the fire is burning brightly, de-ash if necessary (solid fuel only) and refuel. Set air controls as required.

SOLID FUELS

Anthracite is an approved *natural* smokeless fuel (not *processed*) and therefore can vary greatly in quality and performance. It generally requires excellent air supply and above average fire-bed temperatures to maintain maximum performance and with experience we would suggest that it is used in conjunction with other approved *manufactured* smokeless fuels as per the Solid Fuel Associations' approved list.

Household coal, which is a “smokey” fuel, can also be used but note that different types will give different performances.

PETROLEUM COKE FUELS OR HOUSEHOLD WASTE SHOULD NOT BE BURNT ON THIS APPLIANCE

Should any difficulties arise over fuel quality or suitability, consult your local approved coal merchant or the Solid Fuel Advisory Service – Telephone 0800 600 000.

SAFETY NOTES FOR YOUR GUIDANCE

FIRES CAN BE DANGEROUS – Always use a fireguard in the presence of children, the elderly or the infirm.

DO NOT OVERFIRE – it is possible to fire the stove beyond its design capacity, this could damage the stove, so watch for signs of overfiring – if any part of the stove starts to glow red, the fire is in an overfire situation and the controls should be adjusted accordingly. Never leave the stove unattended for long periods without first adjusting the controls to a safe setting – careful air supply control should be exercised at all times.

WARNING – FUME EMISSION

Properly installed and operated, this appliance will not emit fumes. Occasional fumes from de-ashing and refuelling may occur. Persistent fume emission must not be tolerated.

If fume emission does persist, then the following immediate action should be taken: -

1. Open doors and windows to ventilate room.
2. Let the fire out, or eject and safely dispose of fuel from the appliance.
3. Check for flue chimney blockage and clean if required.
4. Do not attempt to re-light the fire until the cause has been identified.

If necessary, seek professional advice.

DO NOT FIT AN EXTRACTOR FAN IN THE SAME ROOM AS THIS APPLIANCE

HUNTER HERALD 5 & 7

GENERAL MAINTENANCE

THROAT PLATE

This should be removed at least once a month to prevent any build up of soot or fly ash which could lead to blocked flueways and dangerous fume emission.

If the throat plate is removed the chimney/flue way can be swept through the appliance.

STOVE BODY

The stove is finished with a heat resistant paint and this can be cleaned with a soft brush. Do not clean whilst the stove is hot, wait until it has cooled down. The finish can be renovated with a suitable brand of paint.

GLASS PANELS

Clean the glass panels when cool with a proprietary glass cleaner. Highly abrasive substances should be avoided as these can scratch the glass and make subsequent cleaning more difficult. Wet logs on heated glass, a badly aimed poker or heavy slamming of the doors could crack the glass panels. The glass will not fracture from heat.

FIREBRICKS

In normal use, these can last for many years. It is possible however, to crack them if logs are continually jammed against them or if they are frequently struck with a poker.

Check periodically for seriously cracked bricks, which can be replaced with new.

DOORS

Should the doors require adjustment to maintain their seal, each hinge is adjustable. By slackening the locking bolt on the hinge, the doors can be moved in three dimensions aided by the addition or subtraction of shims behind the hinge assembly.

CHIMNEY

Check your chimney each year before starting to use your stove for the winter. Birds may have nested in the chimney or the masonry may have cracked. Both the chimney and flue pipe must be swept at least once a year.

| Description | Herald 5 Order No. | Herald 7 Order No. |
|----------------------------|---------------------------|---------------------------|
| 12mm Sealing Rope | 12SR | 12SR |
| 6mm Sealing Rope | 6SR | 6SR |
| Door - Left Hand | HHR06004 | HHR06004 |
| Door - Right Hand | HHR06005 | HHR06005 |
| Door Knob - Cast | HFR07028C | HFR07028C |
| Door Knob - Brass | HFR07028B | HFR07028B |
| Glass Panel | HH06060 | HH06060 |
| Glass Clip & Screw | HHR08046 | HHR08046 |
| Fan Catch & Nut | HHR08018 | HHR08018 |
| Door Slider | HHR06006 | HHR06006 |
| Door Hinge | HH06050 | HH06050 |
| Air Slider Knob - Steel | HHR08045S | HHR08045S |
| Air Slider Knob - Brass | HHR08045B | HHR08045B |
| Flue Collar | HHR06001 | HHR08023 |
| Blanking Plate | HHR06002 | HHR08024 |
| Multifuel Static Grate | HHW05013 | HHW05013 |
| Multifuel Front Extension | HHW05020 | HHW05020 |
| Ashpan | HHW05015 | HHW05015 |
| Rear Firebrick (Multifuel) | HHW05011 | HHW07011 |
| Side Firebrick (Multifuel) | HHW05016 | HHW05016 |
| Catch Bar | HHW05019 | HHW05019 |
| Woodburner Front Cover | HHW05021 | HHW05021 |
| Operating Tool | HFR07040 | HFR07040 |
| Side Plate (LHS) | HHW05014A | HHW07015A |
| Side Plate (RHS) | HHW05014B | HHW05015B |
| Top Brick Bar | HH06023 | HH06023 |
| Throat Plate | HHW05010 | HHW07010 |

HUNTER HERALD 5 & 7